

CANADA

POST



POSTES

CANADA

Morgan Olson C250 Maintenance Manual



INTRODUCTION

This Maintenance guide contains illustrations and documentation for the Canada Post Package Delivery Vehicle C250 and applies to bill of material JV003609.

How to order Morgan Olson parts from our Canadian Parts Distributor

The first step is to locate the part numbers you would like to order.

Method 1 (Recommended)

Go to our parts web site, WWW.MORGANOLSONPARTS.COM and search your vehicle VIN number to get a list of parts generated directly from your vehicles Bill of Material.

You may filter the list of items further by selecting the category for the location of the parts. IE. Bumper, Hood, Glass, Rear Door, etc.

You may use the search drop down menu to select a different search type: Search By; Description/Part Number, Unit Number or VMRS Number.

Method 2

Use this parts catalog to identify your part numbers.

Method 3

Call our Canadian Parts Distributor, Jim Keay Ford

Primary Contact Ben 1-613-841-4021

Secondary Contact Chris 1-613-841-4021

Please have your VIN number available and the parts specialist will help you identify the parts you need.

DISCLAIMER: The information contained in this publication was correct at the time of going to print. In the interest of continuous improvement, we reserve the right to change specifications, design, or equipment at any time without notice or obligation.

The Morgan Olson C250 is constructed from an altered Ford F150

This document is a supplement to the original equipment Ford F-150 manual. Information contained herein supersedes all applicable text in the F150 manual.

Carryover original F150 equipment (frame, axel, engine, etc) - go to Ford's documentation. Modified F150 equipment, (Steering, steering wheel, park brake, shifter, modules W/ custom flash, etc.) please refer to the corresponding section of this manual.

Unique items, (side doors, body panels, roof assembly, seats, etc.) please refer to the corresponding section of this manual and also the Morgan Olson C-250 parts manual.

Helpful tip: On the parts website, you can create a saved list of items or just add the items to the shopping cart, then use the **shared list** feature to email your list to morganolsonparts@jimkeayford.com They will respond with pricing and availability information

FOR WARRANTY INFORMATION CALL 1-800-262-3437

ANY QUESTIONS OR CONCERNS SHOULD BE DIRECTED TO YOUR SERVICE PARTS REPRESENTATIVE AT 1-800-233-4823

At Morgan Olson, our quest for quality and safety is ongoing and therefore the specifications on the product described herein may vary over time.

Please contact Morgan Olson for the latest product information and available safety features and options.

Table of Contents

Section	Description	Page #
i.	Disclaimer	2
ii.	Introduction / Canadian Parts Distributor Information	3
iii.	Table of Contents	4-5
Section	Description	Page
1-1	Front Clip Removal / Installation	6
1-2	Front Grille	6
1-3	Head Lamp & Front Turn Signal Replacement	7
1-4	Headlamp Alignment / Aiming	7
1-5	Hood Replacement	7
1-6	Gas Spring Replacement	7
2-1	Front Bumper Replacement	8
3-1	Wiper System Replacement	8-9
4-1	Side Door Removal / Replacement	10
4-2	Lock Assembly	10
4-3	Side Door Lock Cylinder Assembly	10
4-4	Side Door Handle	11
4-5	Side Door Striker	11
4-6	Power Window Regulator	11
4-7	Power Window Glass	11
4-8	Window Rubber Seals	12
4-9	Side Door POGO Switch	12
4-10	Side Door POGO Switch @ A-Post	12
4-11	Lower Side Panels	13
4-12	Roof Skin	13
4-13	Roof Corner Caps	13
5-1	Dashboard	14
5-2	Dash Louvers	14
5-3	HVAC Assembly Removal & Installation	14-15
5-4	ECG / MCM / Radio / Power Window Modules	15
5-5	Engine Box Cover	15
5-6	Shifter	16
5-7	Steering Shafts & Gear Boxes	16
6-1	Side Mirrors	17
6-2	Front Mirror	17

Table of Contents

7-1	Fender Flares	17
7-2	Cargo Area Lamps	17
8-1	Rear Panels	18
8-2	Transom Plate	18
8-3	Transom	18
8-4	Rear Sill	18
8-5	Rear Lamps	19
8-6	Rear CHMSL (Center High Mount Stop Lamp)	19
8-7	Rear Camera	19
8-8	Rear Bumper	19
9-1	Exhaust System	20
10	Cargo Door Keyless Lock System	21
11	HVAC Operation & Service Manual	22-42
12	Transglobal Roll Up Door Maintenance Manual	43-58
13-1	Wiring Harness	59
13-2	Wiring Diagrams	60-91
14	Schematic Diagrams	92-136
15	FORD Modules with custom firmware	137

Section 1-1 to 1-3

Front Clip Removal and Installation

1. Open the hood and disconnect the two wires that connect to the side marker lamps (Amber) LH & RH
2. Remove the two front wheels.
3. Remove the inner wheel liners.
4. Remove 6 lock nuts 1/4-20 (3 per side) from the side fenders, forward of the step assemblies. (Accessible from the underside of the cab - green arrows)
5. Remove 10 lock nuts 1/4-20 (5 per side) from the side fenders - (accessible from within the cab - red arrows)

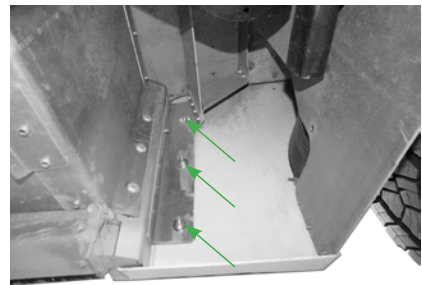
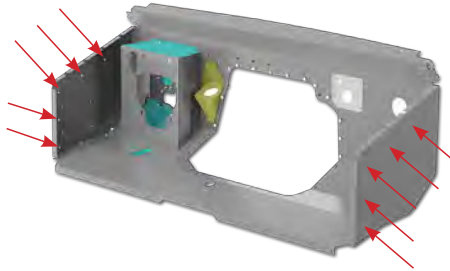
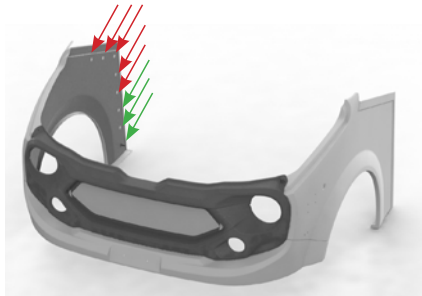

6. Remove two bolts at the side mirror support bracket.

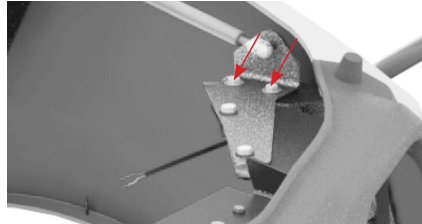
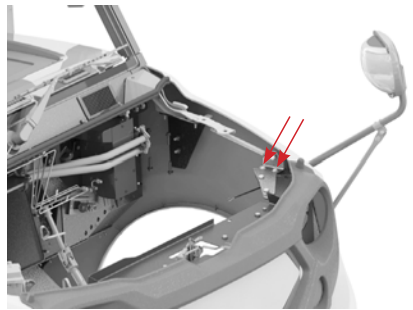

7. Remove two 1/4" lock nuts at the radiator shroud. (Bottom)

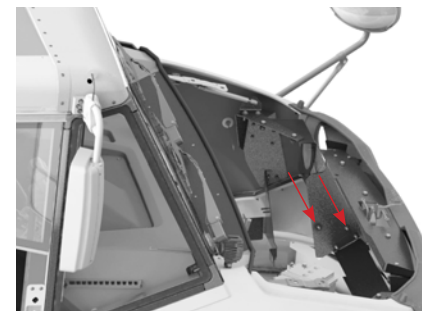

8. The front clip assembly is now ready to be removed. With one person on each side, pull the rear edge of the fender panels away from the cab just far enough for the studs to clear the holes in the cab skirts. Walk the clip assembly forward until it clears the chassis.

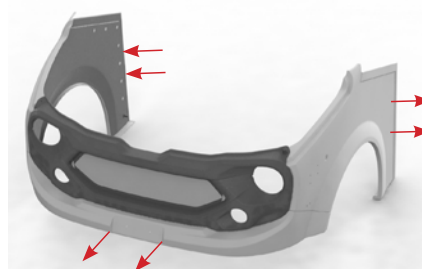

9. Install the front clip assembly by following these steps in reverse order

1-2 Grille Replacement

1. With the front clip assembly removed from the vehicle, locate the 8 rivets surrounding the grille and drill them out to remove the grille from the grille surround panel. (See section 1-1 - **Front Clip Removal**)
2. Inspect the brackets to make sure they are secured to the panel. If they are broken or unservicable, it is recommended to replace the panel.

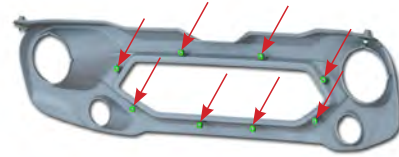

2. Remove the damaged grille and discard.
3. Position the new grille in place and secure with eight rivets, P/N 40200304
4. Install the Front Clip back onto the vehicle. (See section 1-1 - **Front Clip Removal**)

1-3 Headlamp/Turn Signal Replacement

1. Headlamp / bulb replacement. Remove three screws from the headlamp retainer ring.
2. Remove the retainer ring and save to reinstall
3. Remove the lamp and disconnect the wiring connector from the back of the lamp.
4. Unscrew the bulb and discard. Replace with bulb P/N H-5024, reconnect the wiring harness and insert the lamp back into the headlamp housing (basket)
5. Secure the lamp with the retainer ring and screws.



1-3 Headlamp/Turn Signal Replacement

1. To replace the headlamp basket assembly or turn signal, remove the front clip assembly, see section 1-1 **Front Clip Removal**.
2. With the front clip removed, unfasten the retaining screws from the headlamp assembly or turn signal.
3. Disconnect the wiring harness from the lamp.
4. Reconnect the wiring harness to the replacement lamp and fasten the lamp back into place using the screws that were removed in step one.
5. Headlamp replacement only, Verify proper headlamp alignment by following the headlamp aiming procedures, see section 1-4 **Headlamp Aiming**.

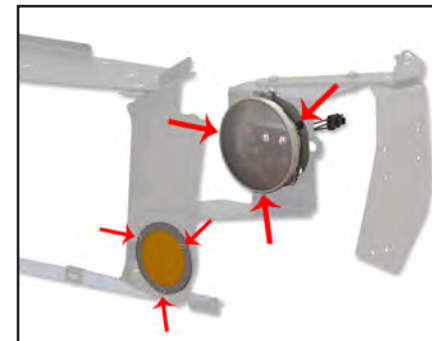

1-4 Headlamp Adjustment

Park the car on level ground. Find level ground where you can shine the headlights on the garage door or a flat wall. Make sure the car's tires have the proper inflation, the gas tank is at least half-full, and try to mimic the normal amount of weight you normally carry in the vehicle. Push on all four corners of the car to help level out the shocks and turn the headlights on.

Create a center axis. This next step is best done at dusk or dawn. Park the car about six feet away from the wall. Turn your headlights on low beam. Use the masking tape to mark the horizontal and vertical lines of the beam's center axis as it shines on the wall. The position of the tape should create a cross.

Section 1-3 to 1-6

Measure the difference between the two headlights. Take the measuring tape and measure the lines to see if both headlights have the same measurement. If the measurements don't match, note the difference, and lower the highest centerline to the same height as the lowest centerline mark. Some vehicles have integrated crosshairs within the headlight that help you find the center axis of the beam easily.

Back the car away from the wall. Using the measuring tape, measure the distance roughly 25 feet. Keeping the surface level, back the car so that the front wheels hit the 25-foot mark. Turn your headlights on and note where the brightest part of the headlight's beam hits the taped spot on the garage wall.

Prepare for the adjustment. Prepare for the adjustment by taking off the ring or bezel of the headlights, keeping the parts in a secure location. Make sure you have your screwdriver and a piece of dark cloth or cardboard handy. Be familiar with the location of both the vertical and horizontal adjuster screws. Having an assistant inside of the car helps with the actual adjusting process.

Adjust the vertical field. As you stand in the front of the car, have the assistant turn the headlights off. Next, put the dark cloth or cardboard over one headlight, and have the assistant turn the headlights on. Find the adjusting screw and turn the screws slowly clockwise to raise the height of the lights or counterclockwise to lower them. As you make your adjustment, make sure the most intense part of the headlight beam hits at or just below the vertical centerline you taped on the wall.

Adjust the horizontal field. Turn the screws clockwise to adjust the headlight inwards and counterclockwise to adjust them outwards. The headlight beam should fall just to the right of the center tapeline. Next, block out the adjusted headlight and do the same vertical and horizontal adjustment on the other headlight.

Fine-tune the adjustments. Keep tweaking the vertical and horizontal adjustment until the headlight beam's center axis lines up with the tape marks on the wall. Once you're satisfied with the adjustments, take the car for a road test, and if one of the headlights isn't quite up to par, repeat the above instructions.

Headlamp Aiming Device Specification may be found at the SAE Standards Website here. https://www.sae.org/standards/content/j602_195902/

1-5 Hood Replacement

1. Open the hood using the hood release lever in the cab.
2. Remove four bolts and washers from the hood hinge brackets (two each per side)
3. Remove the hood latch bracket bolts (.25-20x1" GD5)
4. Install the hood latch bracket to the new hood
5. Position the new hood in place and secure with the bolts & washers that were removed in step 2
6. Verify the hood opens and closes properly and is properly aligned so the latch and bracket make proper contact.
7. If needed, adjust the hood stop posts so the hood is at the proper height.



1-6 Gas Spring Replacement

1. Open the hood using the hood release lever in the cab.
 2. Remove the gas spring by pulling it away from the ball stud.
- (If the Ball Stud is damaged, replace with P/N 126106427)
3. Replace with Gas Spring P/N CS9017003

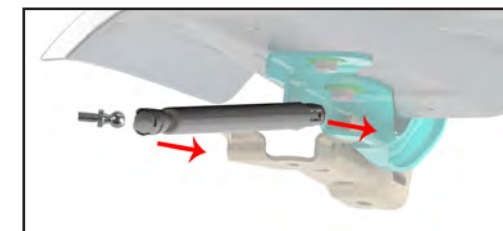

Section 2-1 to 3-1

2-1 Front Bumper Replacement

1. Remove Front Clip – (See Section 1-1 Front Clip Removal)

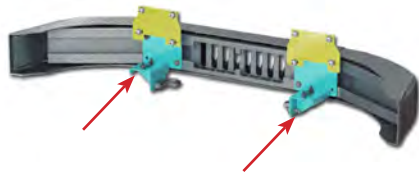

2. Remove two bolts per side where the front bumper brackets attach to the lower frame.

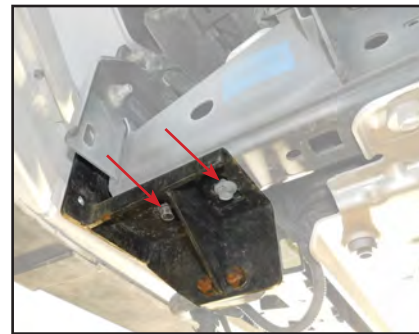

3. If the front bumper brackets are reusable, remove the bolts to release the bumper brackets from the bumper. (If the bumper brackets are no longer serviceable, remove the tow hooks and save for use on the replacement bumper brackets)

4. Attach the brackets to the new bumper.

5. Position the new bumper and brackets in place and secure with the bolts that were removed in step two.

6. Level the bumper to the floor.

3-1 Wiper System Replacement

1. Remove the Wiper Arms and Pivot Nuts (9/16" nut on the wiper arm 1-1/2" Pivot nut.)

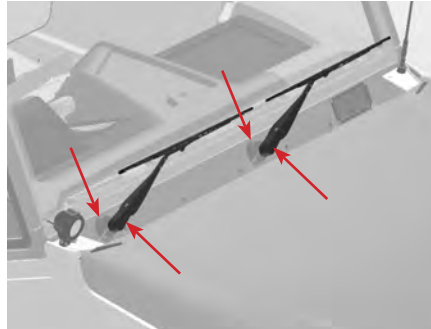

2. Open the hood using the hood release lever inside of the cab.

3. Disconnect the battery, remove it and set aside.



4. Remove the battery tray assembly and set aside.

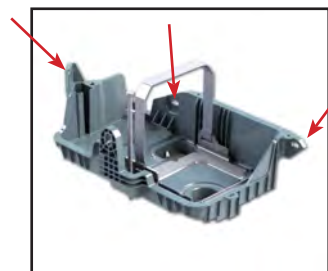

5. Unfasten the Fuse Block Assembly and pull it forward until it rests in the space where the battery tray was.

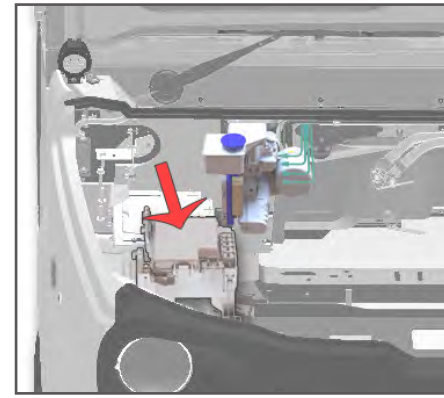
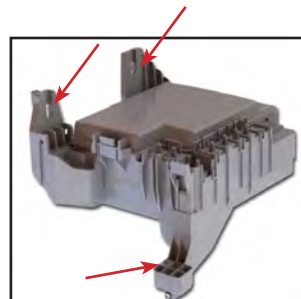

6. Unfasten the Master Cylinder Assembly from the firewall and disconnect the brake pedal.

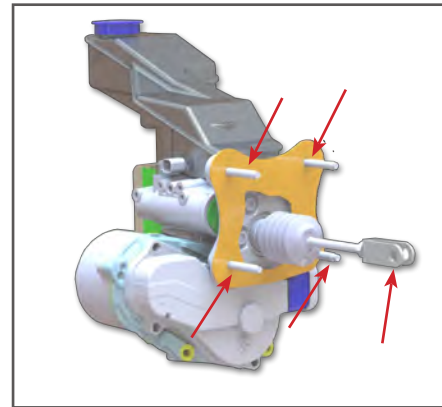

7. Free up the brake lines by pulling the retaining clips downwards. X4

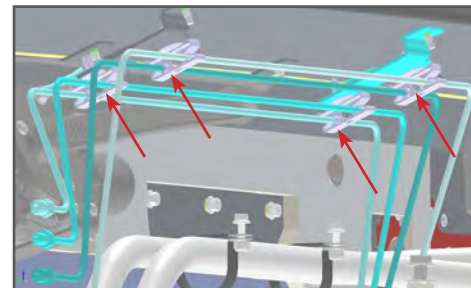
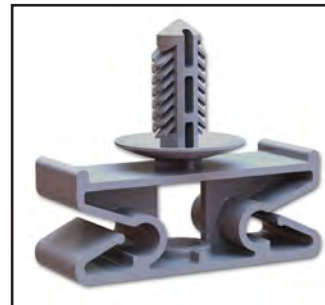

Section 3-1 cont.

8. Detach the heater hose bracket (leave the hoses attached)



9. Pull the Master Cylinder forward, next to the fuse box assembly to make space for the wiper system to be removed.

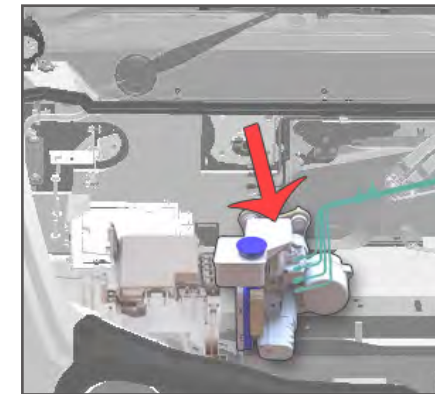

10. Unplug the wiper motor power connector.

11. Push the wiper assembly back and then down, rolling it out of position so it can be removed.

12. Position the replacement Wiper Assembly into place, align the tip of the pivots with the holes in the cowl, lift and roll the assembly into place.

13. Install the pivot nuts to hold it in place while the other assemblies are re installed.

14. Reconnect the wiper motor wire harness

15. Reattach the heater hose bracket.

16. Reattach the Master Cylinder to the firewall and the Pedal.

17. Re install the Fuse Block Assembly.

18. Re install the battery tray assembly.

19. Re install the battery.

20. Connect the battery cables.

21. Close the hood, tighten the pivot nuts and install the Wiper Arms (9/16" nut)

22. Reconnect the washer fluid hoses.

Section 4-1 to 4-3

4-1 Side Door Replacement

* Roadside Door Only – Remove the side camera from the mounting bracket and let it hang, remove the bracket, save for re installation, from the inside, pull the camera wire to take up the slack so the camera is close to the side wall.

1. Remove the bolts along the bottom edge of the lower door seal bracket.

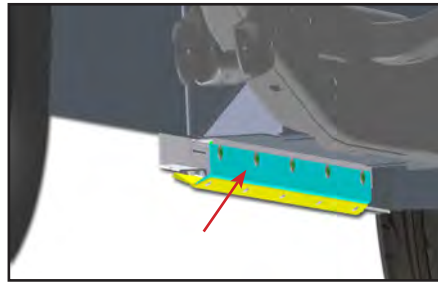

2. Remove lower brush seal and retainer.

3. Remove the door guide mounting bracket & door guide.

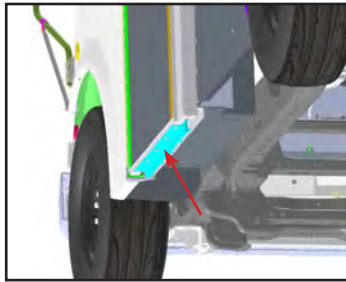

4. Remove the Door Track Filler Plate.

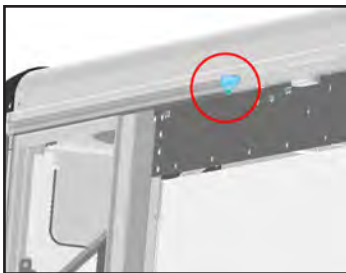

4. Pull outwards on the bottom of the door and slide it to the rear until it is clear of the door track.

5. To install the side door, follow these steps in reverse order.

6. To remove the door track assembly, unfasten the clips along the edge of the head liner and pull the head liner back to expose the door track nuts.

7. Remove the eight door track nuts.

8. Pull down on the door track assembly to remove it from the channel in the roof rail.

9. Install the new door by following these steps in reverse.

10. To adjust the bottom of the door in and out, loosen the 5 bolts at the door track filler plate.

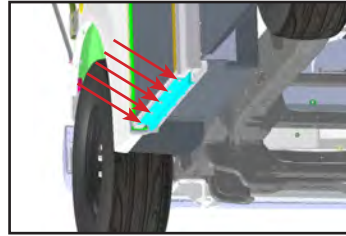

11. Move the door in/out to line up with the A-Post. Tighten the bolts.

12. Adjust the Striker and POGO switch to align with the door.

See Section 4-5 Side Door Striker
See Section 4-9 Side Door POGO

4-2 Side Door Lock

1. Mark the shaft end with a marker to assist with alignment during reassembly. (If you have previously replaced a lock assembly and you saved the red alignment tab, you can use that instead of marker to keep the mechanism aligned)



2. Remove four lock nuts and washers.
3. Pull the lock assembly away from the door to remove.
4. Disconnect the wire harness.
5. During reassembly, make sure the alignment marks are lined up correctly.

Note* If replacing the door lock with a new lock assembly, it will come with a removable red tab installed. This tab will get pushed out by the lock cylinder shaft during installation. Save this red tab for reuse.

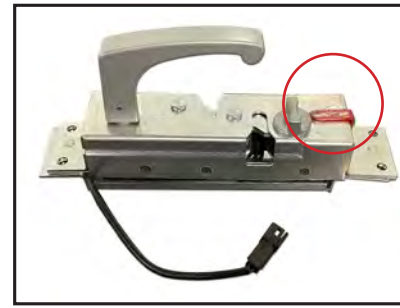

Install the new lock by following these steps in reverse order.

4-3 Side Door Lock Cylinder



1. Remove the side door lock assembly. (See section 4-2 Side Door Lock Assembly)

2. With the side door lock assembly removed, you will be able to access the lock cylinder retaining clip.

3. Slide the retaining clip off the lock body to release the lock cylinder.

4. Replace the lock cylinder by following these steps in reverse order.

4-4 Side Door Handle



1. Remove the Side Door Lock Assembly. (See section 4-2 Side Door Lock Assembly)

2. From the outside of the vehicle, pull the door handle away from the door to remove.

3. Remove the lock cylinder and install it onto the replacement door handle assembly. (See section 4-3 Side Door Lock Cylinder)

4. Install by following these steps in reverse order.

5. Adjust the door striker for proper alignment if needed.

4-5 Side Door Striker

1. With the door in the open position, remove two lock nuts, washers & Bolts located in the A-Post.



2. Pull the latch striker inwards to separate it from the A-Post

3. Position the new latch striker in place and secure with bolts, nuts and washers that were removed in step 1

4. Adjust the door striker height to align with the door latch.

Section 4-4 to 4-7

4-6 Power Window Regulator

1. Remove the side door (See section 4-1 Side Door Replacement)

2. Remove the side door Cover Panel screws and set aside.

3. Disconnect the motor harness.

4. Remove three horizontal support channels. (12 bolts & 8 nuts)

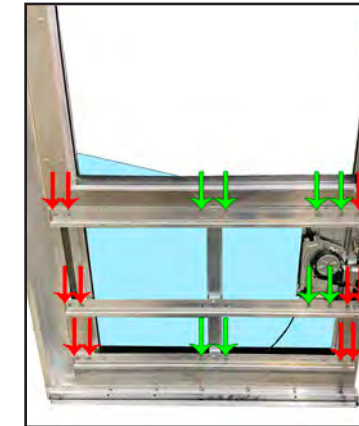

5. Remove two bolts at the window mounting bracket. Remove the regulator and discard.

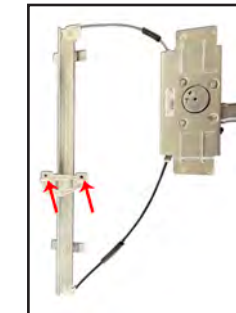

6. Install the top horizontal channel and secure with 4 bolts.

7. Position the new regulator into place and secure with 4 nuts.

8. Install the two bolts at the window mounting bracket.

9. Install the two lower horizontal supports and secure with the remaining fasteners. (8 bolts and 4 nuts)

10. Reconnect the wire harness.

11. Install the cover panel.

12. Install the side door on the vehicle. (See section 4-1 Side Door Replacement)

4-7 Side Door Window Glass

1. Remove the side door (See section 4-1 Side Door Replacement)

2. Remove the Cover Panel & Window Regulator (See section 4-5 Side Door Power Window Regulator)

3. Remove the lower inner door skin. (4 bolts & washers)



4. Remove the window seal retainer. (3 Phillips screws)



5. Lower the window and work the forward edge of glass out of the frame.

6. To reinstall, follow these steps in reverse.

Section 4-8 to 4-10

4-8 Side Door Window Seals

The horizontal window seals have raised edges that hold them into the groove.

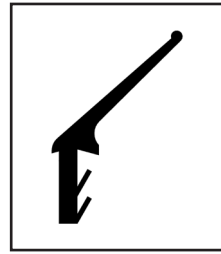

1. Pull upwards on the seal until it comes free of the door frame.
2. Inspect the channel to make sure it is free of debris.



3. Insert the replacement seal firmly into the channel ensuring that it is seated properly.
4. To replace the window seals in the vertical tracks, pull the old seal out of the channel. See sections **4-1, Side Door Removal, 4-6 Power Regulator Removal, 4-7 Side Door Glass removal.**

5. Inspect the channel(s) to make sure they are free of debris.

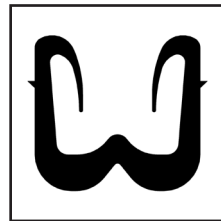

6. Insert the new seal into the channel and press firmly to ensure it is seated in the channel.
7. Reassemble by following these steps in reverse order.

4-9 Side Door Pogo Switch

1. Remove the Side Door Cover Panel (See Sections **4-1 Side Door Removal**)
2. Remove two screws, washers and lock nuts to release the Pogo Switch.

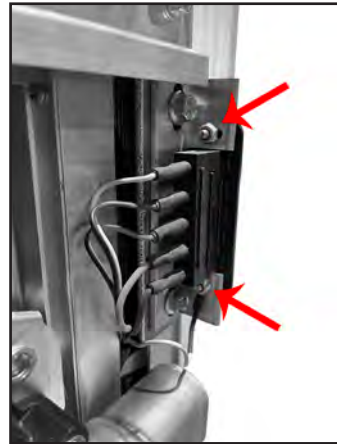

3. Disconnect the wiring from the rear of the switch and attach them to the new switch.
4. Reassemble by following these steps in reverse order.
5. Verify the switch contacts are aligned properly. Horizontal and vertical adjustment can be made by moving the position on the Pogo Switch mounting bracket.

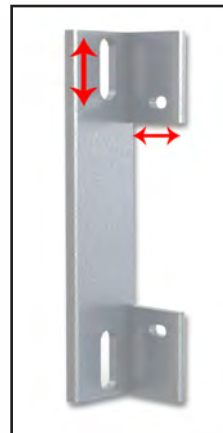

4-10 Pogo Switch @ A-Post

1. Remove two screws, lock nuts and washers from the pogo switch.



2. Carefully pull the pogo switch out of the A-Post and disconnect the wires.
3. Reconnect the wires to the new switch and install in the A-Post by following these steps in reverse order.
4. Verify the switch contacts are aligned properly.

Horizontal and vertical adjustment can be made by moving the position on the Side Door Pogo Switch @ the mounting bracket.

Switch Wiring

Pin1	White	Ground
Pin2	Red W/Blk	Unlock
Pin3	Blue W/Blk	Lock
Pin4	Yellow	Motor Up
Pin5	Green	Motor Down
Ring	White	Frame Ground

Section 4-11 to 4-13

4-11 - Lower Side Panels

1. Remove the rear wheel fender flare **See Section 7-1 Fender Flare**
2. With the fender flare removed, drill out the rivets using a 1/4" drill bit.

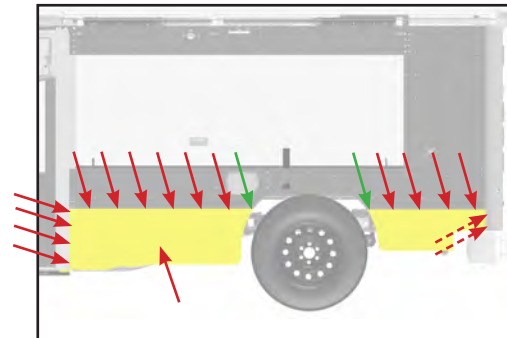
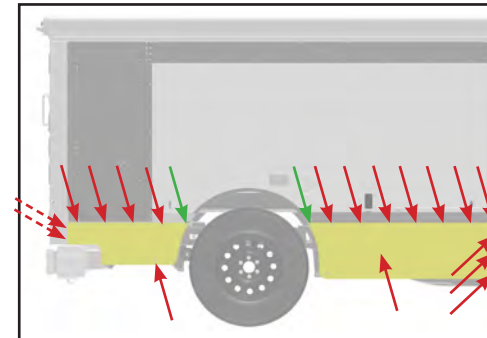

3. Remove the panel and discard.
4. Position the replacement panel into place and install with rivets,

P/N 49013105
.25" (Green Arrows)

P/N 40200304
.25" (Red Arrows)

4-12 - Roof Skin

1. Drill out all of the rivets around the perimeter of the roof skin along the edge of the roof rail interlocks with 1/4" bit.

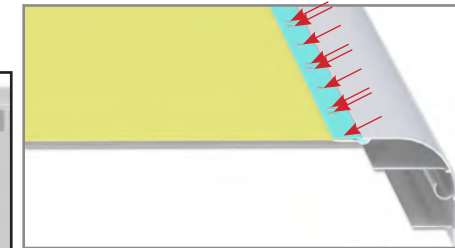

2. Remove the damaged roof skin and discard.
3. Apply foam tape, P/N 42005039 to the top edge of the roof bows.

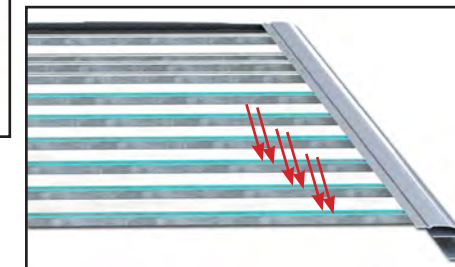

4. Position the new roof skin, P/N 209010412 in place.
5. Reinstall the interlock rails.
6. Install rivets, P/N 40200662 around the perimeter.

4-13 - Roof Corner Caps

1. Remove the side mirror. **See Section 6-1 Side Mirror**
2. Drill out the rivets in the corner cap with a 1/4" drill bit.
3. Remove the Phillips screw and washer. (Green Arrow)

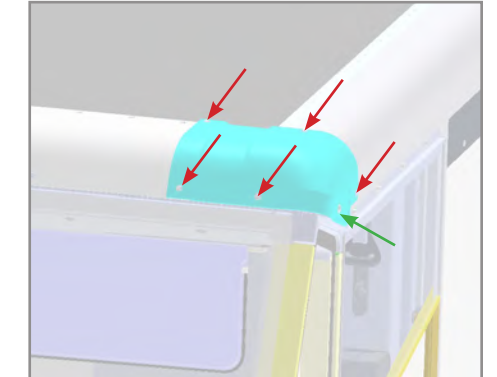

4. Remove any caulk/sealant residue.
5. Apply new sealant, P/N 41002043
6. Position the new corner cap in place and secure with rivets P/N's 49013051 X2 40200302 X3
7. Replace the screw and washer that were removed in step 3.
8. Apply thumb putty to make a water-tight seal around the edges. P/N 41002602

9. Reinstall the side mirror **See Section 6-1 Side Mirror**

Section 5-1 to 5-3

5-1 Dash Board

1. Remove 6 screws from the LH Dash Inset panel P/N 49013240

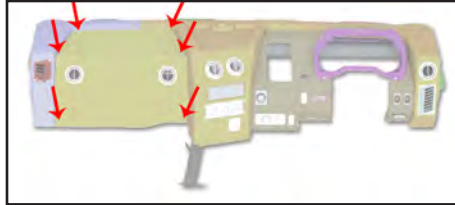

2. Lift the panel out and set aside.

3. Remove the heater plenum P/N 49013029 by removing the retaining clips that hold the plenum to the top of the heater assembly. Detach the three heater hoses from the RH side of the plenum, lift the plenum out and set aside.

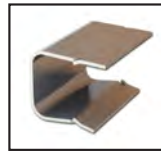

3. Remove 2 bolts at the bottom left edge and 2 screws, 1 at the front center and 1 at the rear left corner of the Dash LH P/N 49013239

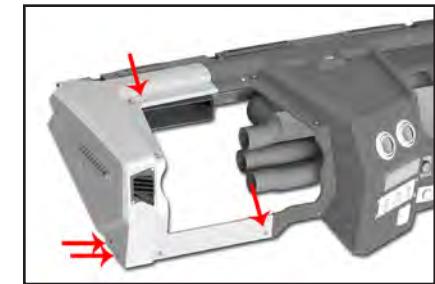

4. Lift the LH Dash and pull forward, set aside.

5. Remove 6 screws from the RH Dash Inset, P/N 49013237

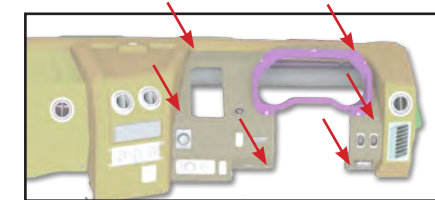

6. Unplug the wiring harness on the rear of the controls. (Start/Stop, Power Windows, 4WD, etc)

7. Carefully lift the dash inset (with Bezel still attached) and set aside.

Disconnect the wiring harness at the back of the control panels.

8. The dash RH and the defroster plenum will come out as a single piece, do not try to separate these two items at this stage.

9. Remove the four screws along the front edge of the defrost plenum.

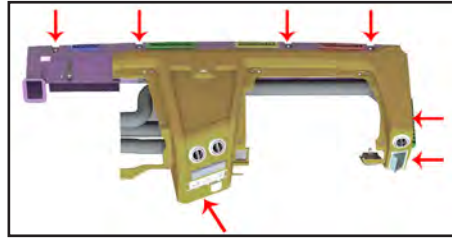

10. Remove two bolts at the RH side of the dash.

11. Remove the screws at the support bracket in the front center of the dash. Disconnect any remaining wiring harness, lift the dash out and set it aside.

12. To reinstall the dash assembly, follow these steps in reverse order.

9. After removing the Dash, Separate the cross plenum from the Dash by removing the screws at the mounting brackets.



10. Remove two screws each from the side defrost louvers and set aside.

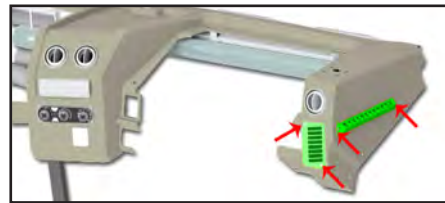

11. Once separated, disconnect the hose from the Louver and remove the Louver retaining nut, then remove the Louver from the dash panel.

12. Install the new Louver and re-assemble by following these steps in reverse order.

5-2 Dash Louvers

1. Remove LH Dash Inset (See Section 5-1 Dash Removal)

2. Unscrew the Louver retaining nut and remove the Louver from the dash inset panel.

3. Insert the new Louver and secure in place with the new Louver retaining nut.

4. Re install the LH dash Inset

5. Center Louvers – (See section 5-1 Dash Removal)

6. Disconnect heater hoses from the Louvers and remove the Louver retaining Nut.

7. Install the new Louver and reassemble by following these steps in reverse order.

8. RH Dash Louver will also require the separation of the Dash and the Front Defroster Plenum. (See Section 5-1 Dash Removal.)

5-3 HVAC Removal

1. Remove LH Dash Inset and LH Dash (See section 5-1 Dash Removal)

2. Disconnect the heater wiring harness.

3. Disconnect heater hoses.

4. Remove Retainer Clip at the A/C Expansion Valve.



4. Disconnect A/C lines.

5. Disconnect Air Intake Assembly (3 Screws)

Section 5-3 to 5-5

5-3 HVAC Removal Continued

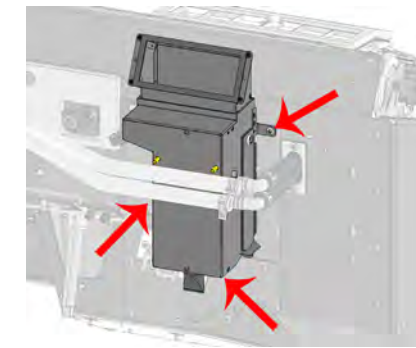

6. Remove A/C Panel P/N 209005419 (9 Screws)

7. Remove Fresh Air Intake Panel P/N 209005420 (11 Screws)

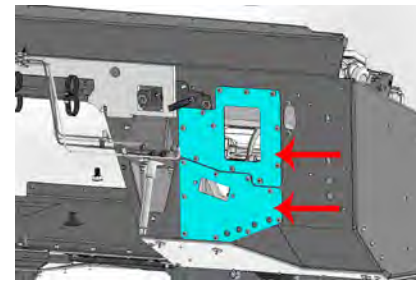

8. Reach into the opening and remove 4 HVAC mounting Lock Nuts & Washers.

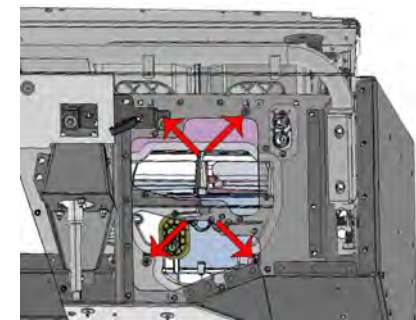

9. From the inside of the vehicle, pull the HVAC system away from the dash wall.

10. Reinstall the new HVAC by following these steps in reverse order.

*A/C t Weight is 1.87 lbs

5-4 PDM / MCM / Radio / PWR Window

1. Remove the Dash Assembly (See Section 5-1 Dash Board)

2. Disconnect the wiring harness to the module.

3. Remove fasteners that secure the module to the mounting bracket.

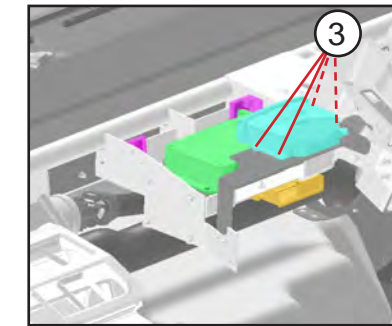

NOTE*

Some OEM FORD modules are flashed with a custom firmware.

BCM Module
PCM Module
RCM Module
ECG Module
TCCM Module
PDB Module
I/P Cluster

Ensure that you are using the correct firmware when replacing modules.

4. Reinstall by following these steps in reverse order.

5-5 Engine Box Cover

1. Remove the Dash Assembly (See Section 5-1 Dash Board)

2. Remove the Dash Board Support Brackets.

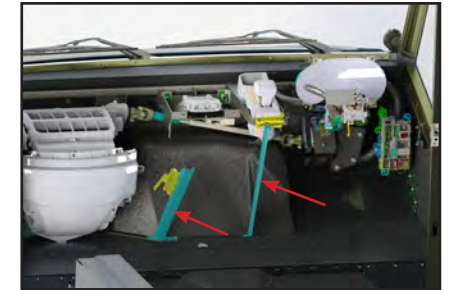

3. Remove the fasteners around the perimeter of the engine box cover.

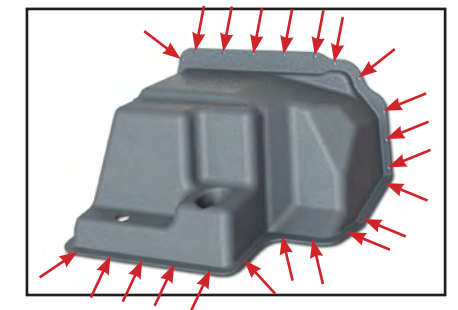

4. Pull the engine box cover away from the dash panel and set aside.

5. Reinstall by following these steps in reverse order.

Section 5-6 to 5-7

5-6 Shifter

1. Remove the RH Dash Insert.
(See section 5-1, steps 5-7 to remove the RH Dash Inset)

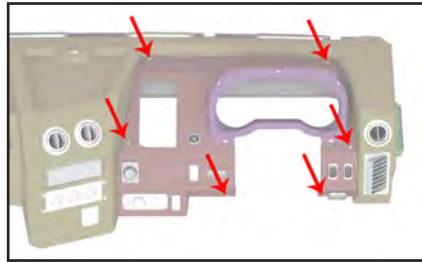

2. Remove the dash support leg.

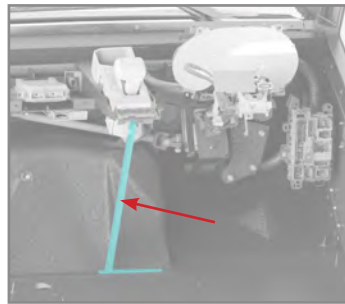

3. Remove 4 bolts to free the shifter assembly.

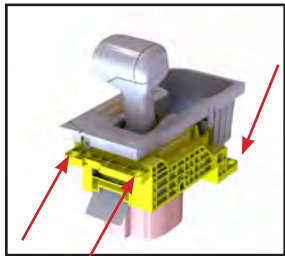

4. Disconnect the wiring harness from the shifter.
5. Lift the shifter assembly up and away from the sub dash mounting assembly
6. Reinstall by following these steps in reverse order.

5-7 Steering Shafts & Gear Boxes

1. Remove Dash Board (See Section 5-1 Dash Removal)

2. Remove Steering Column Cover.
(2 screws at the side closure panel & 2 screws at the bottom.)

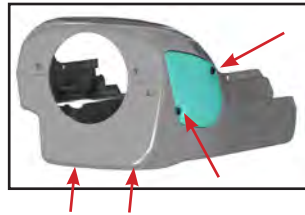

3. Disconnect Turn Signal Harness Connectors (x3)

4. Loosen the bolt that connects the steering column to the gear box shaft.

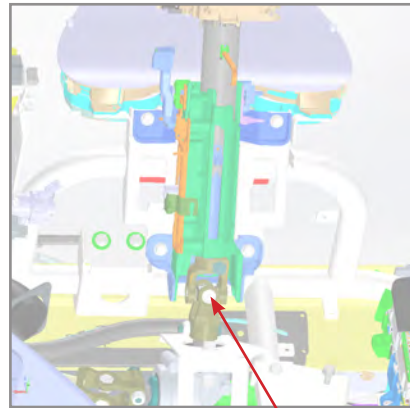

4. Remove Steering Column - 4 bolts that attach the column to the cross frame.

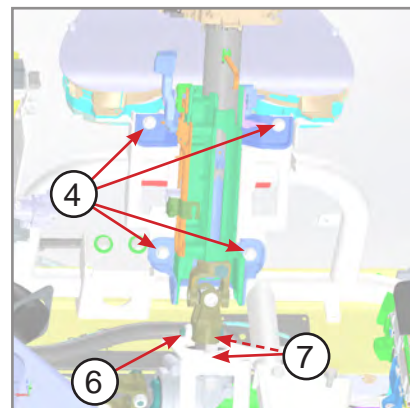

5. Remove Steering Column and set aside.

6. Remove 2 bolts at knuckles.

7. Remove 2 bolts at top of gear box to the cross frame.

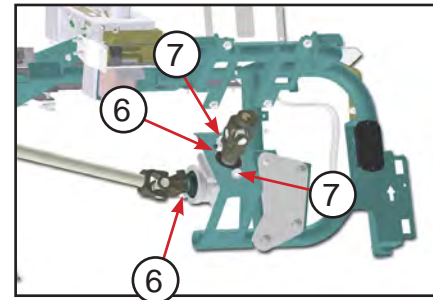

8. Pull the curbside gear box downward to separate it from the bracket.

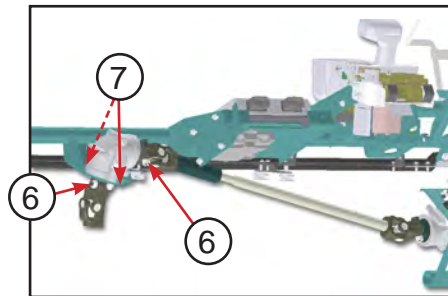

9. Lift the roadside gear box upwards to separate it from the bracket.

10. Replace the gear box and re-assemble by following these steps in reverse order.

6-1 Side Mirrors

1. Disconnect the battery cable.
2. Remove the speaker closest to the mirror by removing the four screws that hold the speaker in place.
3. Unplug the speaker wires and set the speaker aside.
4. Remove the visor bracket and set aside.
5. Remove the fasteners along the edge of the headliner and pull the headliner back enough to allow access to the mirror fasteners.
6. Unplug the mirror wiring harness.
6. Remove the grommet at the corner cap and pull the mirror power wire out until the connectors are clear of the hole.
7. Remove the 3 lock nuts that secure the mirror. (They are located in the corner casting)



8. Pull the mirror away from the vehicle and discard.
9. Position the replacement mirror in place and secure with three lock nuts.
10. Feed the wire harness through the hole and work the grommet into place to provide a weathertight seal.
11. Connect the mirror wire harness connector.
12. Install the head liner, visor brackets and speaker.
13. Re connect the battery and verify proper operation.

Section 6-1 to 7-1

6-2 Front Mirror

1. Remove the fastener at the brace arm.
2. Remove four fasteners at the mirror base.



3. Remove the mirror assembly and discard.
4. Position the replacement Mirror Assembly into place and secure with the base plate and fasteners that were removed in step 2.
5. Replace the fasteners that were removed in step 1.
6. Adjust the mirror as needed.

7-1 Fender Flares

1. Remove screws around the outer edge of the Fender Flare. (7 Screws)
2. Remove the Flare and discard.
3. Position the replacement flare and secure with the screws removed during step 1 or with new screws.

Do Not Caulk

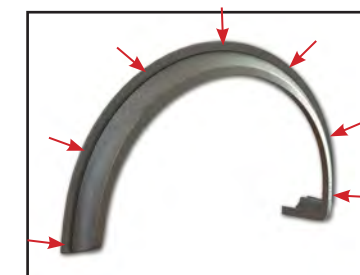

7-2 Cargo Lamps

1. Remove four screws, lock nuts and washers.



2. Disconnect the wiring (2-Bullet connectors)
3. Remove the lamp and discard.
4. Connect the wires to the new lamp and position in place.
5. Secure with the bolts, lock nuts and washers that were removed in step 1.

Section 8-1 to 8-4

8-1 Rear Panels

1. Drill out the Rivets using a 1/4" drill bit. top, inside & bottom.

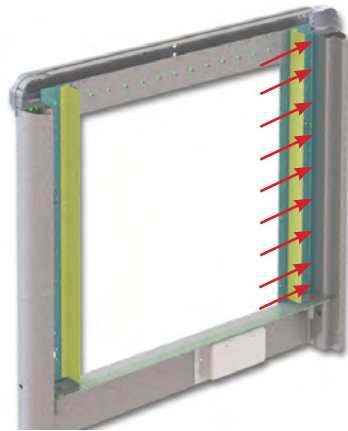
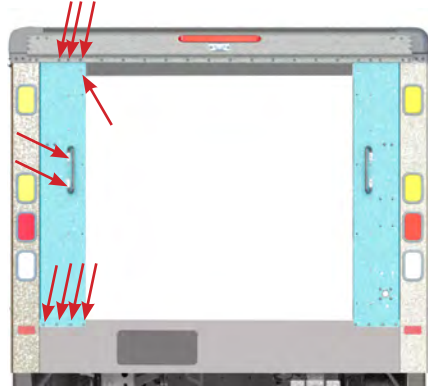

2. If the grab handle is reusable, remove and set aside for reuse.
3. RH Panel Only, also drill out the rivets at the lamp switch bracket and lock cable bracket, lock cylinder guard bracket.
4. Remove the panel and discard, position the new panel into place and secure with new fasteners.
P/N 41002062 Sealant Grey,
P/N 1117888 Pin and P/N 1117865 Collar,
P/N 40200304 Rivet,
P/N 1117815 Bolt,
P/N 40100044 Lock Nut

8-2 Transom Plate

1. Drill out the Rivets using a 1/4" drill bit and remove the Transom Plate. The top rivet is accessible from the inside.

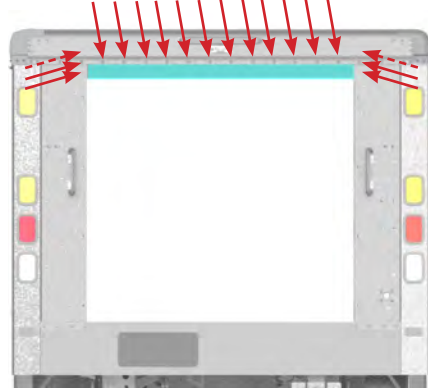

2. Position the new Transom in place and secure with rivets.
P/N 40200304 X16.

8-3 Transom

1. Drill out the Rivets using a 1/4" drill bit and remove the Transom Plate. The top rivet is accessible from the inside.

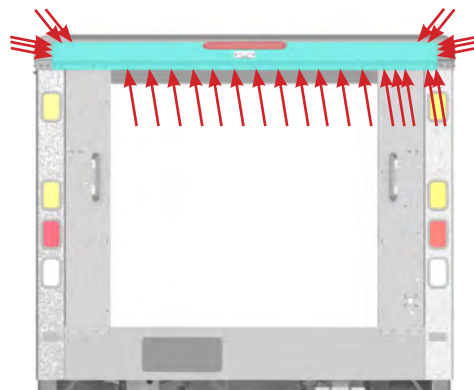

2. Disconnect the wiring from the CHMSL and Camera, remove and set aside.
3. Position the new Transom in place and secure with rivets.
P/N 40200304 X16.
4. Reattach the CHMSL and Camera, reconnect the wiring.

8-4 Rear Sill

The rear sill is secured with four Pins/Collars and four Magna Lock Hucks on each side and 12 counter sunk magna lock hucks along the edge.

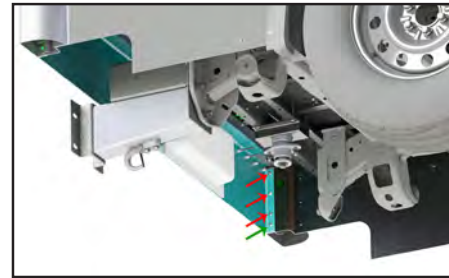
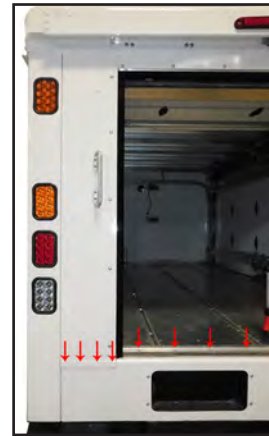

1. Use a center tap to mark the center of the Pins before drilling them out using a 1/4" drill bit.
 2. Disconnect the power wires for the license plate lamps.
- If the license plate holder is reusable, drill out the four rivets and remove the license plate holder, set it aside for reinstallation.
3. Position the new rear sill into place and secure with the same fasteners.
P/N 40200302 Rivets X2,
P/N 40200304 Rivets X6,
P/N 1117888 Pin and
P/N 1117865 Collar X8 each,
P/N 49013105 Counter Sunk Rivet X12.
 4. Attach the license plate holder using rivets P/N 1117061 X4.
 5. Reconnect the power wires to the license plate lamps.

8-5 Rear Lamps

Note* The Amber lamps are not the same, the top lamp is a strobe and the other is a standard 2-wire LED.

1. The rear lamps are mounted with a grommet. Use a small flat blade screwdriver to work around the edge of the lamp to free it from the grommet.



2. Pull the lamp away from the vehicle to expose the wiring.
3. Disconnect the wires and discard the lamp.
4. Connect the wires to the new lamp and push it into the grommet.

A small amount of soapy water may be applied to help the lamp fit into the grommet.

8-6 CHMSL

(Center High Mount Stop Lamp)

1. Remove two Phillips screws (Self Tappers)

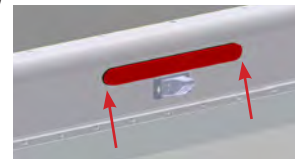

2. Pull the lamp away from the vehicle to expose the wiring.
3. Disconnect the power wires.
4. Connect the power wires to the new lamp and install with the screws.

Section 8-5 to 8-8

8-7 Rear Camera

1. Disconnect the Camera wires on the inside of the cargo area.
2. Remove two screws that attach the camera to the base.

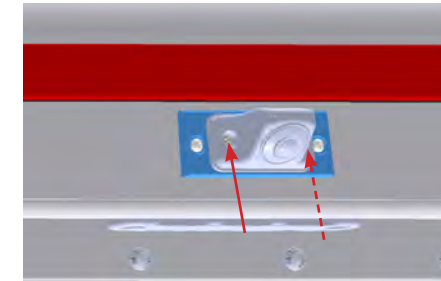

3. Remove the camera, camera wire and grommet.
4. The aiming plate should remain fastened to the vehicle.
5. Insert the wire on the new camera into the hole and seat the grommet securely into the hole.
6. Position the camera in place and secure with the screws removed in step 2
7. Reconnect the camera wires.

3. Inspect the bumper brackets, if they are damaged, replace the bumper brackets as well. (Steps 4, 5, 6, 7, & 8)

4. Remove the frame mounting bolts, Nuts & Washers. (3 each per side)

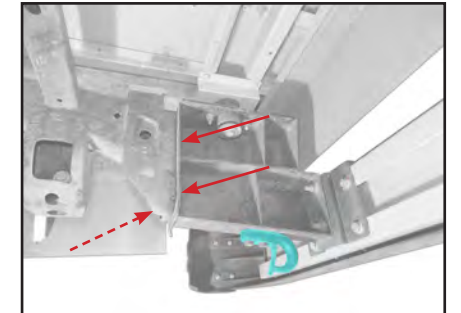

5. Remove the nuts and washers from the Body Mounting Support.

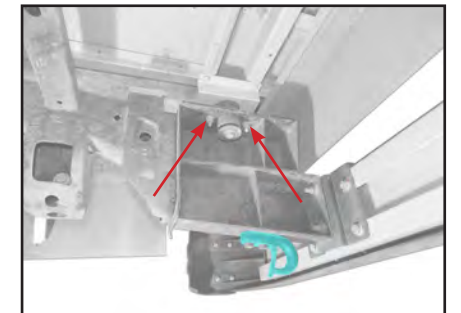

6. Remove the Mounting Brackets.

7. Remove the tow hooks from the brackets and install those on the new Brackets.

8. Position the new brackets in place and secure with Nuts, Bolts and Washers from step 5.

9. Attach the side covers to the new Rear Bumper Assembly.

10. Position the rear bumper into place and secure with the bolts from step 1.

11. Level the bumper to the floor.

8-8 Rear Bumper

1. Remove 3/4" bolts (4 per side)

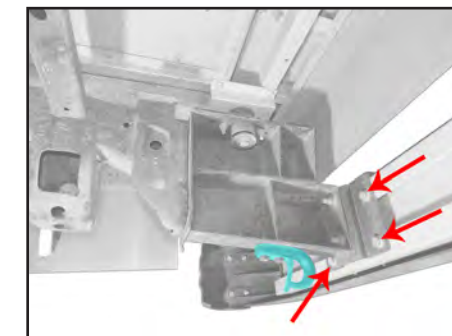

2. Remove the rear bumper assembly.

If the side covers are reusable, remove those and set aside for re installation.

9-1 Exhaust

From the exhaust header to the rear of the muffler is OEM FORD F-250 components.

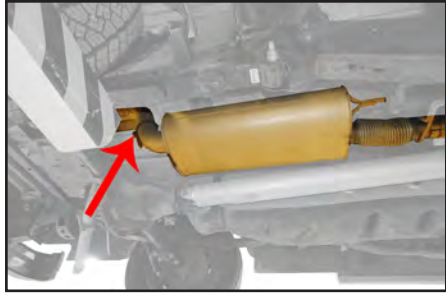

From the rear of the muffler to the tail pipe may be supplied by Morgan Olson.



10-1 Lock Cylinder Replacement

1. Remove three screws / lock nuts at the Keyless Cover Panel.

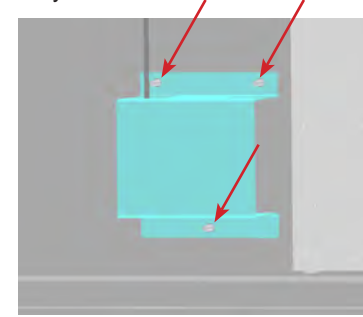

2. Remove the cover and set aside.

3. Loosen the collar on the lock shaft.

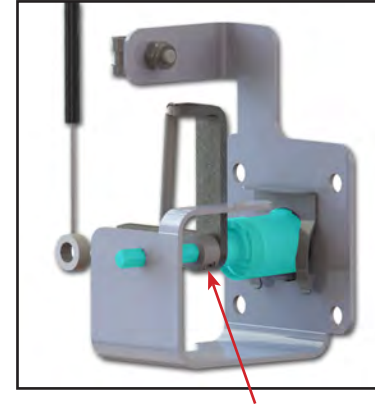

4. Remove the retaining clip by sliding it upwards.



5. Slide the Lock Assembly away from the vehicle. The retaining collar and the key link will be loose as the lock shaft is removed, try not to let them fall or get lost.

6. Slide the new lock body assembly onto place. The lock shaft should go through the key link and the retainer collar then through the rear of the lock cylinder bracket.

7. Secure the lock assembly by reinstalling the retainer clip.

8. Tighten the set screw in the collar.

9. Verify proper operation before installing the cover plate back in place.

10. Install the cover plate and secure with the three screws and nuts removed in step one.

10-2 Solenoid Replacement

1. Disconnect the Solenoid power wire.

1. Remove the Screws, Nuts and Washers to release the lock mechanism from the side wall.

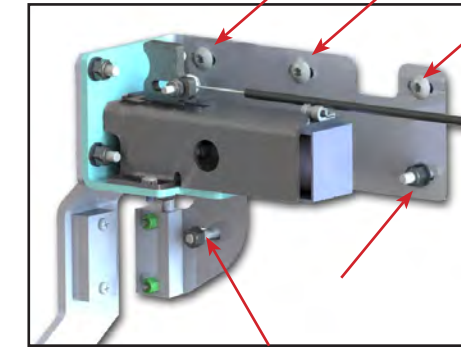

2. Remove 4 screws to release the Solenoid from the housing.

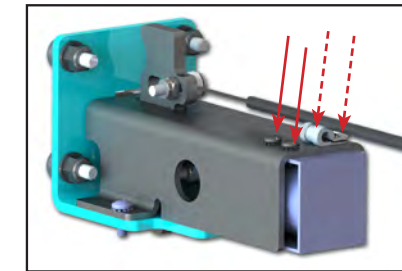

3. Slide the Solenoid out of the housing. The center pin will remain attached to the striker, the spring will be loose and may fall out.

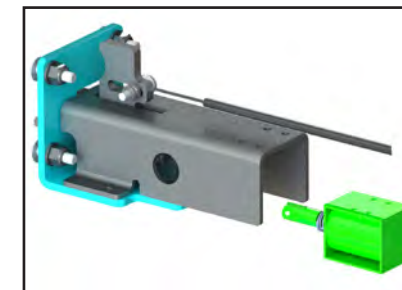

4. Discard the old Solenoid frame.

5. Inspect the center pin, it should appear to be clean and polished. If it is not, use the replacement center pin that comes with the new Solenoid.

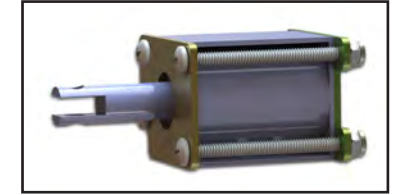

6. Slide the spring onto the center pin and insert the new Solenoid frame into the housing.

7. Reattach using the 4 screws removed in step two.

8. Reinstall the lock assembly using the screws, nuts and washers that were removed in step one.

9. Verify that the lock is working smoothly. If adjustment is needed, you may loosen the cable bolt at the top of the lock.

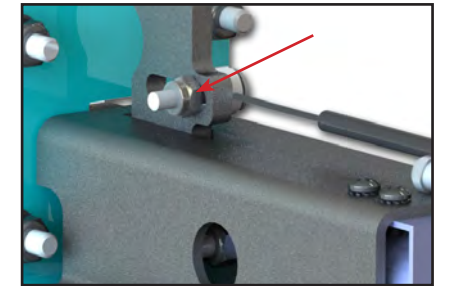

10. Extend the striker as far out as it will go and retighten the cable bolt.

11. Insert and turn the key to make sure the lock releases the door to open.

Keyless MCM Module P/N 49013566
Operators FOB P/N 239027252
Pairing FOB P/N 239027253

For Keyless Operation & FOB Enrollment Procedures, Please see the document, [C250 FOB Enrollment @ www.morganolsonparts.com](http://www.morganolsonparts.com)

1.0 Basic Description

OPERATION & SERVICE MANUAL

HEAT, VENTILATION, AIR CONDITIONING
(HVAC) Unit and Control



The HVAC unit consists of components designed to provide air that has been conditioned to the occupants of the vehicle. The unit is mounted under the dash. The evaporator core, expansion valve, heater core, fresh/recirculate door and actuator, temperature door and actuator, mode door and actuator, blower motor, and recirculation air filters are located within the unit.

2.0 System Operational Description

Air Distribution (General)

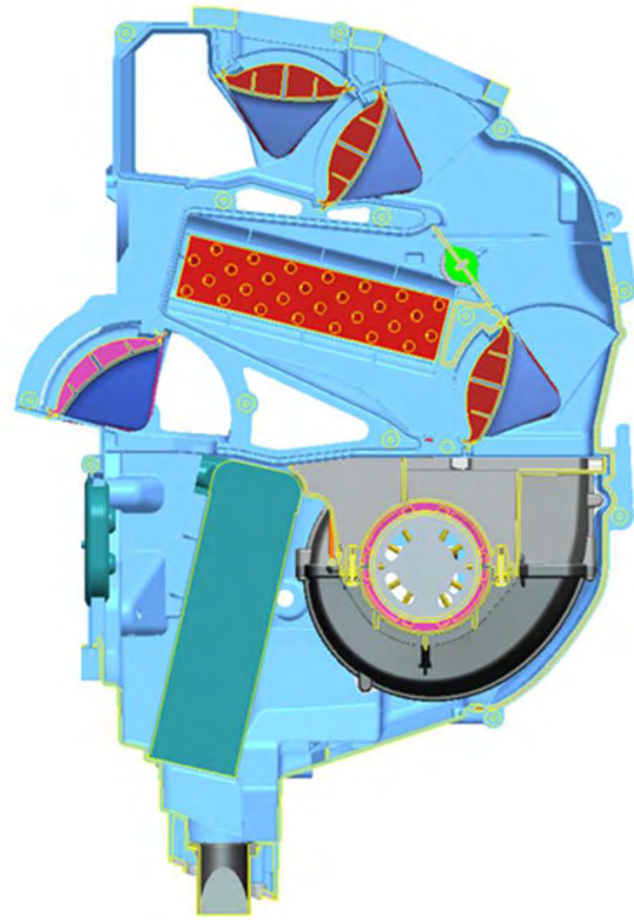

Figure 2
Cross-Section of HVAC Unit

The electrically actuated fresh/recirculate air door is controlled by the mode control knob on the HVAC control panel. When the door is in the recirculate position, outside air is blocked from entering the unit. Recirculated air, enters the HVAC unit through recirculation filters located on each side of the HVAC unit. When the fresh/recirculate air door is in the fresh air position, fresh air from outside of the vehicle enters the HVAC unit. The air enters the evaporator, flows through the blower assembly and then, is distributed through the air distribution system.

The electrically actuated temperature blend door is controlled by the temperature control knob on the HVAC control located on the instrument panel. The electrically actuated temperature blend door distributes air from the blower assembly, either through the heater core for full heat, partially through the heater core or around it for AC, depending on the temperature selected from the HVAC control. With a blend system, engine coolant always flows through the heater core.

There are two electrically actuated mode doors that are controlled by the mode control knob on the HVAC control panel. The doors are located at the top of the HVAC unit and are controlled through a set of gears and a cam (kinematics). These mode doors distribute air to the air outlets (floor vents, panel vents, and/or defrost vents) based on the mode selected.

The speed of the blower motor, which controls the volume of air moving through the system, is selected by the blower speed control knob on the HVAC control panel.

2.1 AIR DISTRIBUTION

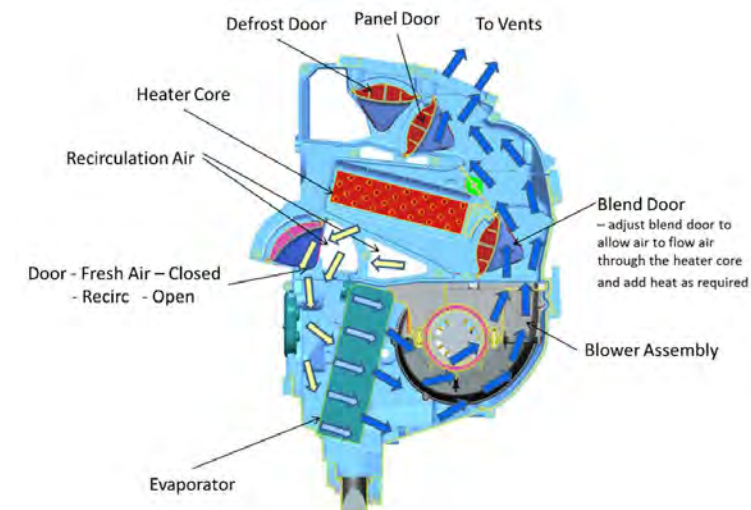

3A. MAX AC, RECIRCULATION MODE, PANEL

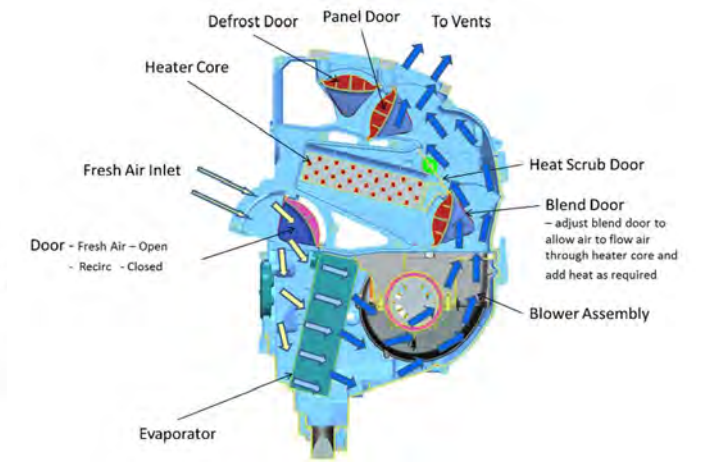

3B. NORMAL AC, FRESH AIR, PANEL

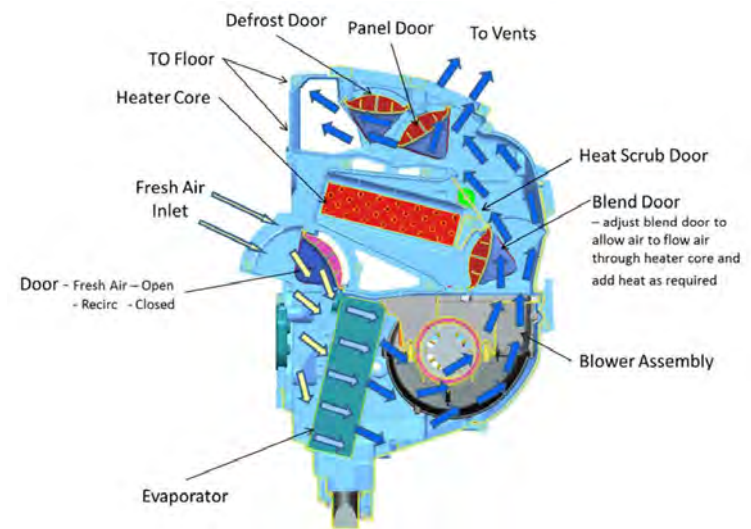

3C. NORMAL AC, FRESH AIR, FLOOR/PANEL

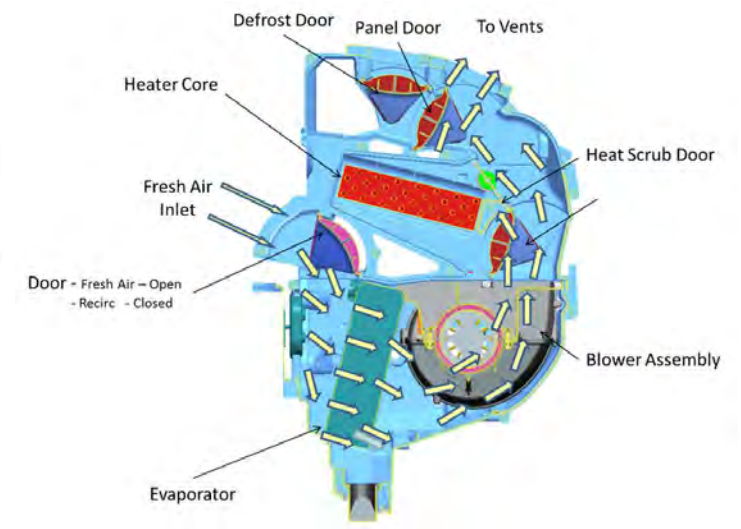

3D. FRESH AIR, PANEL

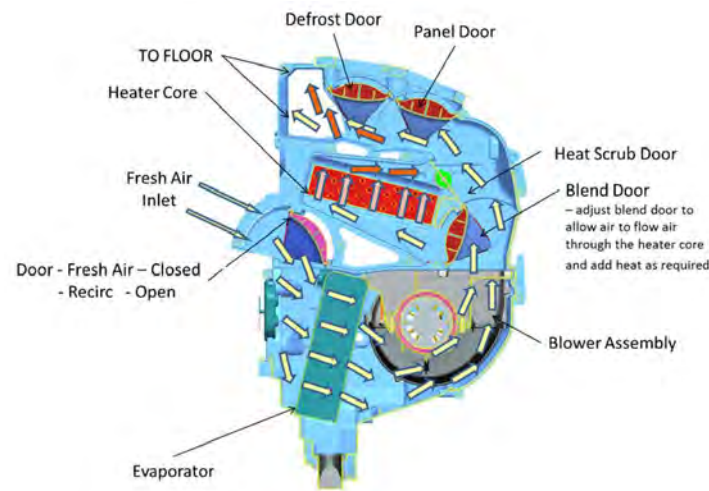

3E. FRESH AIR, FLOOR

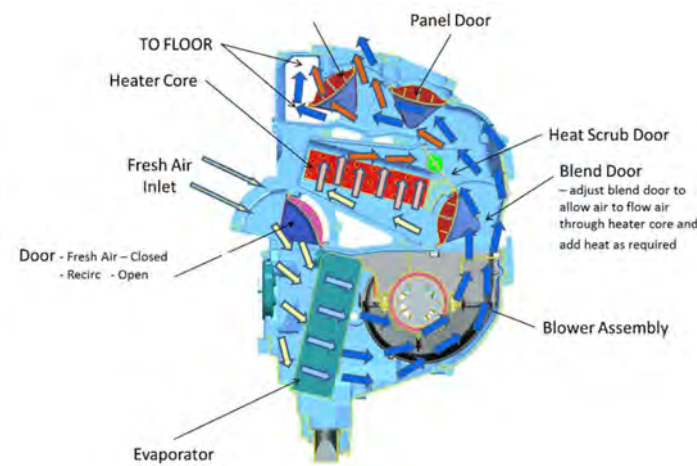

3F. FRESH AIR, DEFROST/FLOOR

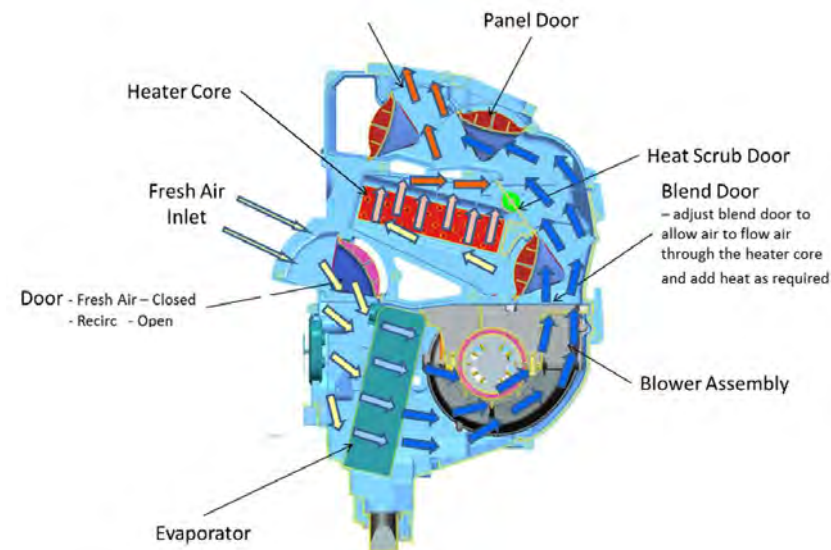

3G. FRESH AIR, DEFROST

Air Distribution (Air Conditioning)

Figure 3A illustrates the system airflow when operating in the MAX A/C mode. In this mode, the fresh/recirculated air door is in the recirculated position. Recirculated air (REC), from the cab, enters the HVAC unit through the recirculation filters, located on each side of the HVAC unit. The air is pulled by the blower assembly through the evaporator core and is pushed through the rest of the HVAC unit. The temperature blend air door diverts air around the heater core for full AC operation. Although the temperature control is operational while in the A/C modes, the temperature control is generally set to direct all the air around the heater core. The air proceeds to the mode door area which directs all of the air to the panel vents.

Figure 3B illustrates the system airflow when operating in the NORM A/C mode. In the NORM A/C mode, the fresh/recirculated air door is in the fresh air position. Fresh outside air enters the top of the fresh air module via an air duct, which is part of the cowl drain tray. The remainder of NORM A/C operation is identical to MAX A/C operation

Figure 3C illustrates the system airflow when operating in the Bi-Level A/C mode. The Bi-Level A/C mode operation is identical to NORM A/C operation; except, the mode doors direct the output air to both the floor ducts, and the panel vents.

Air Distribution (Heating & Ventilation)

Figure 3D illustrates the system airflow when operating in the Heat & Vent modes. In this mode, the fresh/recirculate air door is in the fresh air position. Fresh outside air enters the top of the fresh air module via an air duct, which is part of the cowl drain tray. The air is pulled into the HVAC unit, through the evaporator core, by the dual scroll blower assembly. The blower then pushes the air through the remainder of the HVAC unit. The temperature blend air door directs air either through the heater core or past it depending on the temperature selected for the outlet air. The temperature blended air proceeds to the mode doors where all of the air is directed to the panel vents. All of the air can bypassing the heater core if the temperature control is set at full cold. (The AC button in the control panel is disengaged at this point)

Figure 3E illustrates the system airflow when operating in the Heat and Vent Floor mode. The Heat and Vent Floor mode is identical to the Heat and Vent mode; except the mode doors direct all of the output air to the floor ducts. Figure 4D shows all air diverted through heater core (temperature control set to hot, full cw).
Air Distribution (Defrost)

Figure 3F illustrates the system airflow when operating in the Bi-Level Defrost/Heat mode. In the Bi-Level Defrost/Heat mode the fresh/recirculate air door is in the fresh air position. Fresh outside air enters the top of the fresh air module which is part of the cowl drain tray. The air is pulled into the unit, through the evaporator core, by the dual croll blower assembly. The blower then pushes the air through the remainder of the HVAC module. The temperature blend air door diverts air either through the heater core or past it depending on the temperature selected for the outlet air. The air proceeds to the mode doors where the doors direct the output air to both the defrost duct and the floor ducts.

Figure 3G illustrates the system airflow when operating in the Defrost mode. The Defrost mode is identical to the Bi-Level Defrost/Heat mode; except, the mode doors direct all of the output air to the defrost ducts.

2.2 MAIN COMPONENTS

Thermostatic Expansion Valve (TXV)

The thermostatic expansion valve (TXV) regulates the amount of liquid refrigerant that enters the evaporator. The TXV is connected to both the input and output lines of the evaporator core. By sensing the temperature of the refrigerant at the output of the evaporator, the valve determines the amount of refrigerant needed to the evaporator to keep the evaporator operating within correct parameters.

Freeze Probe

The freeze probe is located in the fins of the evaporator, and is used to measure temperature so as to prevent the evaporator from freezing up. The probe is located in the coldest spot of the evaporator and never should be inserted anywhere else in the evaporator.

Motor Speed Resistor

The Motor Speed Resistor is mounted on the blower scroll housing located in the cab under the right side of the instrument panel. The Resistor establishes the blower speed based on the setting of the blower speed control knob. As the blower speed control is turned the voltage across the blower motor will increase.

Recirculation Filter

The recirculation filters are installed in front of the recirculation inlets, on both sides of the HVAC unit. The recirculation filters trap particles during recirculation mode that could damage or reduce the performance of any of the HVAC unit components.

Heater Core

The heater core is a heating assembly made of copper tube and aluminum construction, with inlet and outlet fittings for connecting the heater hoses from the engine cooling system. The inlet and outlet fittings protrude from the HVAC unit. Engine coolant flows through the heater core at all times. The temperature of the air output by the heating/air conditioning system is determined by regulating more or less of the input air through the heater core. The heater core is serviced from inside the vehicle.

Blower Assembly

The blower assembly is located in the blower scroll housing. The blower assembly consists of a permanent magnet motor and cage style blower wheel both housed in a housing assembly designed to maximize the airflow and reduce noise. The motor speed is controlled by the left knob on the HVAC control panel on the instrument panel. The blower provides air circulation through the heater core and evaporator, and delivery of the treated air throughout the vehicle interior.

Evaporator Core

The evaporator core is a cooling assembly made of aluminum plate and fin construction, with "C-plate" block-style inlet and outlet fittings. Drain valves for both condensate and rain water are incorporated in the bottom of the HVAC unit below the evaporator.

3.0 HVAC ELECTRICAL SYSTEM OVERVIEW

General Operation of the HVAC Electrical System

The controls on the HVAC control head are used to adjust the cab air temperature mix, select the blower speed, and select the system operating mode, including recirculation or fresh air distribution of cab air. The blower speed is controlled by varying the amount of voltage applied to the blower motor. The temperature mix and system operating mode are selected by electronically controlling the actuators that position the airflow doors located in the interior module.

3. SYSTEM OPERATION

The operation of the Blend-Air system is based on standard automotive air conditioning and heating principles. NOTE – The following descriptions cover the 'heater/air conditioner' version of the system. Operation of the 'heater only' system (available on some models) is nearly identical, except all air conditioning information can be ignored.

Control Assembly

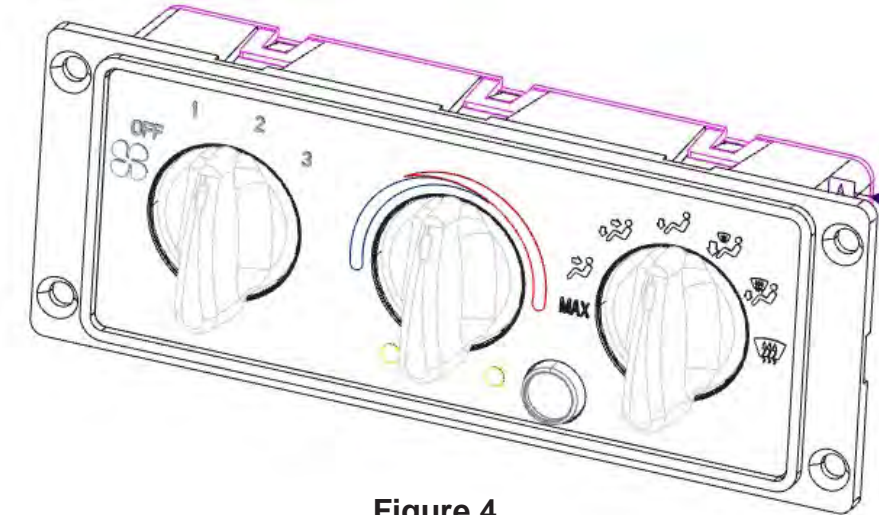

Figure 4
Control Panel

All major functions of the A/C-heater system are controlled from the control panel assembly. It consists of three rotary knobs, which electronically control the blower fan speed, the A/C compressor clutch, and the actuators that move the air doors used to control system air distribution and temperature.

3.1. BLOWER FAN SPEED CONTROL

This control regulates the amount of air provided to the vents in any mode you select. Turn the knob clockwise to increase fan speed. Turning the control to the OFF position will shut off the fan, but does not prevent outside air from entering the vehicle. Turning off the fan speed control prevents the A/C compressor from operating.

3.2. TEMPERATURE CONTROL







This control regulates the temperature of the air discharged from the vents. The blue area of the control indicates cooler temperatures while the red area indicates warmer temperatures. This control operates the blend door that determines what portion of the air flowing through the system is regulated through the heater core. As the temperature control is rotated clockwise, more air is regulated through the heater core, increasing the temperature of the air in the vehicle.

3.3. MODE CONTROL

This control selects the operating mode of the system (HEAT, VENT, DEFROST, and A/C) and controls which outlets are used to distribute the air. This is accomplished by electronically controlling the A/C compressor clutch, as well as three air doors located in the in-cab interior module.

3.4 AIR DISTRIBUTION

The air conditioning settings are indicated by icons with snowflakes.

Table 1 Air Distribution Chart					
Control Knob Position		Air Flow			
Air Conditioning Systems	Heater Only Systems	Panel	Floor	Windshield	
MAX A/C	MAX	N/A	100%		
NORM A/C		N/A	100%		
BI-LEVEL		N/A	75%	25%	
FLOOR		N/A		100%	
MIX (1)		N/A		60%	40%
MIX (2)		N/A		40%	60%
DEFROST		N/A			100%

MAX Air Conditioning Mode

In this mode, all airflow is directed to the panel air outlets and the air is recirculated inside the vehicle. In the MAX A/C mode, the fresh/recirculate air door is in the recirculate position. Use this mode to block out any outside odors, smoke, or dust and to cool the interior rapidly upon initial startup.

NORM Air Conditioning Mode

In this mode, all airflow is directed to the panel air outlets. Fresh (outside) air is used to cool the vehicle in this mode.

Bi-Level Air Conditioning Mode

In this mode, 75% of the airflow is directed to the panel air outlets, 25% of the airflow is directed to the floor air outlets, and fresh (outside) air is circulated inside the vehicle.

Floor Mode

In this mode, all airflow is directed to the floor air outlets and fresh (outside) air is circulated inside the vehicle.

Mix Mode

In this mode, 50% of the airflow is directed to the defrost outlets and side demist air outlets, 50% of the airflow is directed to the floor air outlets, and fresh (outside) air is circulated inside the vehicle.

Defrost

In this mode, all of the airflow is directed to the defrost outlets and side demist air outlets, and fresh (outside) air is circulated inside the vehicle.

4.0 COMPONENT SERVICING

4.1. FREEZE PROBE

Freeze Probe-Removal

1. Cut wires ties as necessary and disconnect freeze probe electrical connector.
2. Press grommet through interior module with electrical connector.
3. Gently pull the freeze probe out of face of the evaporator.

Freeze Probe – Installation

1. Gently push the freeze probe into the face of the evaporator to the depth noted during removal.
 2. Pull electrical connector through interior module with grommet. Ensure grommet seats properly in interior module.
 3. Connect freeze probe electrical connector and secure with wire ties as necessary.
 4. Install blower scroll housing. Refer to BLOWER SCROLL HOUSING.
- 4.2 THERMOSTATIC EXPANSION VALVE (TXV)

Thermostatic Expansion Valve (TXV) – Removal

1. Discharge A/C system. Refer to DISCHARGING THE SYSTEM (RECYCLE MODE).
2. Remove filter-drier. Refer to FILTER-DRIER.
3. With front locking plate removed from expansion valve, remove two Allen head screws from expansion valve body. Remove and retain rear locking plate.
4. Remove expansion valve (TXV).
5. With front locking plate removed from expansion valve, remove two Allen head screws from expansion valve body. Remove and retain rear locking plate.
6. Remove expansion valve (TXV).

Thermostatic Expansion Valve (TXV) – Installation

1. If A/C system is to be flushed, perform that operation before reassembling the system. Refer to FLUSHING AND PURGING THE AIR CONDITIONING SYSTEM.

NOTE – During installation always lubricate O-rings on fittings with mineral-based oil.

2. Ensure that new lubricated O-rings are installed on all lines being connected to expansion valve.
3. Position rear locking plate over evaporator inlet and outlet lines. (Figure 25).
4. Install expansion valve on rear locking plate over the inlet and outlet lines and secure expansion valve with two Allen head screws (Figure 25).
5. Install filter-drier. Refer to FILTER-DRIER.
6. Recharge A/C system. Refer to:
 - a. AIR CONDITIONING OIL AND DYE INJECTION EQUIPMENT
 - b. OIL FILL GUIDELINES
 - c. AUTOMATIC MODE

A/C Charge Weight is 1.87 LBS

4.3 INTERIOR MODULE TRIM COVER

The interior module trim cover must be removed prior to removing any of the HVAC components located under the right side of the instrument panel (IP)...

Interior Module Trim Cover – Removal

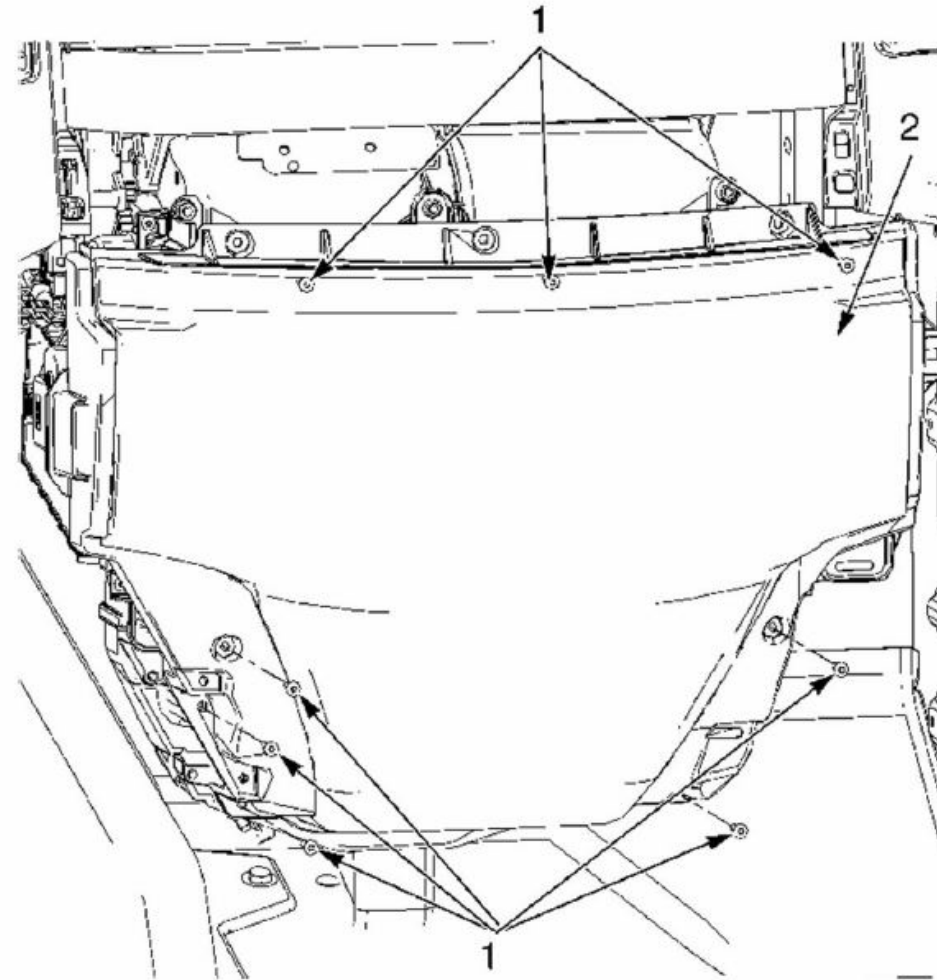

1. Remove eight screws from interior module trim cover.
2. Remove cover by pulling it straight back.

Interior Module Trim Cover – Installation

1. Secure interior module trim cover to interior module with eight screws
2. Install all additional trim panels removed to gain access to interior module trim cover.
3. Install fuse panel cover by inserting two tabs at bottom of cover into sockets in IP; then press top of cover toward IP to engage spring clips.

4.4 FRESH/RECIRCULATE DOOR ACTUATOR

The interior module trim cover must be removed prior to removing any of the HVAC components located under the right side of the instrument panel (IP). Removal and installation of the interior module trim cover may require the removal of other trim panels. The panels that must be removed vary by vehicle model and trim level. Refer to the appropriate CAB section(s) in GROUP 16 of the Master Service Manual for additional procedures.

Fresh/Recirculate Door Actuator – Removal

1. Remove interior module. Refer to INTERIOR MODULE TRIM COVER

NOTE:
Actuators shown may be different from what is used on HVAC unit. Locations, screws and a connection points are common

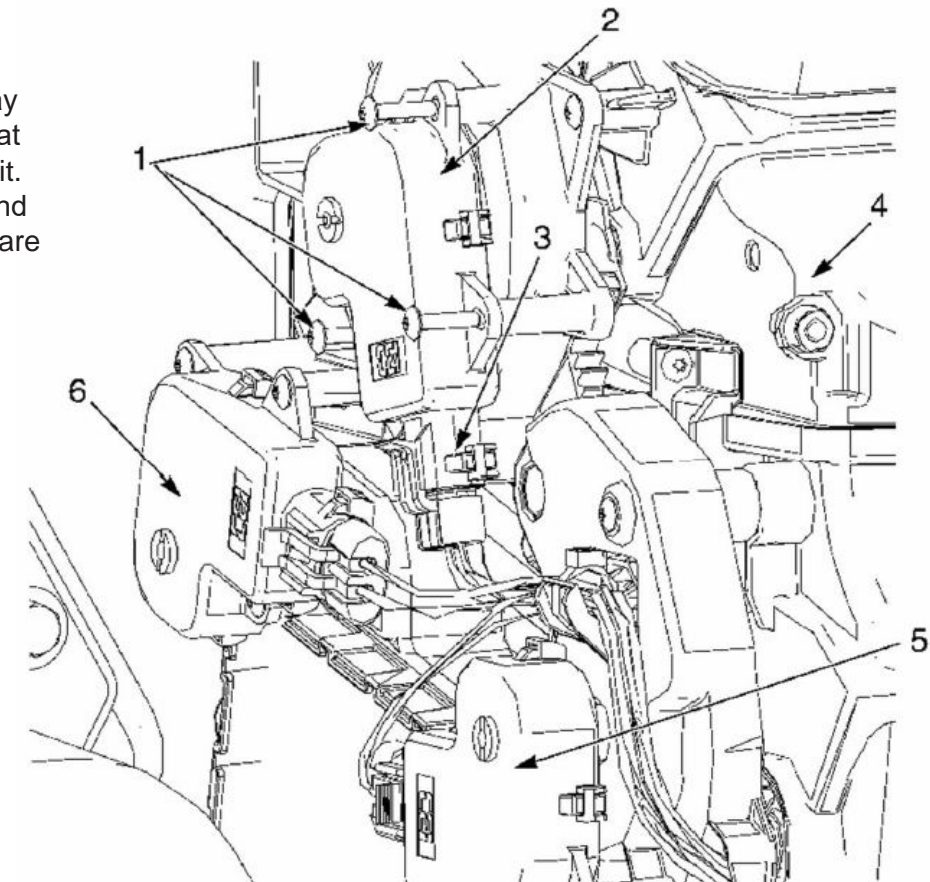

1. Screw (3 per actuator)	4. HVAC Module
2. Mode Door Actuator	5. Blend Air Door Actuator
3. Connector area	6. Fresh/Recirc Door Actuator

Figure 6 Fresh/Recir., Mode and Blend Door Actuators

1. Disconnect electrical connector from fresh/recirculate door actuator.
2. Remove three screws from fresh/recirculate door actuator and remove fresh/recirculate door actuator.

Fresh/Recirculate Door Actuator – Installation

1. Secure fresh/recirculate door actuator to interior module using three screws (Figure 29, Items 2, 3 and 6).
2. Connect electrical connector to fresh/recirculate door actuator (Figure 29, Items 2 and 5).
3. Install interior module. Refer to INTERIOR MODULE TRIM COVER

4.5 BLEND DOOR ACTUATOR

Blend Door Actuator – Removal

1. Remove interior module trim cover. Refer to INTERIOR MODULE TRIM COVER.
2. Disconnect electrical connector from blend door actuator.
3. Remove three screws from blend door actuator and remove blend door actuator.

Blend Door Actuator – Installation

1. Install blend door actuator by rotating door until flats on door shaft align with blend door actuator drive collar, if possible, then carefully slip the blend door actuator onto end of door shaft so that mounting holes are properly aligned.
2. Secure blend door actuator to interior module using three screws (Figure 30, Items 2, 3, and 4).
3. Connect electrical connector to blend door actuator (Figure 30, Items 2 and 5).
4. Install interior module trim cover. Refer to INTERIOR MODULE TRIM COVER.

4.6 MODE DOOR ACTUATOR.

Mode Door Actuator – Removal

1. Remove interior module. Refer to INTERIOR MODULE TRIM COVER
2. Disconnect electrical connector from mode door actuator.
3. Remove three screws securing mode door actuator to interior module, and pull mode door actuator straight off of mode door shaft.

4.7 RECIRCULATION FILTERS

Recirculation Filters – Removal

1. Remove bolt from duct trim panel.
2. Carefully pull duct trim panel away from HVAC unit and remove duct trim panel.
3. Remove interior module trim cover. Refer to INTERIOR MODULE TRIM COVER.

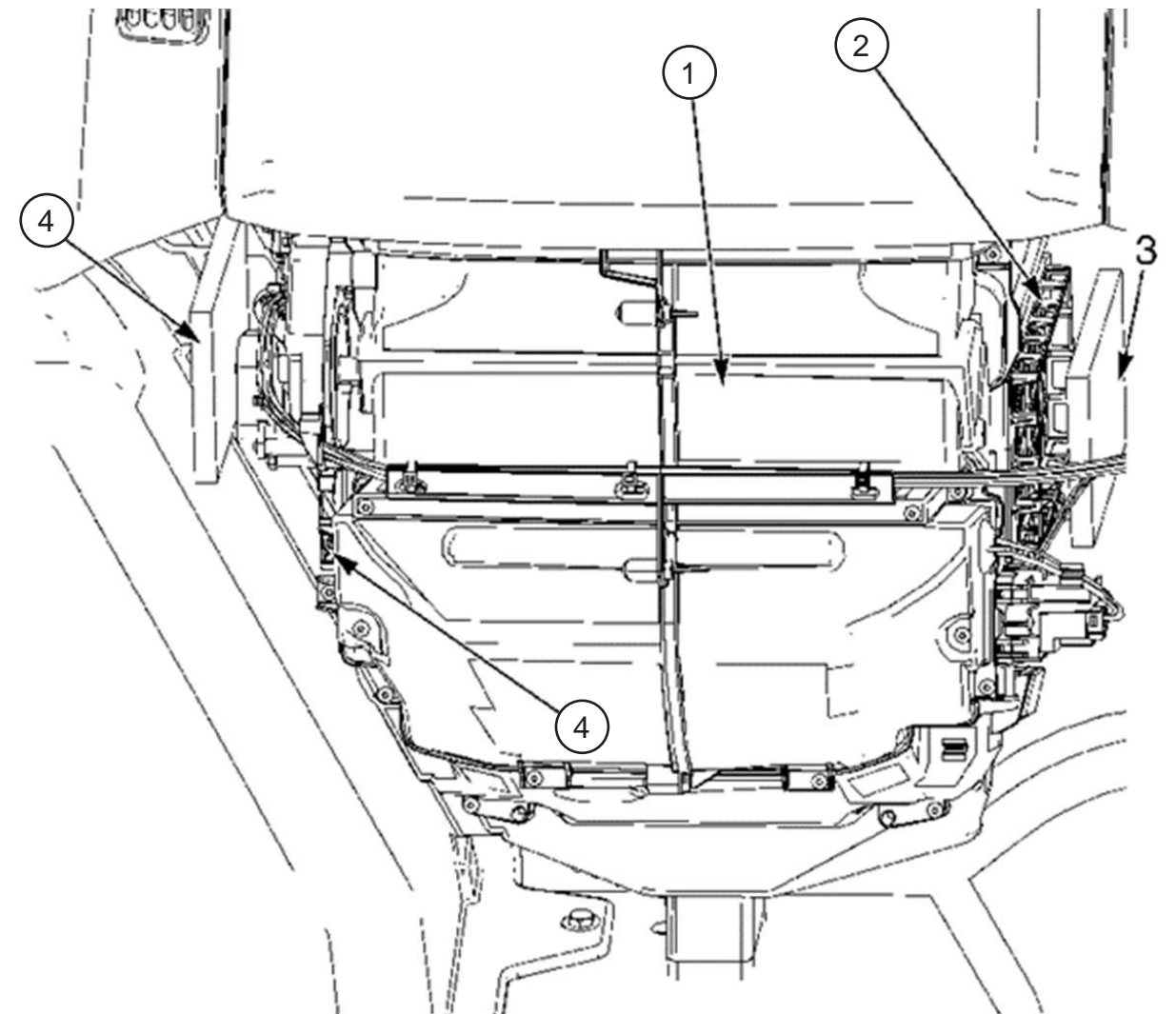

1. HVAC Unit	3. Recirc filter right side
2. Recirc filter holder	4. Recirc filter left side

1. Carefully pull right recirculation filter out of recirculation filter holder.
2. Carefully pull left recirculation filter out of recirculation filter holder.

Recirculation Filters – Installation

1. Carefully press left recirculation filter into recirculation filter holder, making sure not to damage filter and ensure recirculation filter goes all the way in, so recirculation filter cage secures filter in place (Figure Items 2 and 4).
2. Carefully press right recirculation filter into recirculation filter cage, making sure not to damage filter and ensure recirculation filter goes all the way in, so recirculation filter cage secures filter in place (Items 2 and 3).
3. Install interior module trim cover. Refer to INTERIOR MODULE TRIM COVER.

4.8 Motor Speed Control (Resistor)

Resistor Assembly – Removal

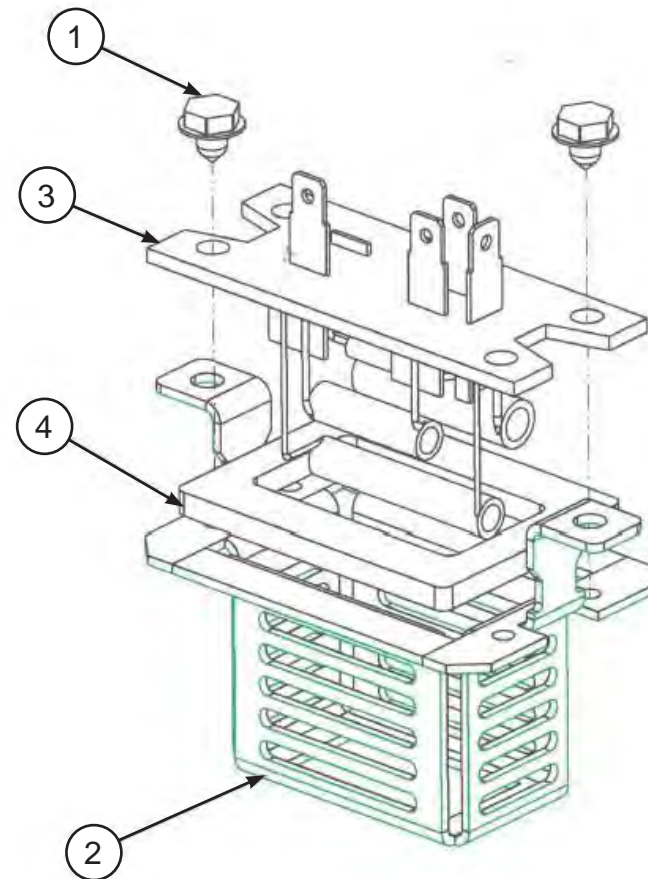

1. Screw	3. Resistor
2. Resistor Cage	4. Gasket

1. Locate Resistor/Cage Assy on interior module and disconnect the electrical connector.
2. Remove two screws Resistor/Cage Assy
3. Remove the Resistor/Cage Assy from the HVAC unit

Resistor Assembly – Installation

1. Install resistor/cage assy to interior module and secure with two screws.
2. Connect electrical connector to resistor

4.9 BLOWER ASSEMBLY

Blower Assembly – Removal

1. Remove blower scroll housing. Refer to BLOWER SCROLL HOUSING.

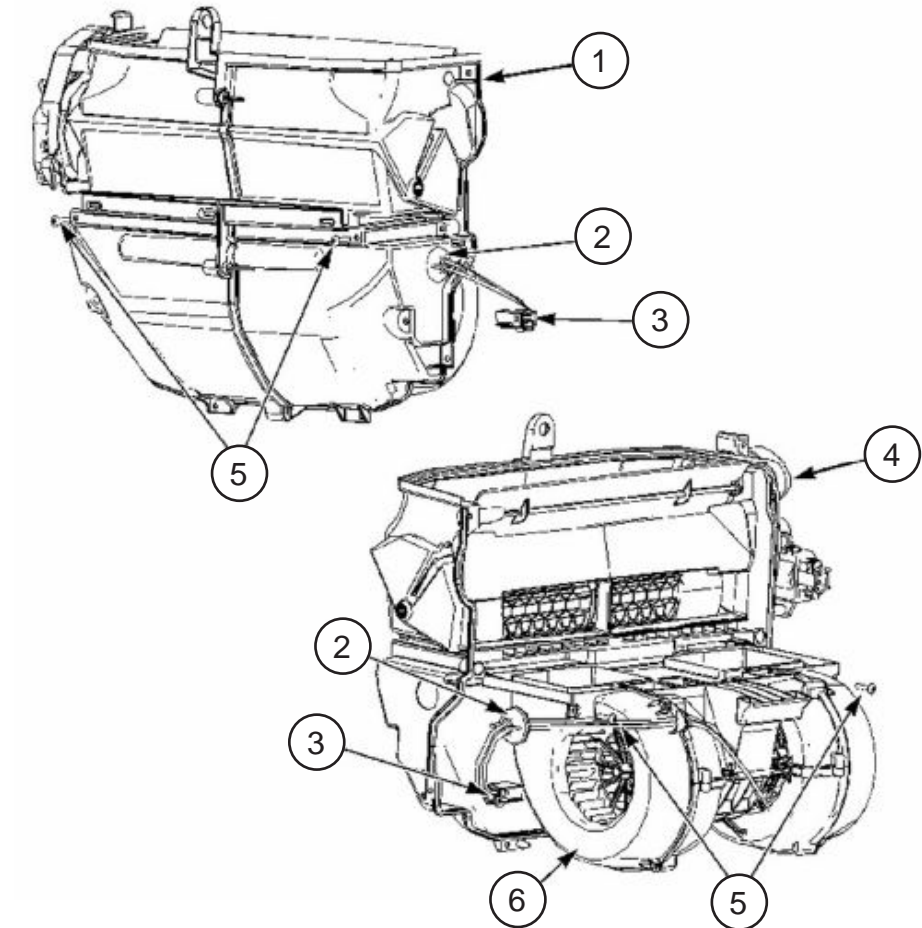

1. Blower Scroll Housing (RH)	4. Blower Scroll Housing (LH)
2. Grommet	5. Screw
3. Electrical Connector	6. Blower Housing

Blower Assembly

2. Remove two screws from front of blower scroll housing.
3. Carefully pull grommet and electrical connector through blower scroll housing.
4. Remove two screws from rear of blower scroll housing and remove blower assembly.

Blower Assembly – Installation

1. Insert blower assembly into blower scroll housing and secure with four screws (Items 1, 4, 5, and 6).
2. Pull electrical connector through blower scroll housing (Items 1, 3, and 4).
3. Secure grommet in blower scroll housing (Items 1 and 2).
4. Install blower scroll housing. Refer to BLOWER SCROLL HOUSING.

4.10 HEATER CORE

Access to the heater hoses may require the removal of other assemblies.

Heater Core – Removal

1. Drain engine coolant from heater core and connected heater lines.

NOTE – Before removing heater hoses in the following step, label hoses to ensure correct installation.
 2. Remove two spring clamps and disconnect both heater hoses from heater core tubes on engine side of cowl.

3. From inside cab, remove blower scroll housing. Refer to BLOWER SCROLL HOUSING.

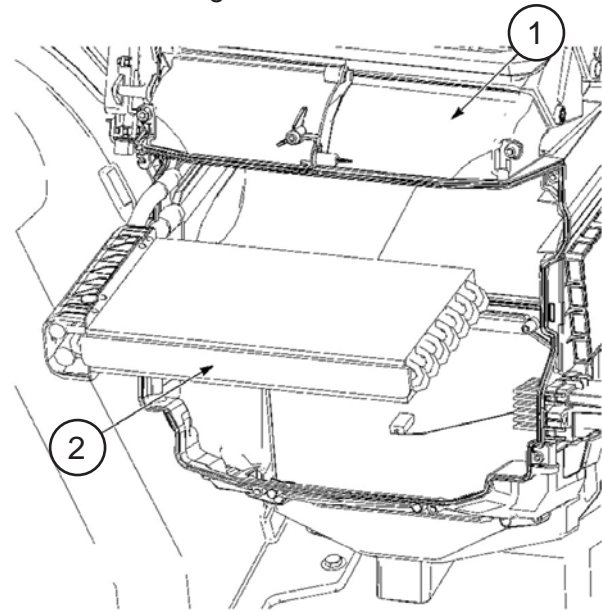

1. HVAC Unit	2. Heater Core
--------------	----------------

NOTE – The heater core is mounted at a slight angle and therefore retains a small amount of coolant in the core. Be careful to keep the core in an upright position until the coolant can be drained.
 4. Pull heater core out of interior module.

Heater Core – Installation

NOTE – In the following step, ensure that the interior module seal that surrounds the heater core tubes does not become dislodged while installing the heater core.

1. From inside cab, carefully position heater core in interior module so that tube ends of core protrude through dash panel seal (Figure 49).
2. Install blower scroll housing. Refer to BLOWER SCROLL HOUSING.

NOTE – In the following step, position the heater hose clamps to allow easy access for their next removal.

3. Install heater hoses and clamps.
4. Fill cooling system with coolant.

4.11 EVAPORATOR

A/C Charge Weight 1.87 LBS

Evaporator – Removal

1. Discharge A/C system.
2. Remove blower scroll housing. Refer to BLOWER SCROLL HOUSING.
3. Remove expansion valve. Refer to THERMOSTATIC EXPANSION VALVE (TXV).

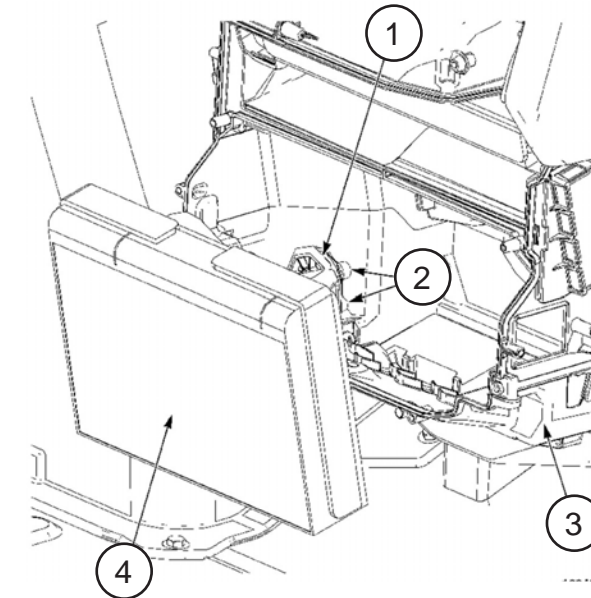

1. Grommet	3. HVAC Unit
2. Evaporator Tubes	4. Evaporator

Evaporator

4. Carefully press evaporator tube grommet through interior module housing. May be helpful to use a flat tip screwdriver to work grommet seal off.
5. Carefully maneuver evaporator out of interior module, using caution not to damage evaporator tubes or the evaporator itself.
6. Once evaporator is out of the interior module, remove the grommet from the evaporator tubes.

Evaporator – Installation

1. Install grommet onto evaporator tubes (Items 1 and 2).
2. Installation may require additional personnel to aid with grommet installation while the evaporator is being installed.
3. Lubrication may be required when installing the grommet.
4. Install evaporator into interior module, while guiding the evaporator tubes and grommet through outside the vehicle. Ensure grommet seats properly.
5. Install expansion valve. Refer to EXPANSION VALVE.
6. Install blower scroll housing. Refer to BLOWER SCROLL HOUSING

5.0 PARTS LIST

5.1 HVAC Unit Parts List

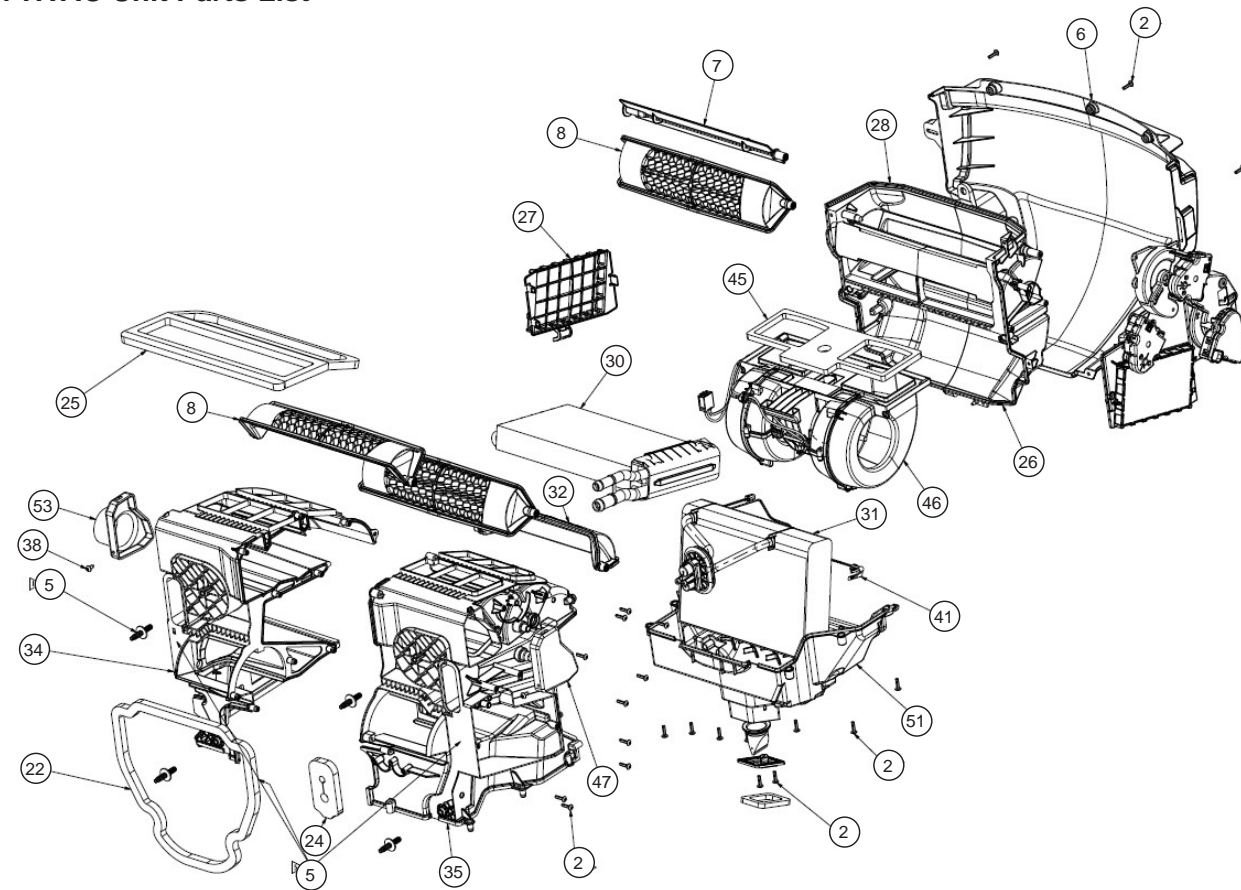

Recirc Components Details

Evaporator Components Details Only

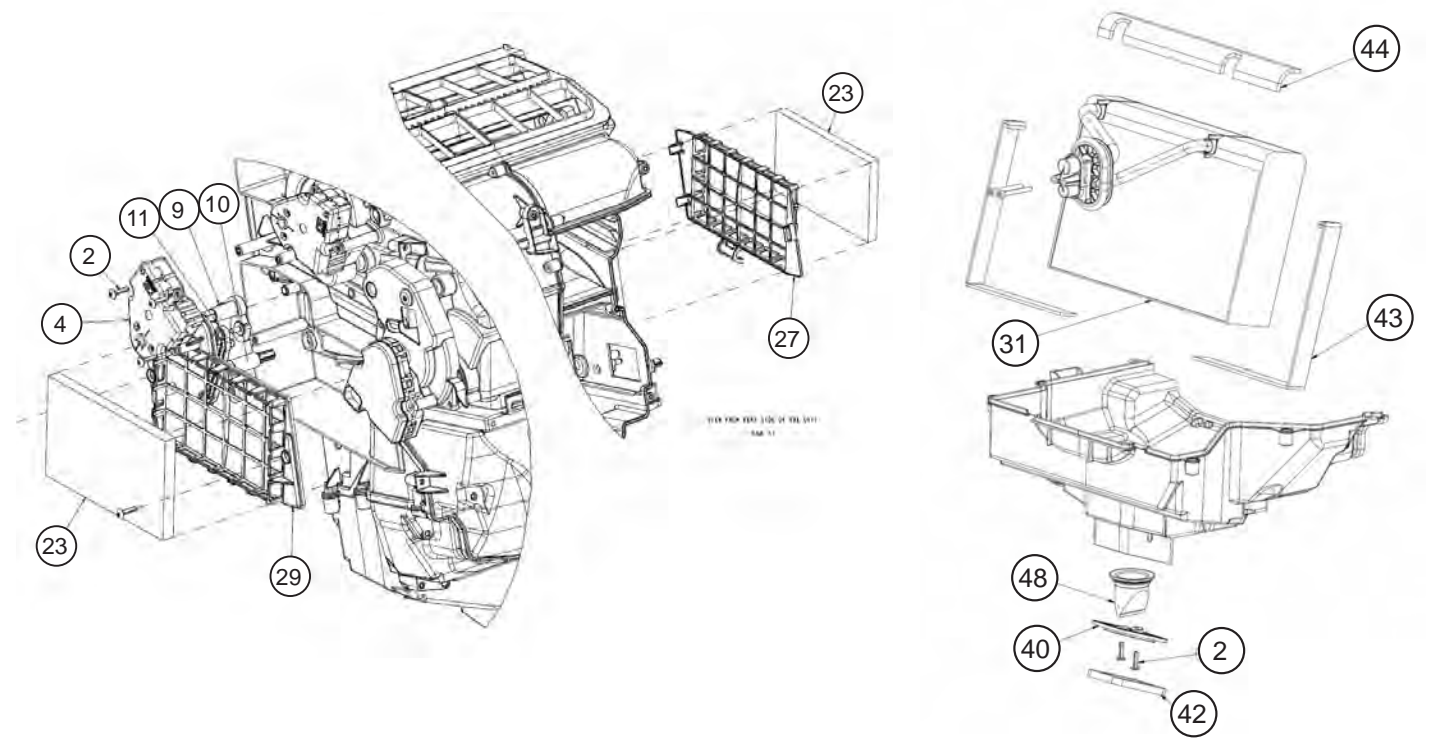

Actuator Components (Details Only)

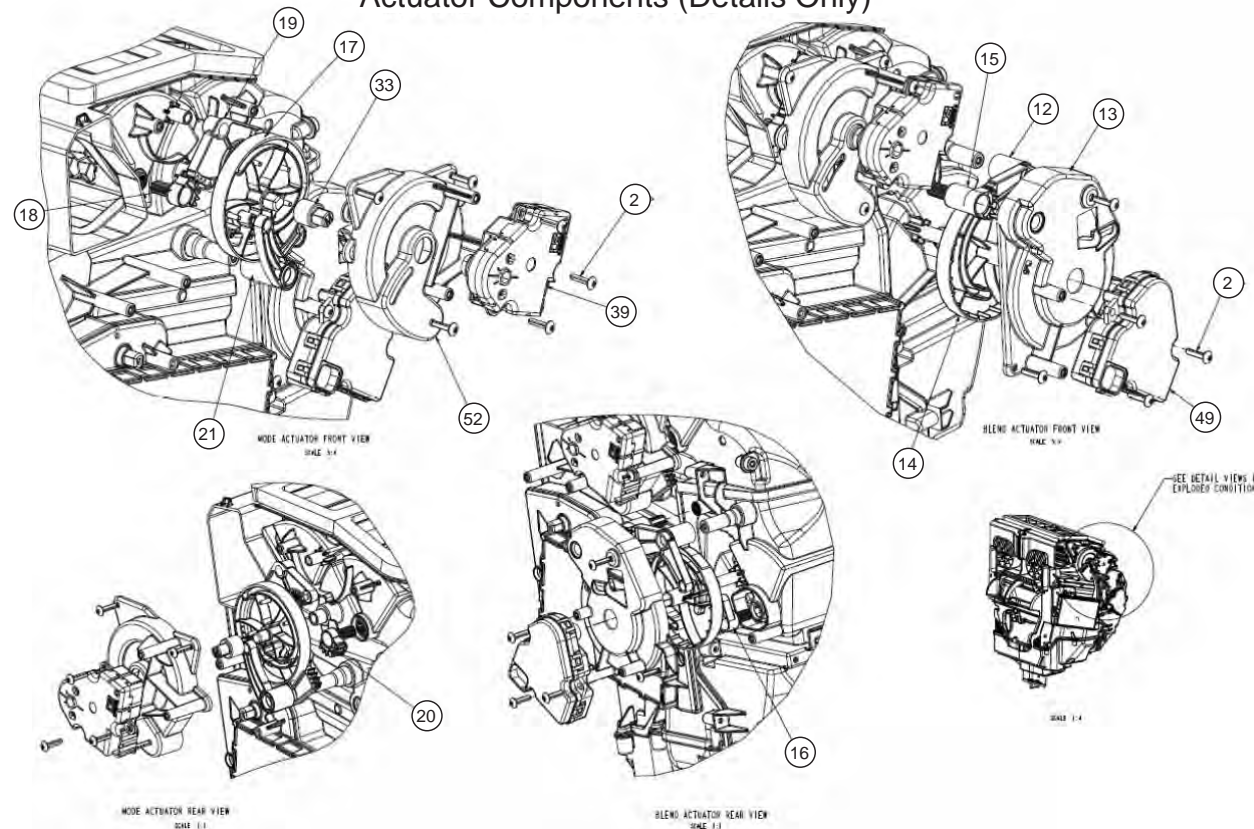

ITEM #	QTY	UNIT	Part #	DESCRIPTION
A	1	EA	1002885232	HVAC UNIT
4	1	EA	651258	ACTUATOR, FRESH AIR
6	1	EA	1000086969	COVER, REAR ACCESS
23	2	EA	1000103877	FILTER, RECIRCULATION
30	1	EA	1000123882	HEATER CORE
31	1	EA	1000132237	EVAPORATOR
33	1	EA	1000142470	ADAPTER, MODE CAM
37	1	EA	1000173204	RESISTOR, MOTOR SPEED
39	1	EA	1000291950	ACTUATOR, MODE
41	1	EA	1000337343	SENSOR, TEMPERATURE
46	1	EA	1000431297	BLOWER MOTOR
47	1	EA	1000435612	CAP FLOOR OB
48	1	EA	1000593040	ACTUATOR, BLEND
53	1	EA	1002883183	CAP FLOOR TRANSITION
54	1	EA	1002951345	HARNES, WIRING

5.2 Control Panel Parts



ITEM #	QTY	UNIT	Part #	DESCRIPTION
1	1	EA	49013205	CONTROL PANEL

5.3 WIRING DIAGRAM

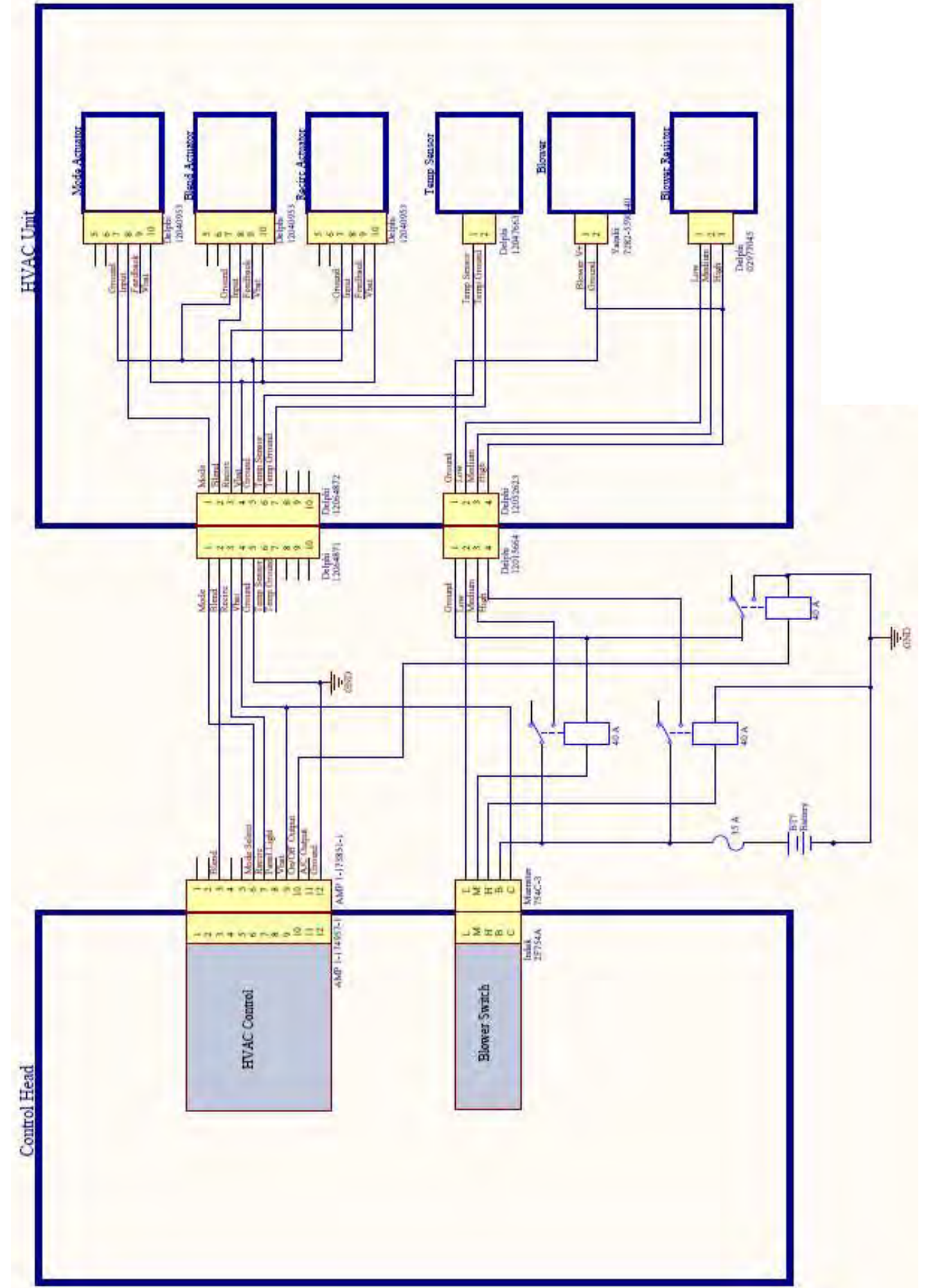



500 N. WARPOLE ST.

UPPER SANDUSKY, OH 43351

CUSTOMER SERVICE PHONE 877-876-7452

ROLL-UP DOOR PREVENTIVE MAINTENANCE CHECKLIST

⚠️ WARNING

The Counterbalance Spring is wound under High Tension. This High-Tension Counterbalance Spring can cause Severe Injury or Death. Only Qualified technicians should adjust this spring.

Use two winding bars that are 1/2" in diameter and 15" long on Single Spring Assembly and one winding bar that is 3/8" in diameter and 15" long on Dual Spring Assembly with TG-Winder. DO NOT USE bent winding bars, screwdrivers, or punches for spring winding.

⚠️ CAUTION

Read all instructions before starting Preventive Maintenance Checklist. Always maintain firm footing and control of tools.

Adjustments and repairs must be made by trained service personnel using proper tools and instructions.

DO NOT use the rear door and side door pull straps to support yourself when entering or exiting the vehicle. The strap can break or pull the door down on you.

Stand clear of the opening while the door is moving.

NOTICE

To prevent damage to the cargo or vehicle, be sure that the rear door is closed and latched before driving the vehicle.

NOTICE

LUBRICATION

Lubricate the Counterbalance Spring, Counterbalance Shaft Bearings, Rollers, Hinges, Top Fixtures, Bottom Roller Holders, and Locks liberally with Transglobal Lube. Do NOT use grease. Wipe dirt from track. Frequency of door maintenance will vary with climate conditions and door cleaning procedures. Doors which are steam cleaned will need lubricated more often. Doors on equipment operated in areas where road salts are used will require lock lubrication at closer intervals. Do NOT use any petroleum-based lubricant on rubber door seals.

TGS1000

ADVANTAGES

Long lasting, non-toxic, non-static, non-staining, non-conductive, contains no petroleum distillates, no silicones, no acids, no carcinogens, no halogens, and no allergens. Will not dry out, or wash off with water. Will not damage plastics, paints, metals, fiberglass, enamels, or neoprene seals. No petroleum smells. H- Registered for Food Processing Areas.

USES

Lubricate and protect locks, hinges, rollers, air tools, roll-up doors, lift gates, springs, chains, and bearings. Cutting oil for drilling and tapping. Penetrates and neutralizes rust on nuts, bolts, screws, equipment and motors. Cleans corrosion and oxidation off battery terminals and metals.



(See  for Lubrication points below.)

LUBRICATION OF END HINGES, 2-POINT CENTER CONTROL & END LATCHES

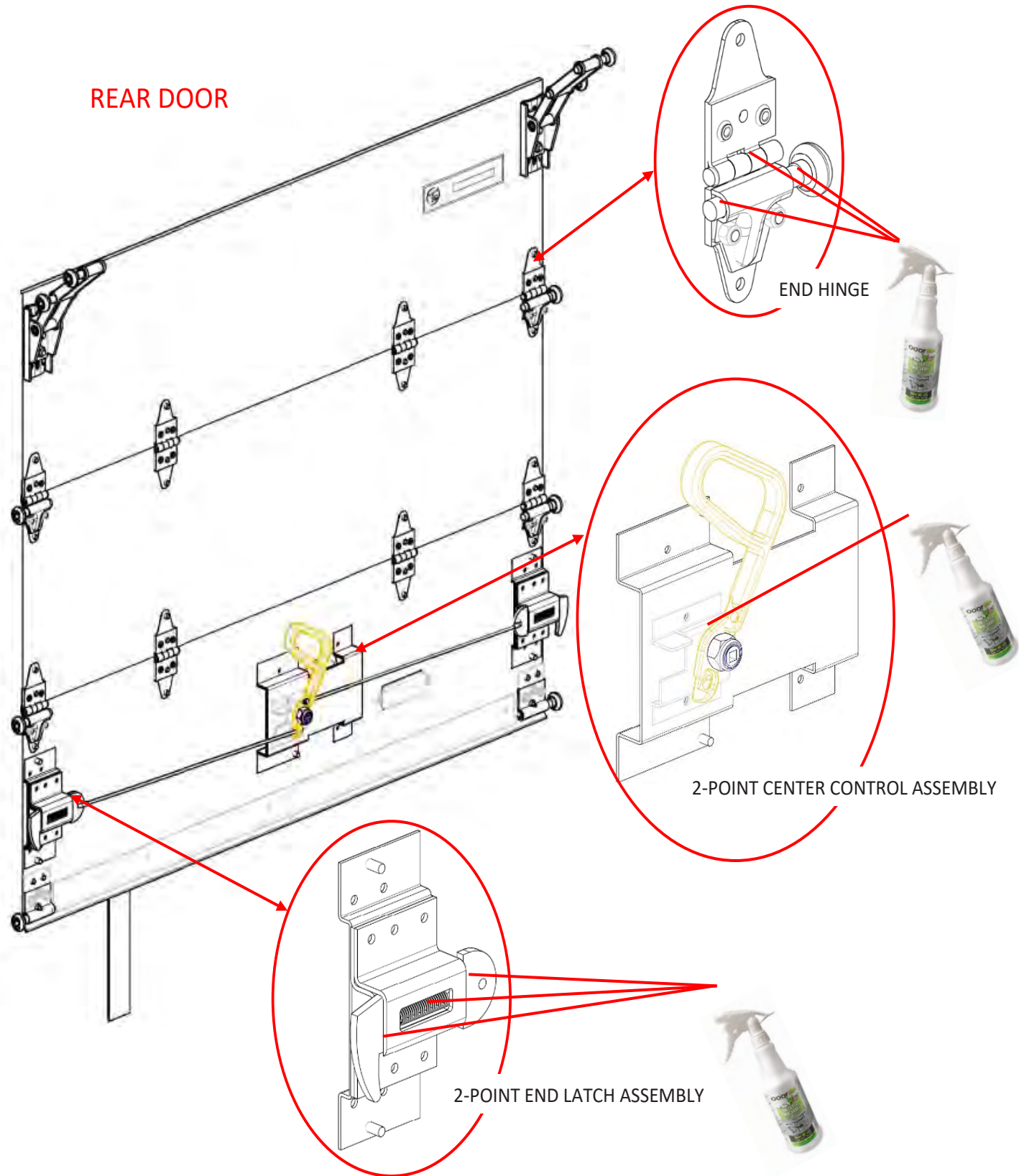

LUBRICATION OF TOP FIXTURE, CENTER HINGE & BOTTOM FIXTURE

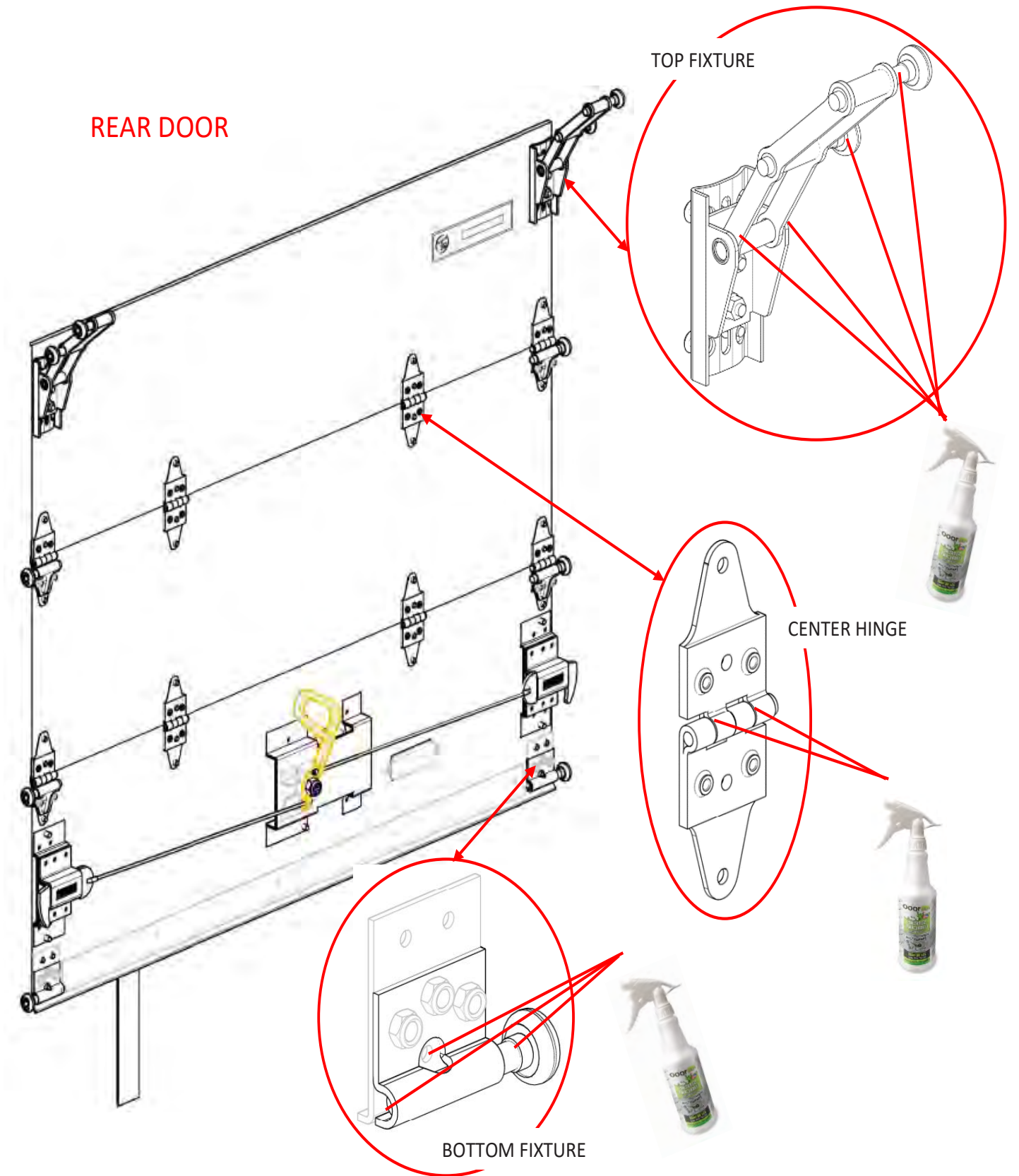

LUBRICATION OF TOP FIXTURE, CENTER HINGE & BOTTOM FIXTURE

LUBRICATION OF END HINGES, 2-POINT CENTER CONTROL & END LATCHES

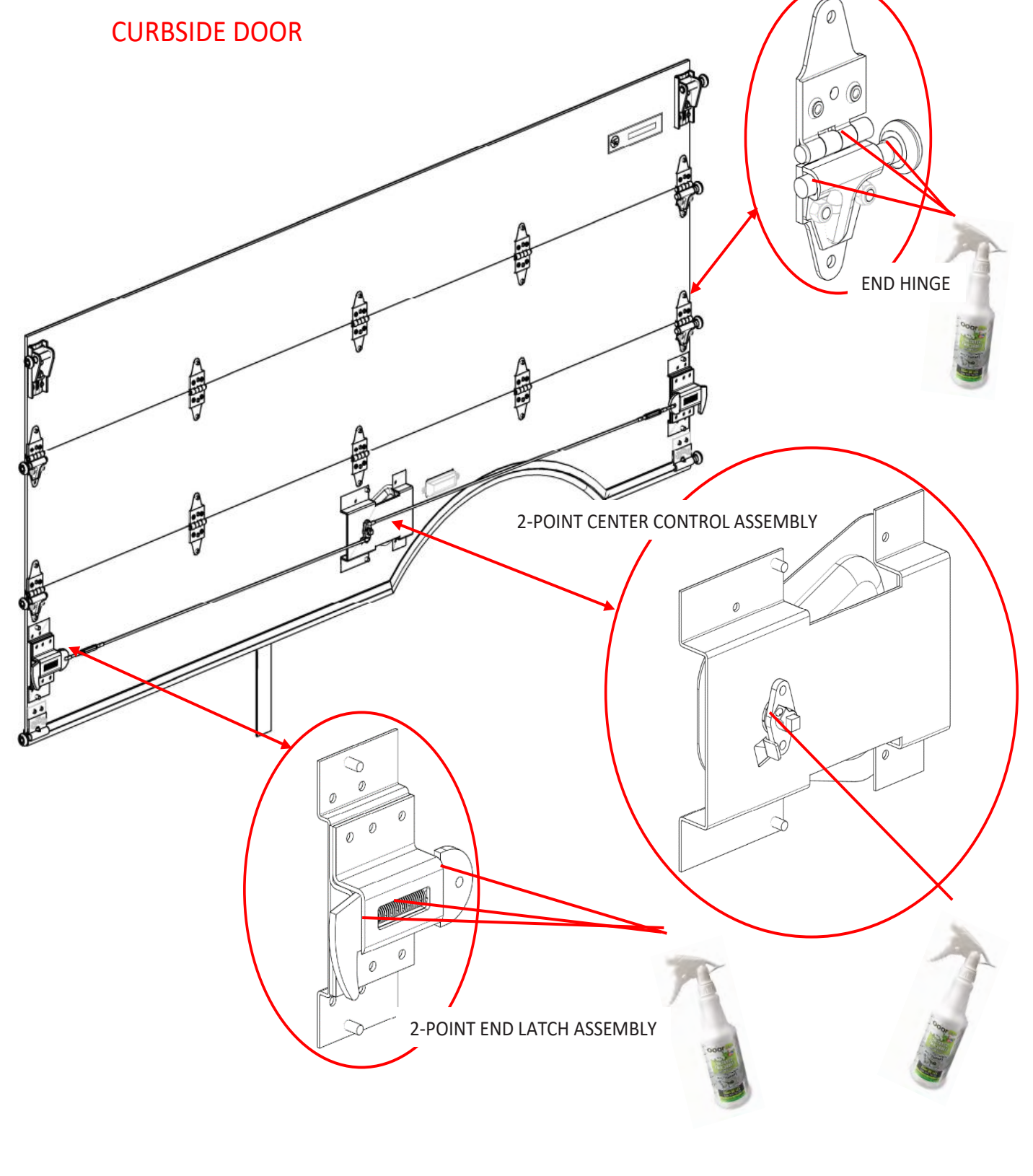
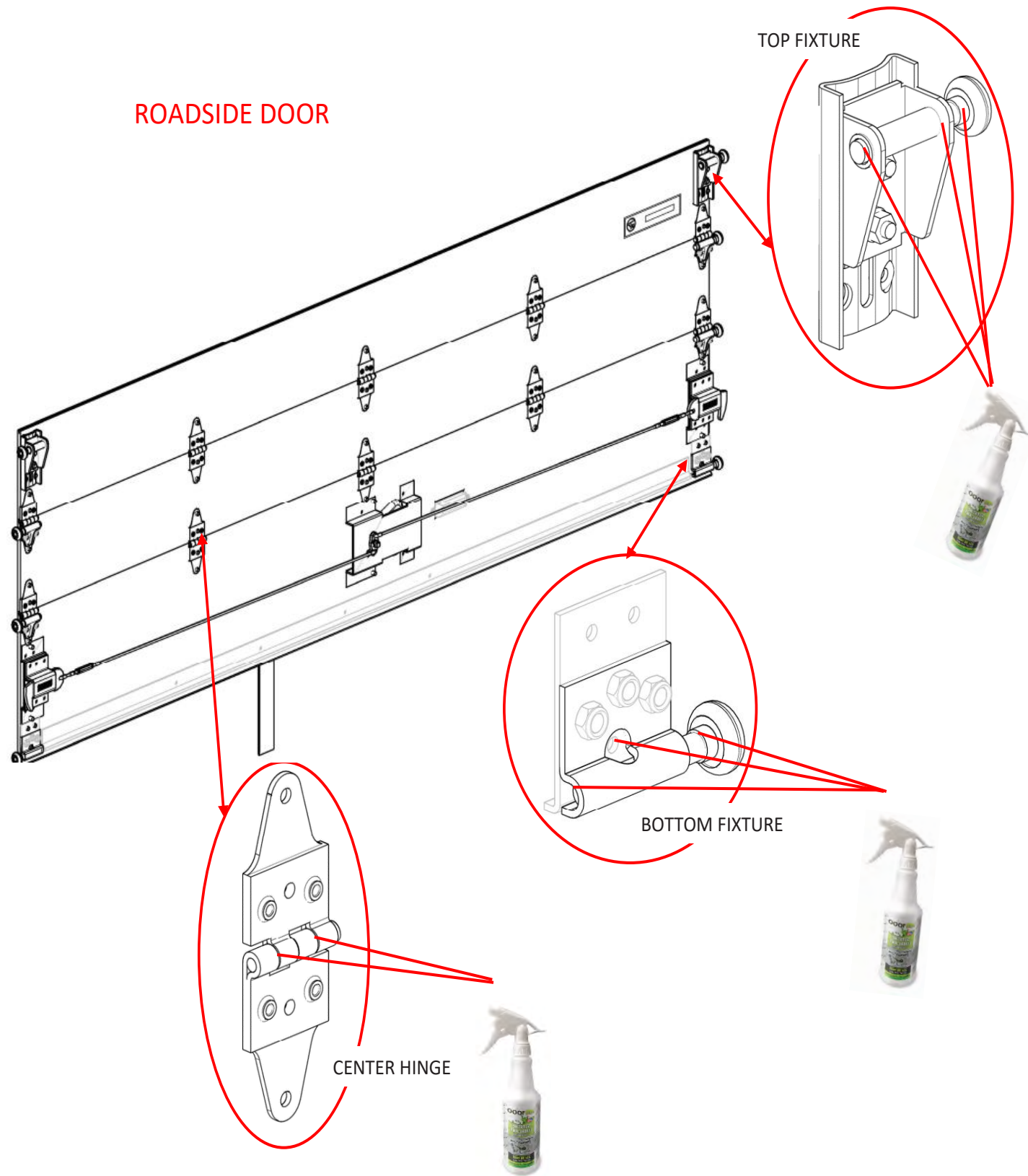

LUBRICATION OF TOP FIXTURE, CENTER HINGE & BOTTOM FIXTURE

CURBSIDE DOOR

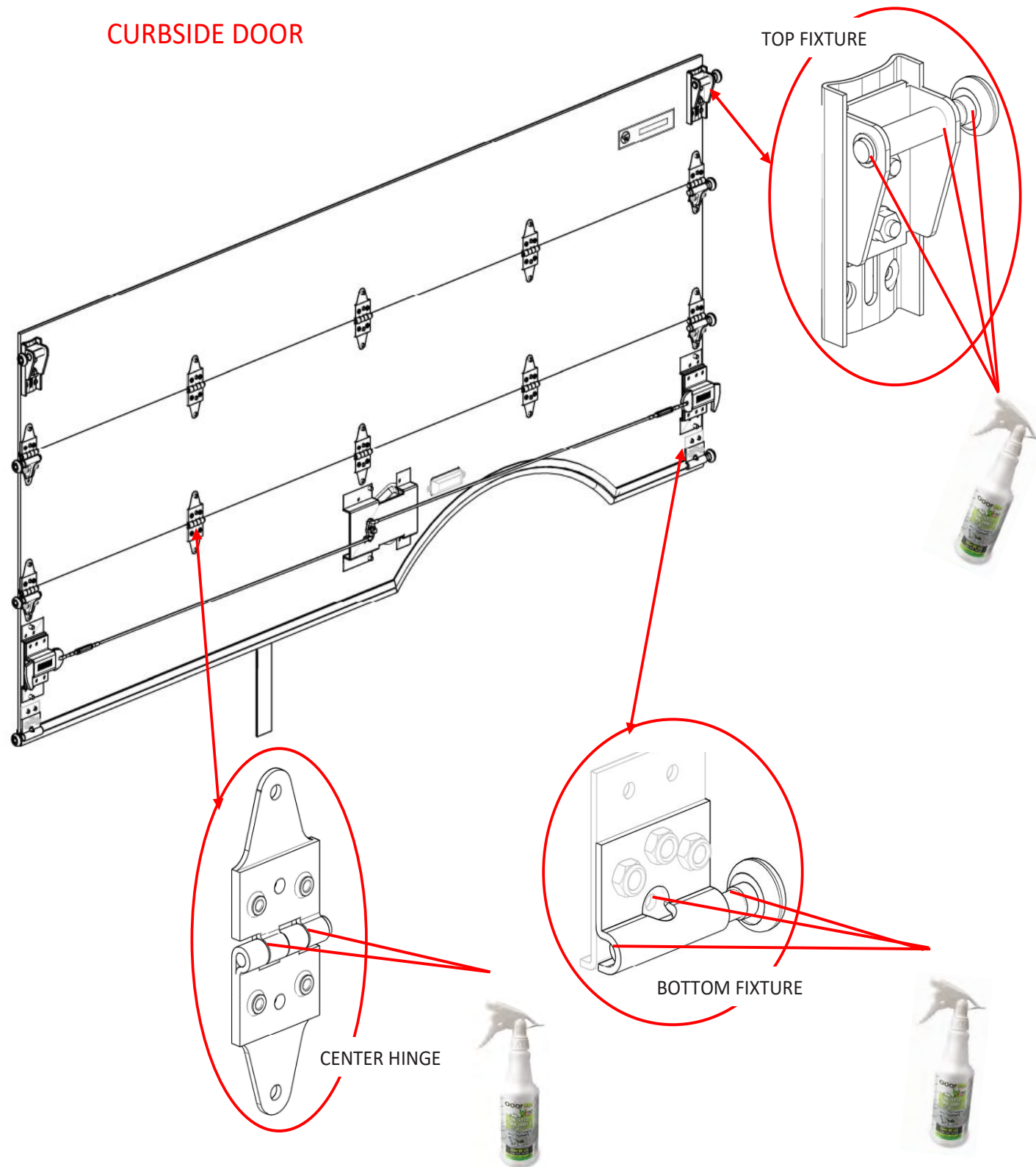

LUBRICATION OF SINGLE AND DUAL SPRING ASSEMBLIES

NOTICE

On single spring assemblies – lubricate spring along the entire length to prevent rusting.

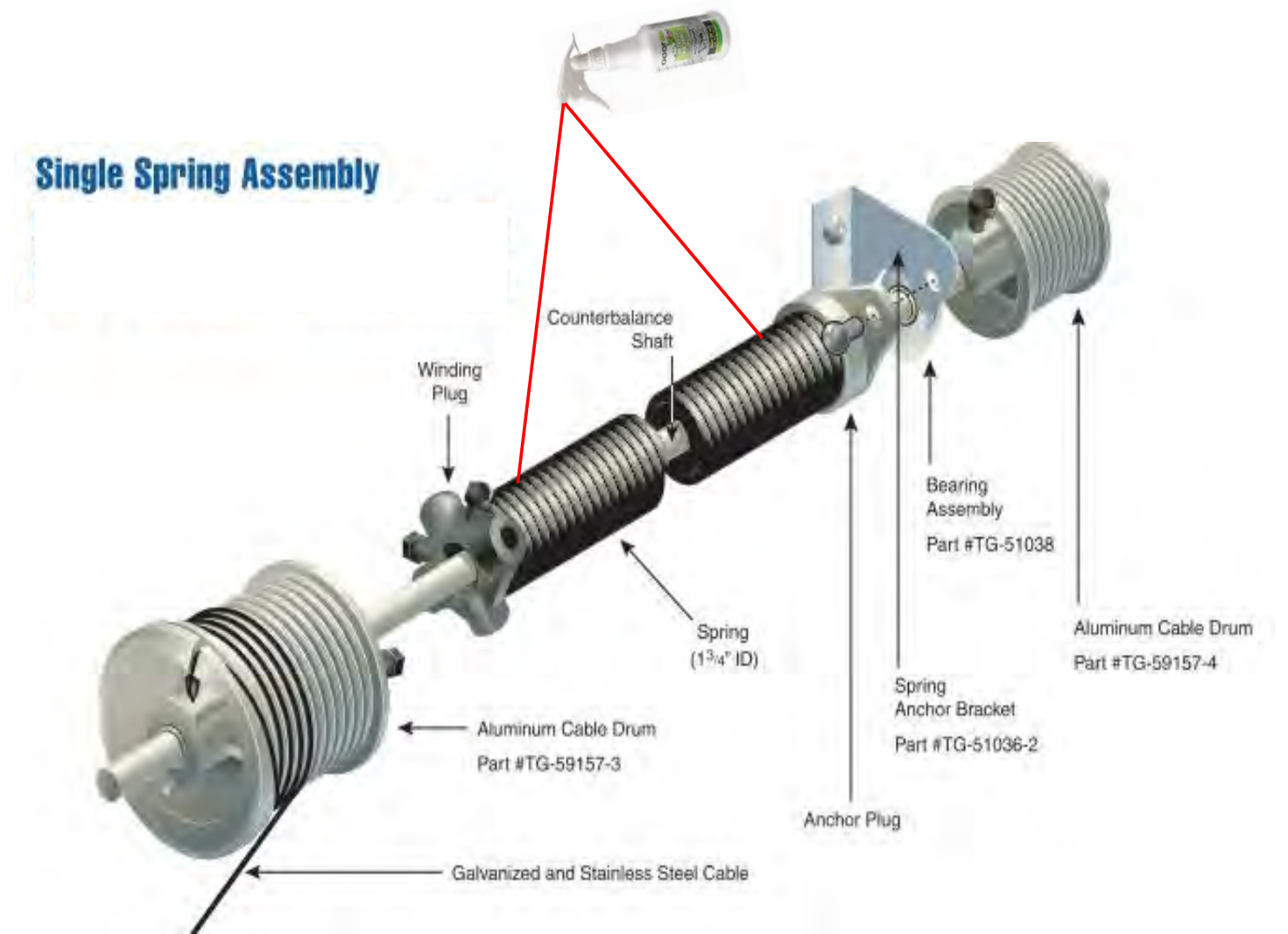

LUBRICATION OF SINGLE AND DUAL SPRING ASSEMBLIES

NOTICE

On dual spring assemblies – lubricate spring(s) along their entire length to prevent rusting.

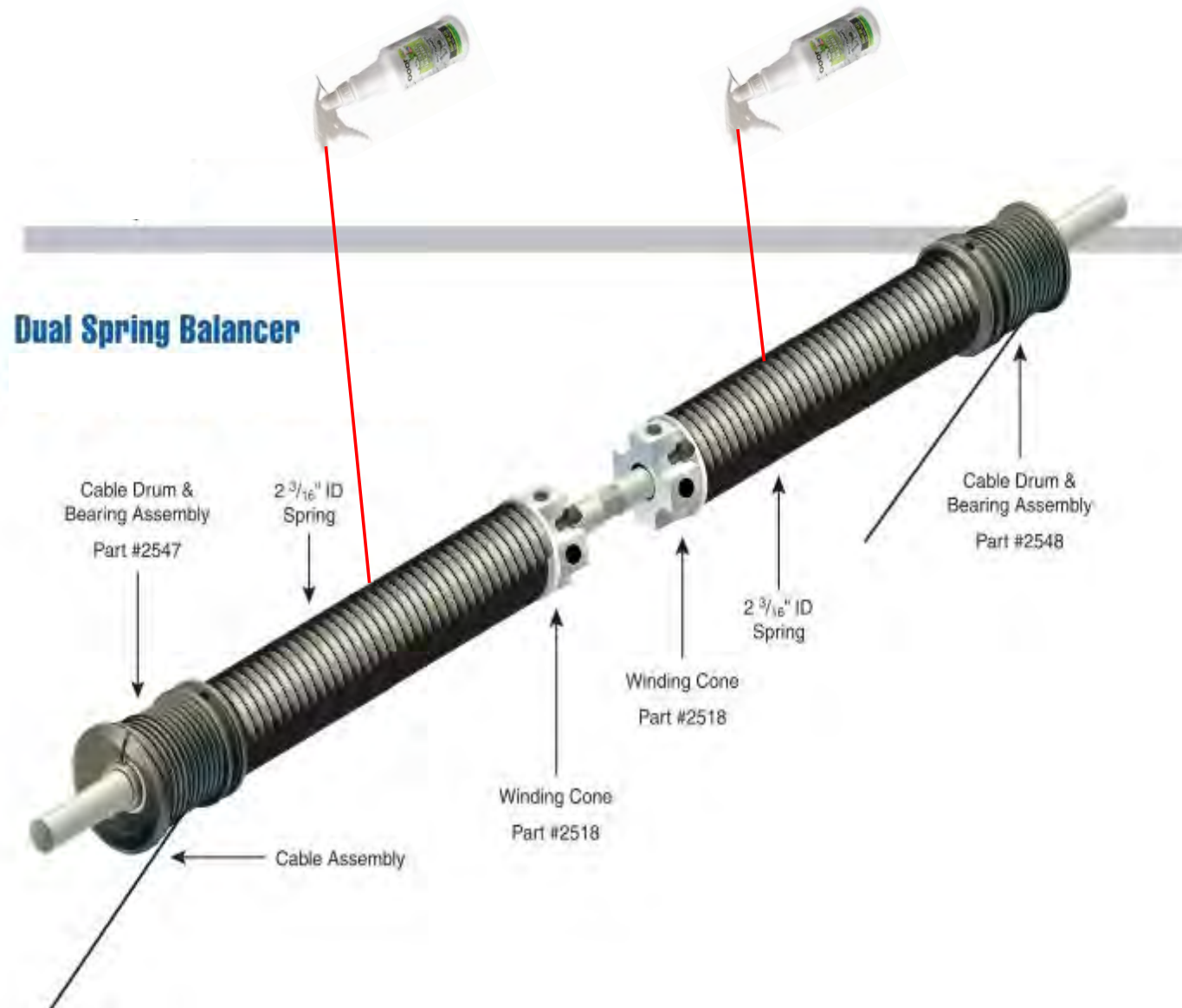

1. Check to see if the door lock operates easily and latches tight, compressing the bottom seal.
2. Check to see if the door operates freely (up and down) with side play between the tracks and door approximately 1/4" to 3/8".
3. Check for loose fasteners or other components.
4. Are the spacer washers installed at the 1st Intermediate hinge and the last intermediate hinge on both sides? (**4 required per roller on side doors & 6 required per roller on rear door** by door design, to keep the door from contacting the track). (See Figure 1).
5. Are the side seals installed in a manner that the seal uniformly contacts the door but doesn't bind or impede the door operation?
6. Inspect Roll-up Door Side Seals for wear/damage and replace if needed.
7. Does the top seal contact the header at the ends well as the middle while keeping the top panel in a vertical position? (See Figure 2).
8. Inspect Roll-up Door Top Seals for wear/damage and replace if needed.
9. Inspect Roll-up Door Pull Strap for fraying or wear damage and replace if needed. (See Figure 3).
10. On Roll-up Doors with 2-point latch system, Inspect Door Latch Cables for fraying or wear damage and replace if needed.

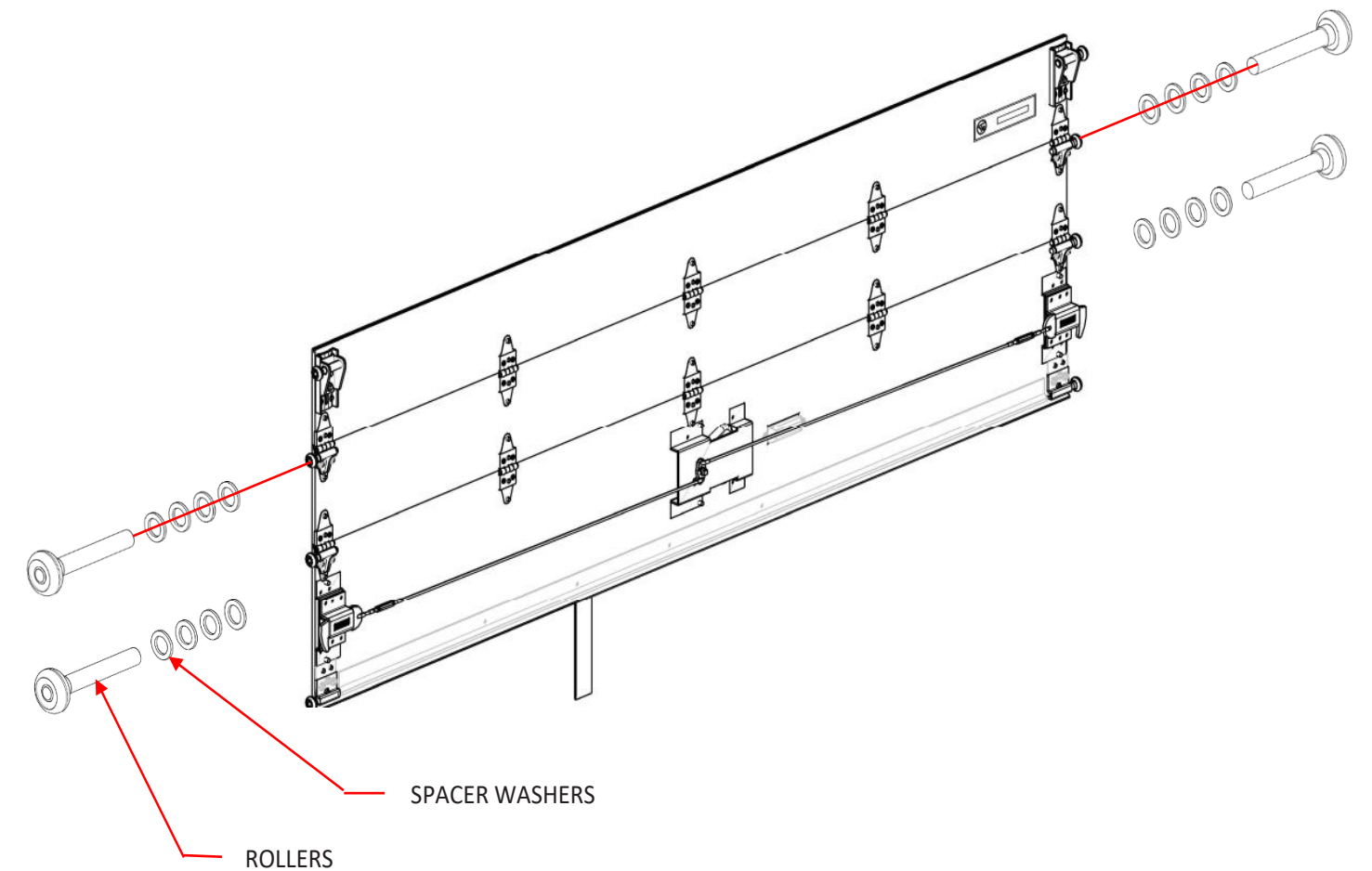

FIGURE 1

NOTICE

Loosen the two 5/16" nuts on both top fixture assemblies, adjust the top fixture slides until the top door panel is in the same plane as the rest of the door panels and retighten 5/16" nuts.

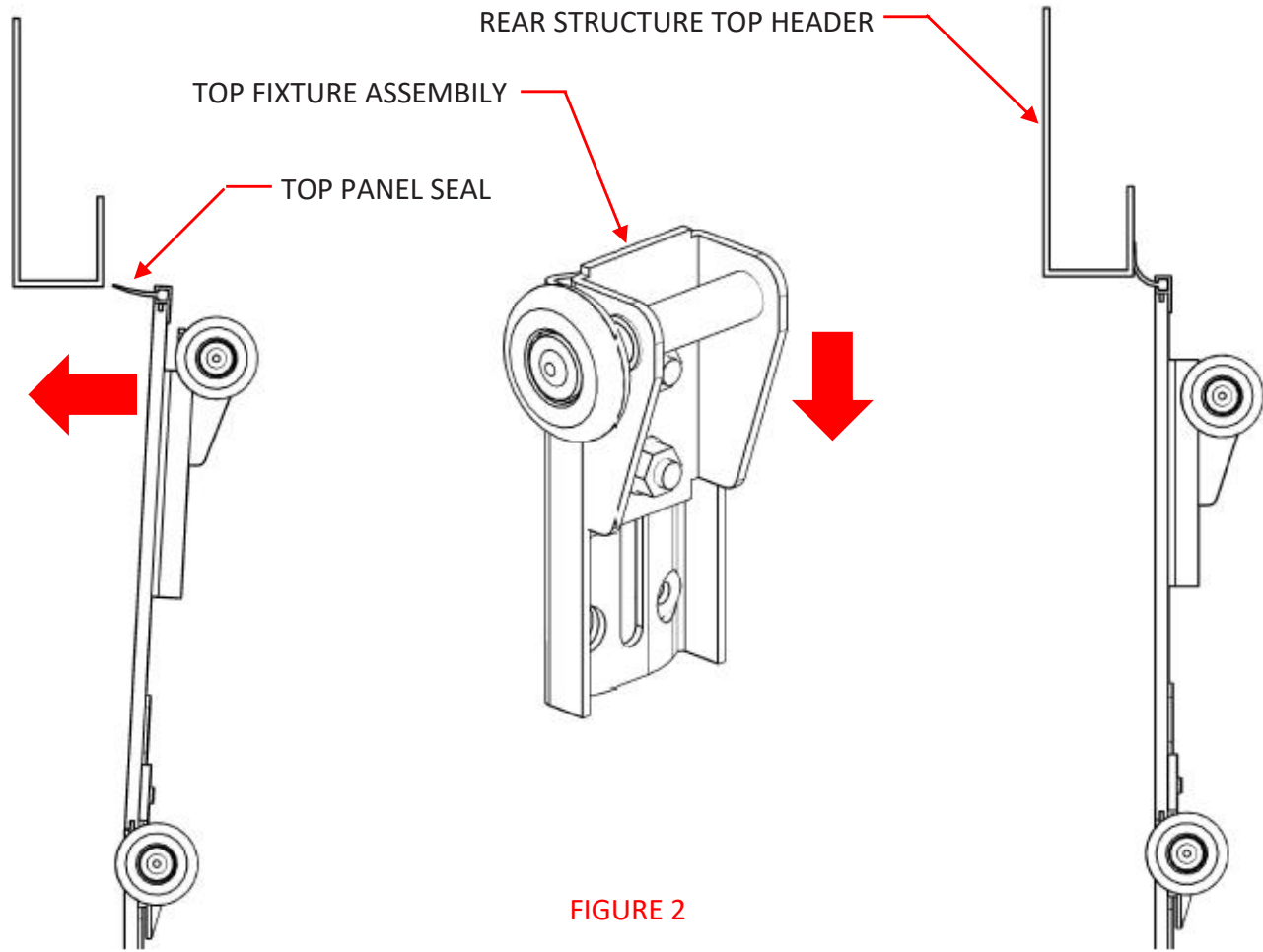

FIGURE 2

VIEW OF INCORRECT
TOP PANEL SEAL
CONTACT TO HEADER

VIEW OF CORRECT
TOP PANEL SEAL
CONTACT TO HEADER

PULL STRAP

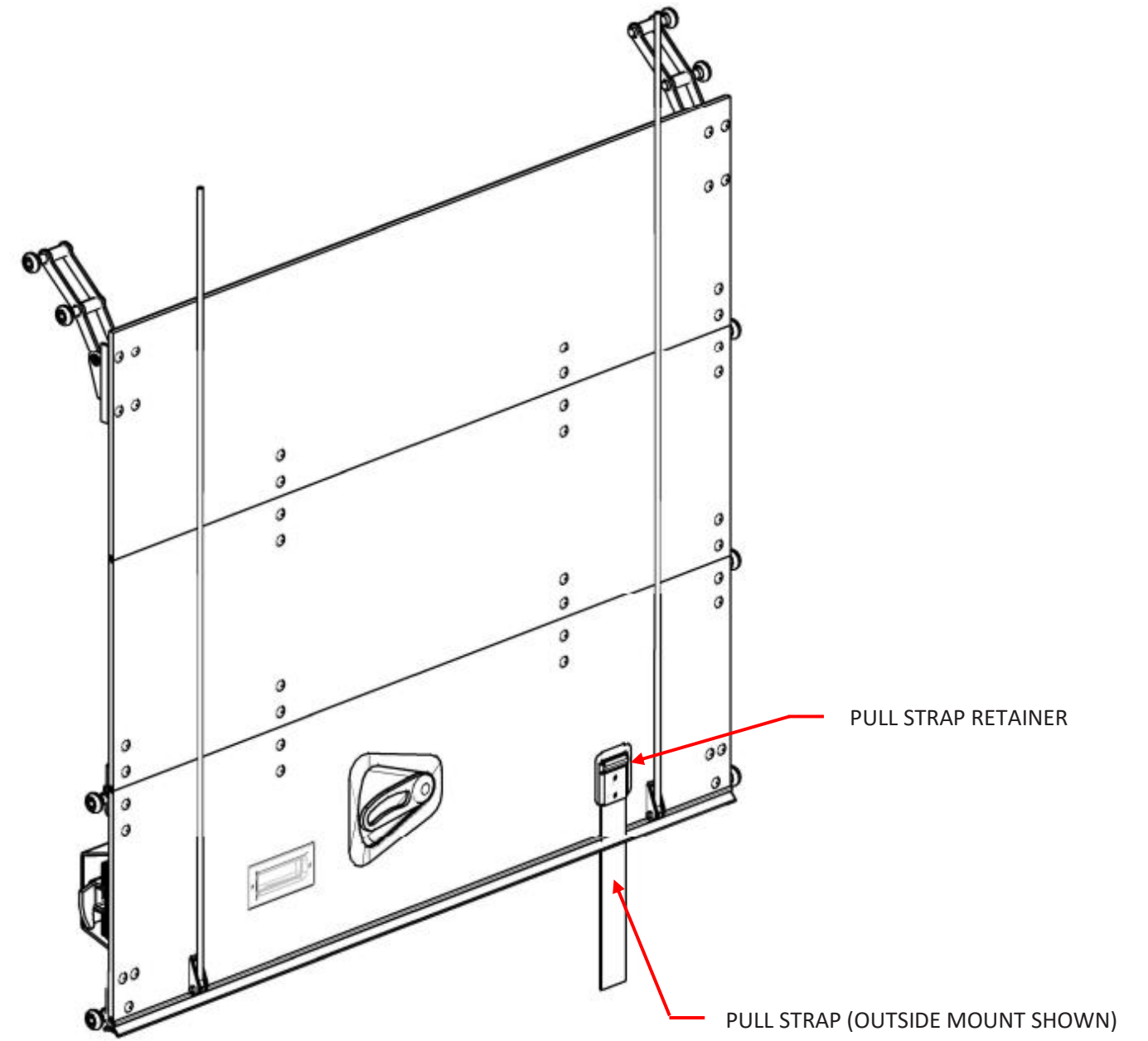

FIGURE 3

CAUTION

Failure to replace worn or frayed door pull strap may result in injury.

NOTICE

SPRING BALANCER – PLEASE INSPECT THE FOLLOWING:

Note: All spring systems are designed to assist in the operation of opening and closing the door. The door should never free fall or fly open buy itself. All spring systems are designed for both cables to have uniform pull, so the door doesn't pull to one side or the other.

1. Does the door "balance" (neither rise nor fall) without assistance?
2. Are the cables (door in open position) nearly vertical from the cable anchor bracket to the cable drum? The cables should NOT skip grooves or travel over another cable on the drum.
3. Inspect Roll-up Door Cables for fraying or wear damage and replace if needed. (See Figure 4).
4. Inspect Cotter Pins and Cable Anchor Bracket Pins for wear damage and replace if needed. (See Figure 4).

SINGLE SPRING – PLEASE INSPECT THE FOLLWING:

1. Are the cable drums tight against the counterbalance shaft bearings, the set screws properly tightened, and both cables are tight and have equal tension? (See Figure 5).

DUAL SPRING – PLEASE INSPECT THE FOLLWING:

1. Are both springs wound to the same number of turns?

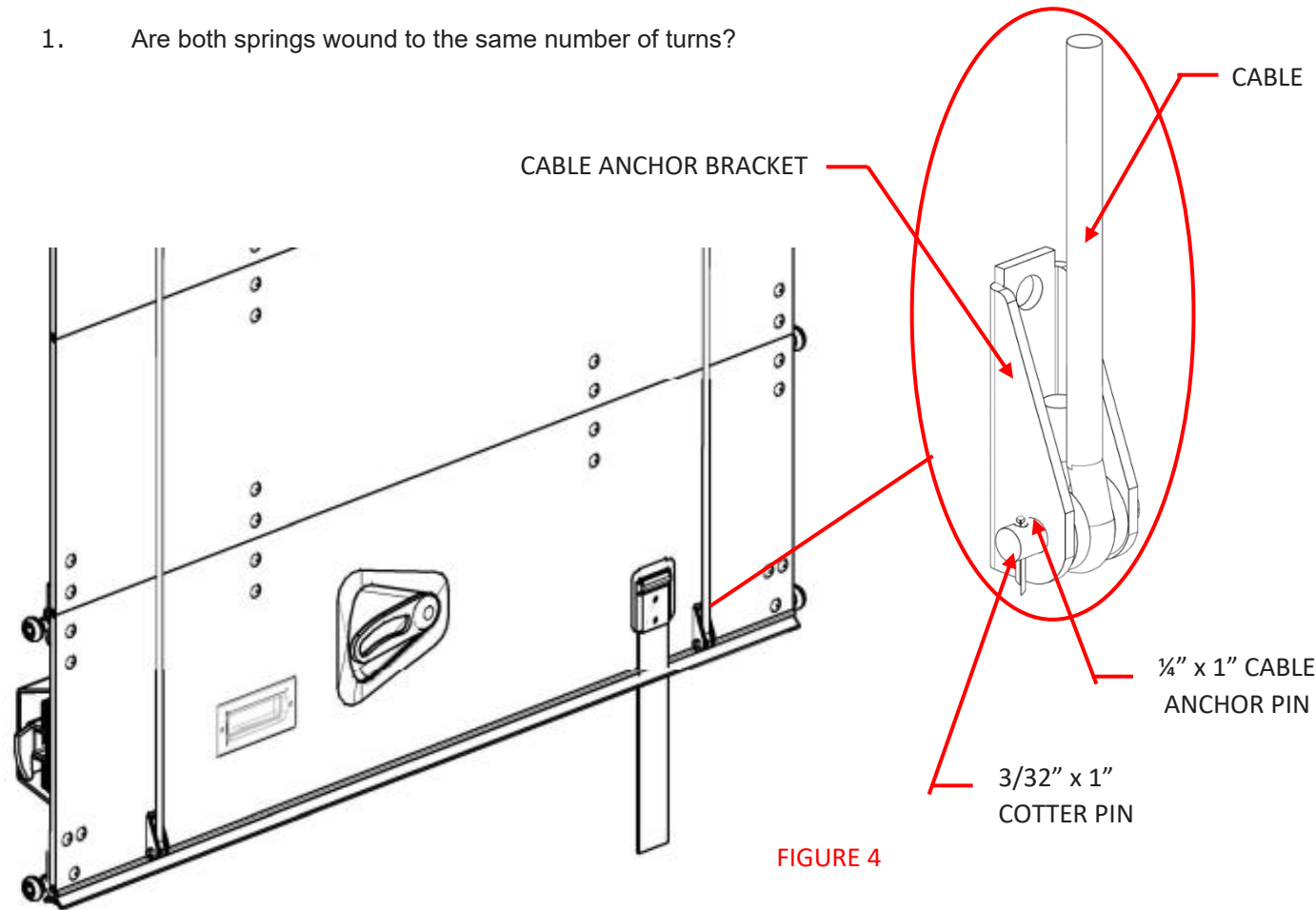

FIGURE 4

NOTICE

Cable drums need to be tight against counterbalance shaft bearing assemblies on both sides.

FOR REAR DOOR ONLY

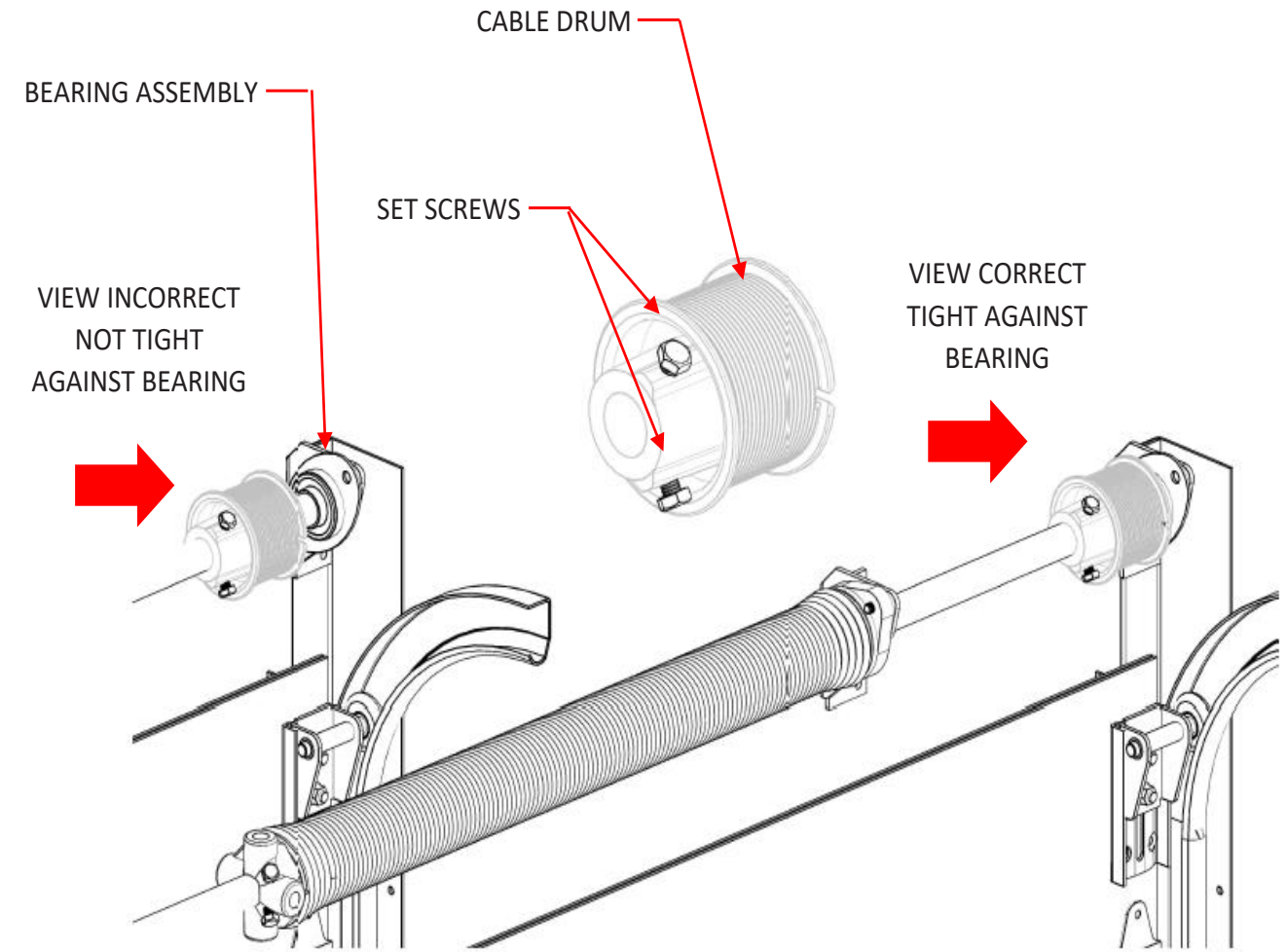

FIGURE 5

LOCATIONS OF TRANSGLOBAL'S SERIAL NUMBER PLATES

NOTICE

Transglobal location inside mount / top panel.

When ordering parts for roll-up door, specify the serial number of the door.

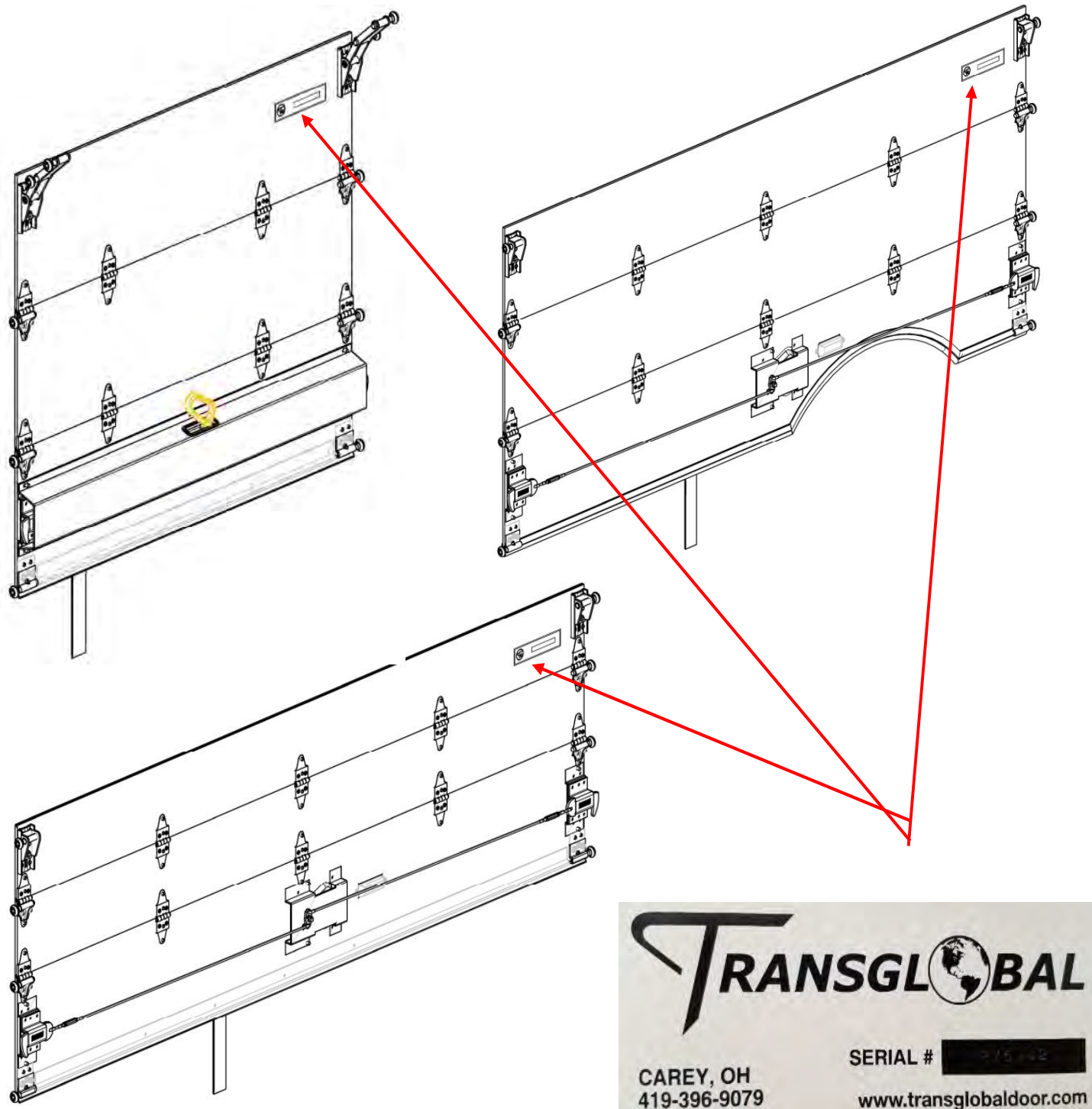

PAGE #	PART #	DESCRIPTION	QTY	UNIT
60	88117510	HARNESS JUMPER REAR 3WAY LOOSE CONECTIONS	1	EA
61-64	219082200	HARNESS CHASSIS RHD	1	EA
66-67	219084200	HARNESS INSTRUMENT PANEL RHD F150	1	EA
68-72	219084201	HARNESS CAB RHD F150	1	EA
73	219084203	HARNESS DOOR CAB RHD F150	2	EA
74	219084204	HARNESS DOOR CNCT JPR RHD F150	2	EA
75	219084207	HARNESS INSTRUMENT PANEL CENTER F150	1	EA
76-81	219085201	HARNESS HOOD RHD F150	1	EA
82-84	219086200	HARNESS REAR LIGHTING RHD F150	1	EA
85	219088200	HARNESS JUMPER RCM	1	EA
86-87	219093200	HARNESS ROOF CARGO RHD F150	1	EA
88	219093201	HARNESS ROOF CAB RHD F150	1	EA
89	49013476	CABLE CAMERA TO MONITOR 12'	1	EA
89	49013477	CABLE CAMERA TO MONITOR 22'	1	EA
90	49013959	HARNESS SPEAKER WIRING	1	EA
91	229079200	HARNESS RADIO POWER JUMPER WIRE	1	EA
92	229088200	HARNESS PARK SWITCH	1	EA

Section 13-2 Wiring Harness Diagrams

DRAWING NO.	REV	SHT
88117510		1 OF 1
REV.	DESCRIPTION	BY
	RELEASE FOR PRODUCTION	

NOTE: CAVITY DESIGNATIONS FOR MORGAN INSTALL PURPOSES ONLY

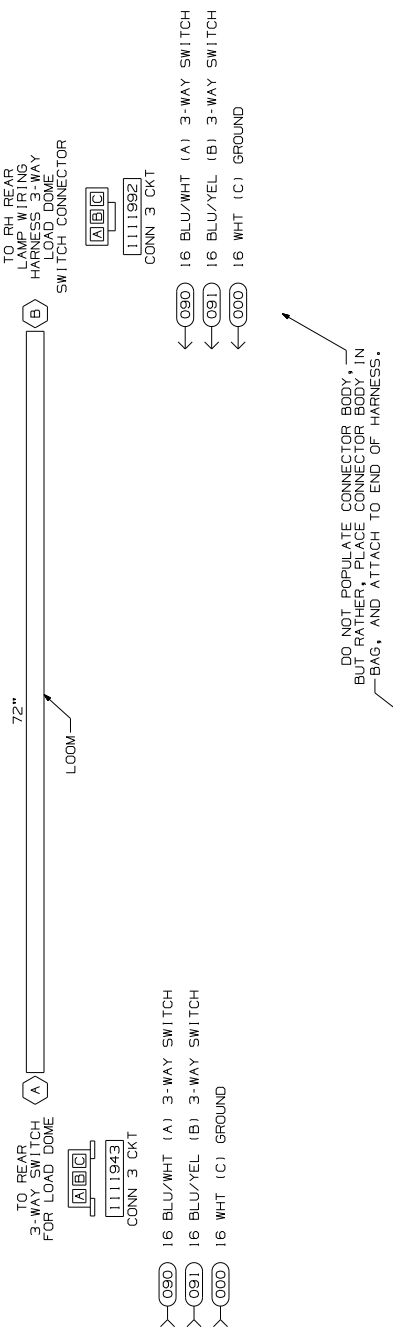

DO NOT POPULATE CONNECTOR BODY, BUT RATHER, PLACE CONNECTOR BODY IN BAG, AND ATTACH TO END OF HARNESS.

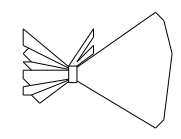

NOTES:

1. GXL WIRE.
2. SPLIT POLY LOOM UNLESS OTHERWISE NOTED.
3. HARNESS TO HAVE A LABEL SHOWING MORGAN OLSON PART NUMBER, REVISION DATE OF MANUFACTURE.
4. TAPE [1111098]: 6" AT BREAKOUTS AND 2" AT LOOM ENDS.
5. SPLICES TO BE AUTOMATED WITH SOLDER, AND ADHESIVE LINED HEAT SHRINK TUBING.
6. CONNECTORS SHOWN FROM WIRE ENTRY SIDE, UNLESS OTHERWISE NOTED.
7. HARNESS TO BE TESTED FOR CONTENT, OPENS, SHORTS, AND CONTINUITY.
8. VENDOR MAY REPLACE PIGTAILS WITH WIRING TO APPROVED MOLDINGS OR CONNECTIONS. PIGTAILS SHOWN IN TERMINAL VIEW.
9. THIS IS A PURCHASED HARNESS. NO BILL OF MATERIAL EXISTS.

PROPRIETARY
This drawing and the information and data contained herein are the property of Morgan Olson and may not be copied, reproduced, or transmitted in any form or by any means, electronic or mechanical, including photocopying, recording, or by any information storage and retrieval system, without the prior written consent of Morgan Olson.



GENERAL STANDARDS UNLESS OTHERWISE NOTED:
1. ALL DIMENSIONS IN INCHES UNLESS OTHERWISE NOTED.
2. DIMENSIONS IN PARENTHESIS ARE MFG TOLERANCES.
3. DIMENSIONS IN SQUARE PARENTHESIS ARE MFG TOLERANCES.
4. DIMENSIONS IN BRACKETED PARENTHESIS ARE MFG TOLERANCES.
5. DIMENSIONS IN DASHED PARENTHESIS ARE MFG TOLERANCES.
6. DIMENSIONS IN DOTTED PARENTHESIS ARE MFG TOLERANCES.
7. DIMENSIONS IN SOLID PARENTHESIS ARE MFG TOLERANCES.
8. DIMENSIONS IN SOLID PARENTHESIS ARE MFG TOLERANCES.
9. DIMENSIONS IN SOLID PARENTHESIS ARE MFG TOLERANCES.
10. DIMENSIONS IN SOLID PARENTHESIS ARE MFG TOLERANCES.

HARNESS AND LOOM TOLERANCES
UP TO 60" = -0/+2"
60" TO 100" = -0/+4"
100" TO 200" = -0/+5"
200" TO 400" = -0/+6"
400" TO 600" = -0/+7"
OVER 600" = -0/+9"
60 TO 600" = -0/+2"

LENGTHS APPLY FROM BREAKOUT TO BREAKOUT, OR BREAKOUT TO WIRE ENTRY POINT OF CONNECTOR, OR END OF COVER, FOR OR END OF COVER.

FIRST USE: C1100619

Section 13-2 Wiring Harness Diagrams

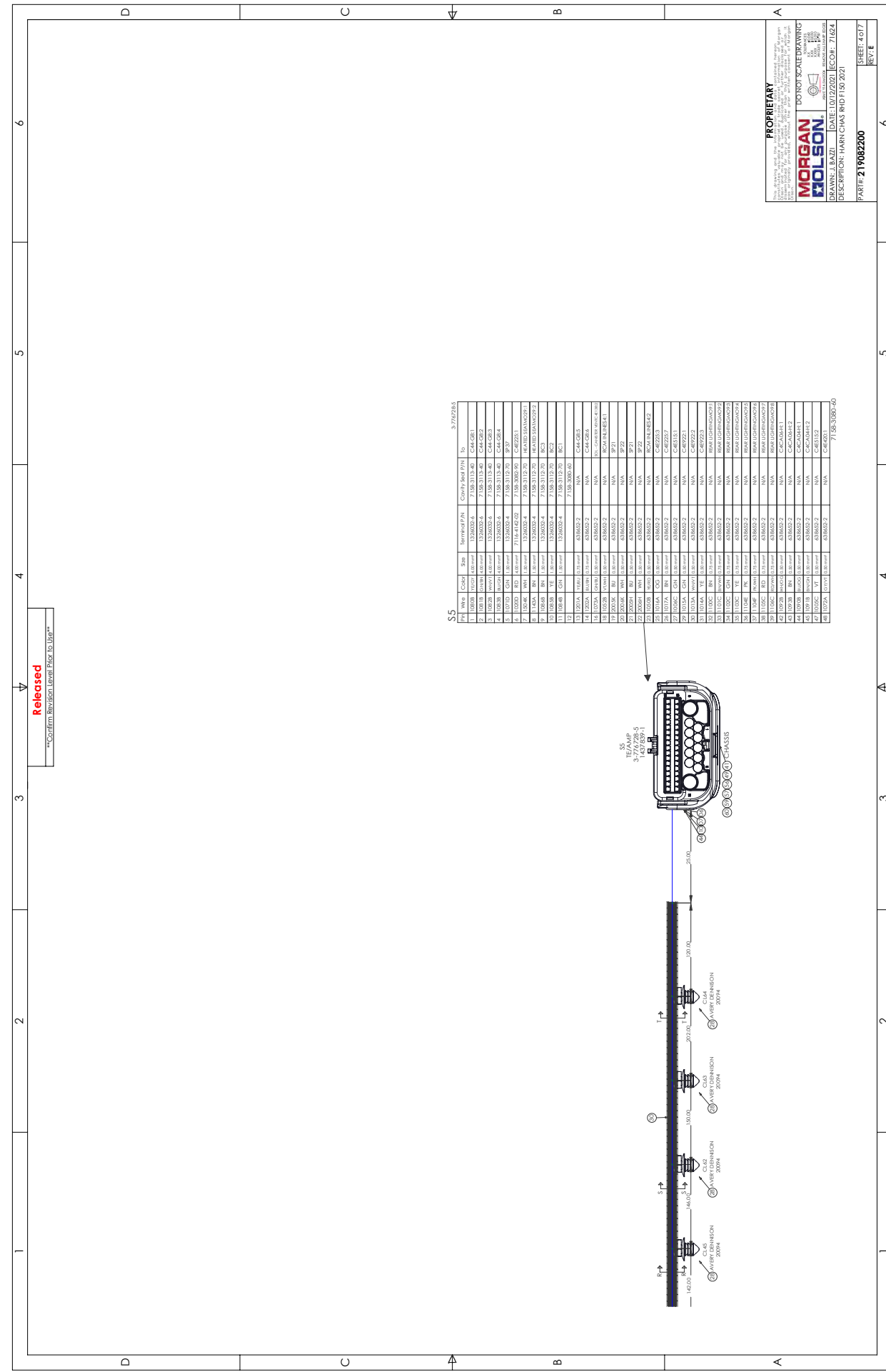

Released
Confirm Revision Level Prior To Use

Pin	Color	Wiring	Notes
1	BLU	132002.4	CA4-021
2	BLU	132002.4	CA4-021
3	BLU	132002.4	CA4-021
4	BLU	132002.4	CA4-021
5	BLU	132002.4	CA4-021
6	BLU	132002.4	CA4-021
7	BLU	132002.4	CA4-021
8	BLU	132002.4	CA4-021
9	BLU	132002.4	CA4-021
10	BLU	132002.4	CA4-021
11	BLU	132002.4	CA4-021
12	BLU	132002.4	CA4-021
13	BLU	132002.4	CA4-021
14	BLU	132002.4	CA4-021
15	BLU	132002.4	CA4-021
16	BLU	132002.4	CA4-021
17	BLU	132002.4	CA4-021
18	BLU	132002.4	CA4-021
19	BLU	132002.4	CA4-021
20	BLU	132002.4	CA4-021
21	BLU	132002.4	CA4-021
22	BLU	132002.4	CA4-021
23	BLU	132002.4	CA4-021
24	BLU	132002.4	CA4-021
25	BLU	132002.4	CA4-021
26	BLU	132002.4	CA4-021
27	BLU	132002.4	CA4-021
28	BLU	132002.4	CA4-021
29	BLU	132002.4	CA4-021
30	BLU	132002.4	CA4-021
31	BLU	132002.4	CA4-021
32	BLU	132002.4	CA4-021
33	BLU	132002.4	CA4-021
34	BLU	132002.4	CA4-021
35	BLU	132002.4	CA4-021
36	BLU	132002.4	CA4-021
37	BLU	132002.4	CA4-021
38	BLU	132002.4	CA4-021
39	BLU	132002.4	CA4-021
40	BLU	132002.4	CA4-021
41	BLU	132002.4	CA4-021
42	BLU	132002.4	CA4-021
43	BLU	132002.4	CA4-021
44	BLU	132002.4	CA4-021
45	BLU	132002.4	CA4-021
46	BLU	132002.4	CA4-021
47	BLU	132002.4	CA4-021
48	BLU	132002.4	CA4-021

Section 13-2 Wiring Harness Diagrams

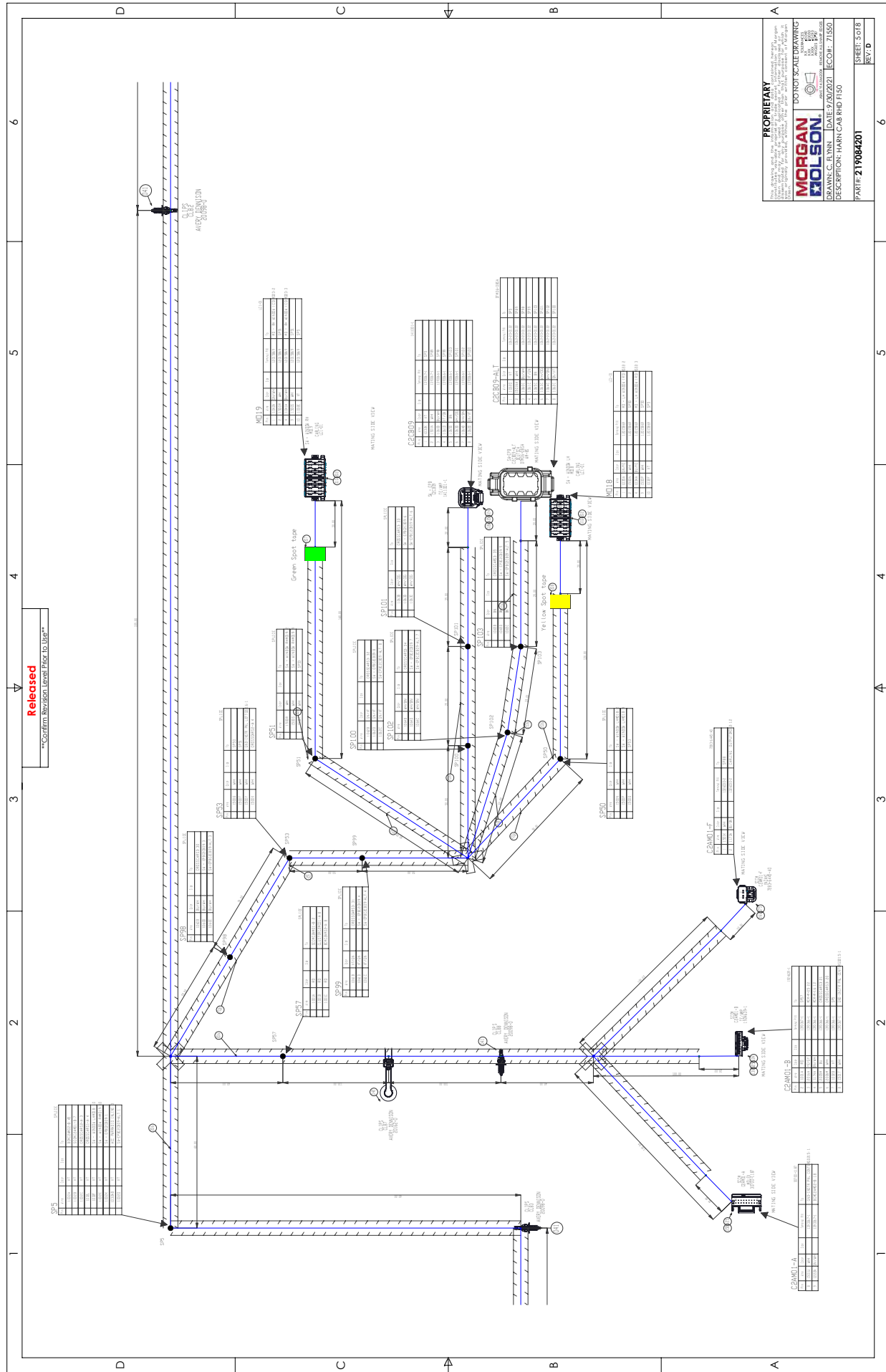

Section 13-2 Wiring Harness Diagrams

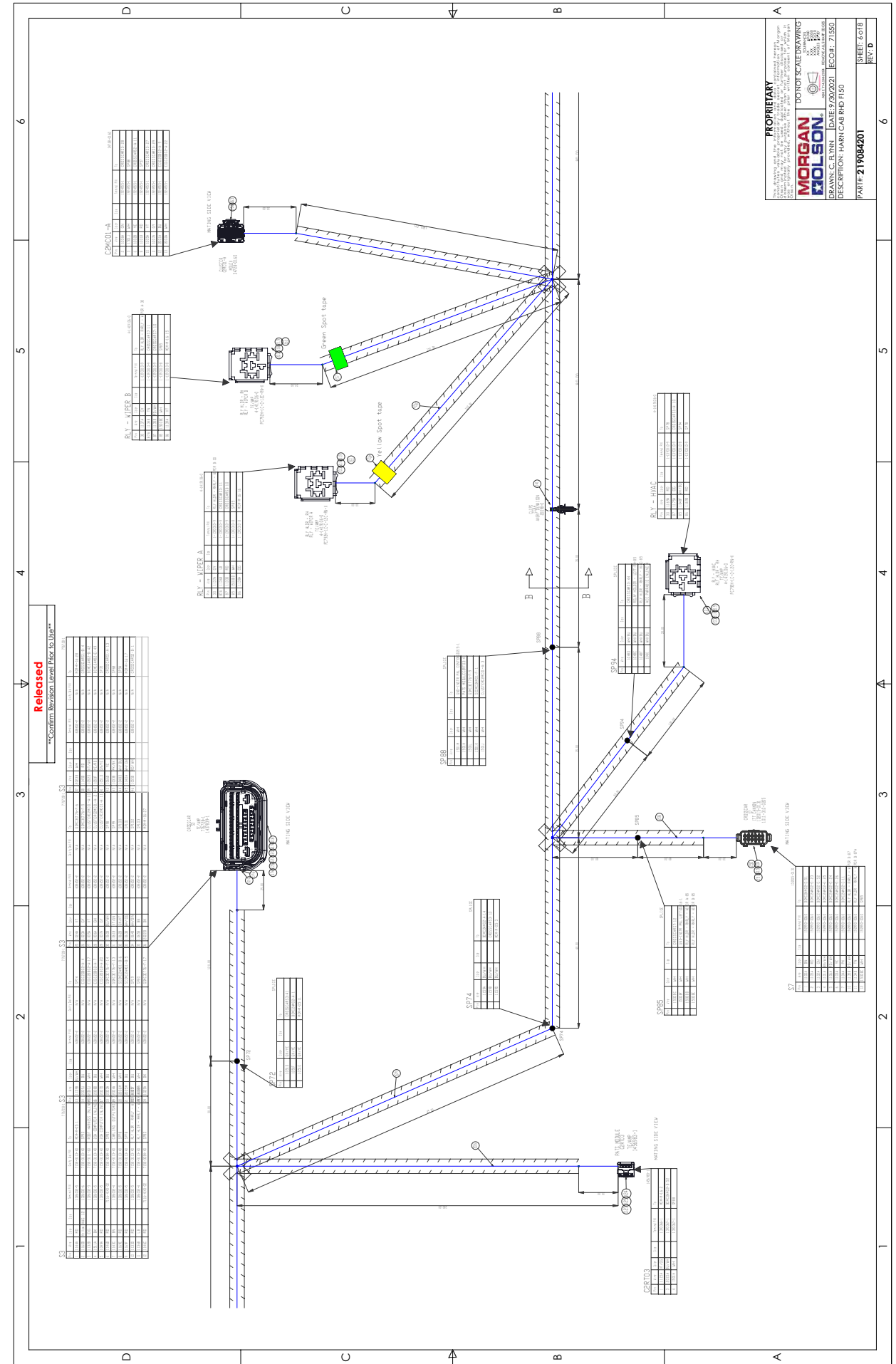

Section 13-2 Wiring Harness Diagrams

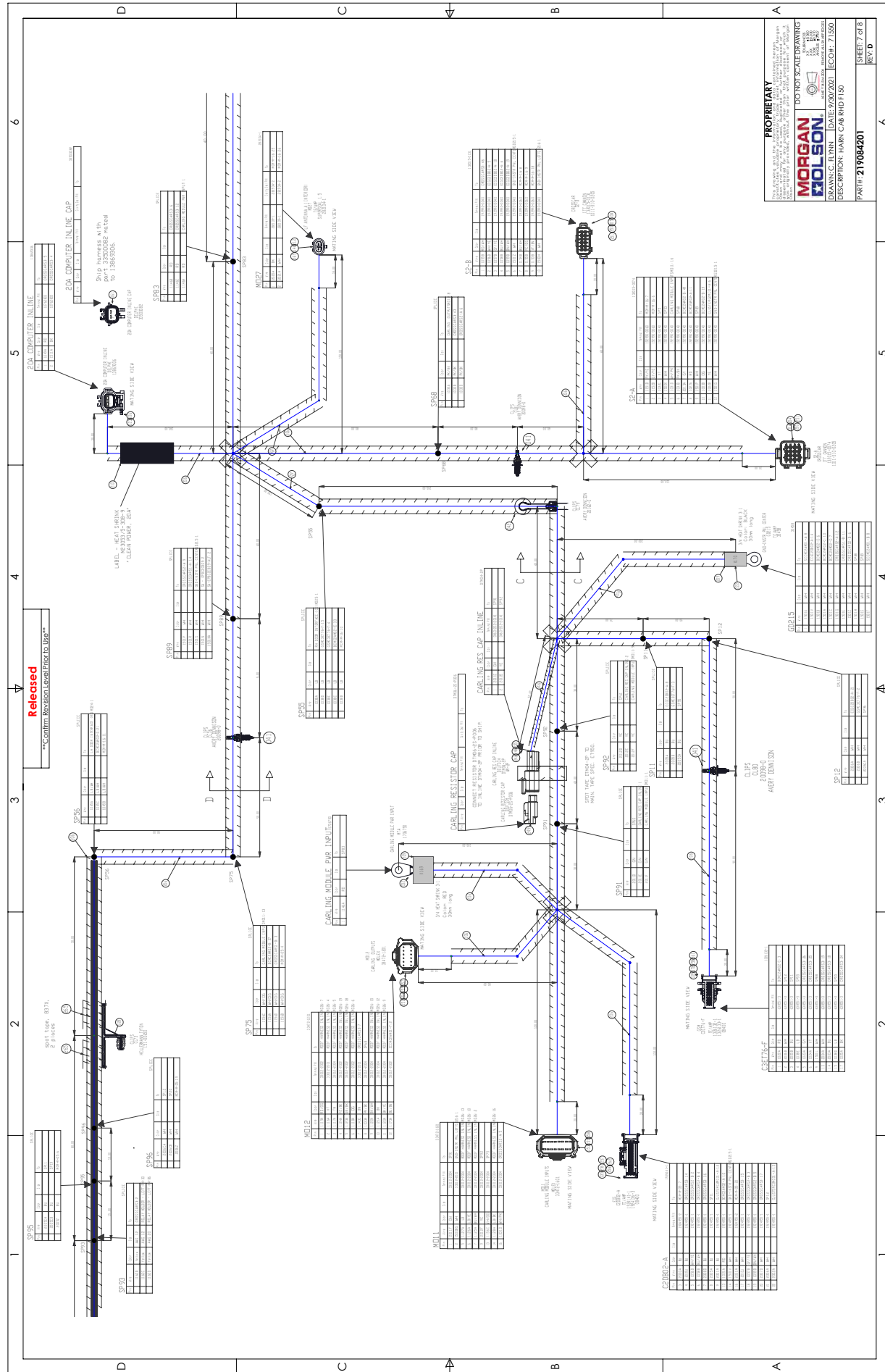

Section 13-2 Wiring Harness Diagrams

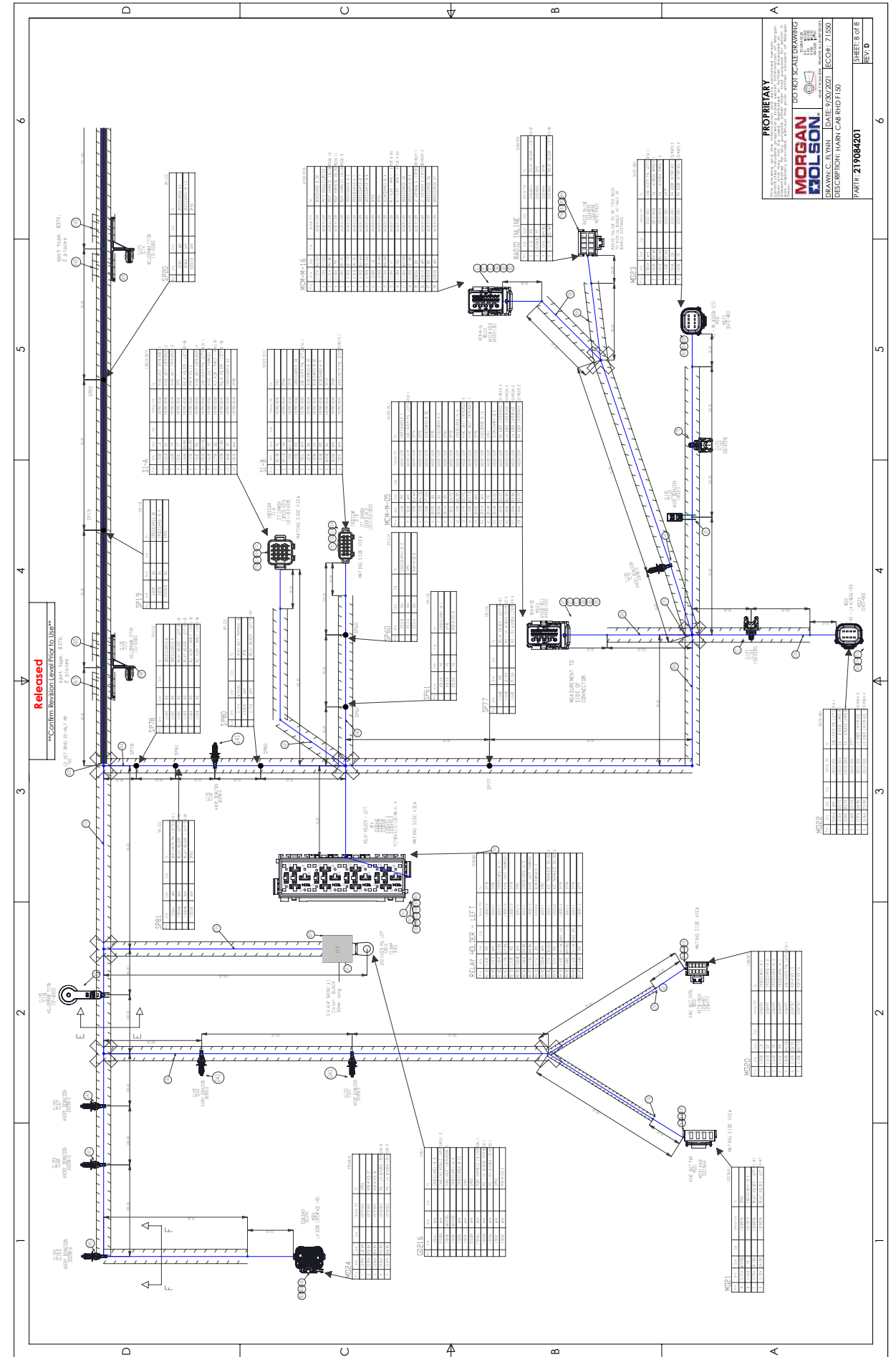

Section 13-2 Wiring Harness Diagrams

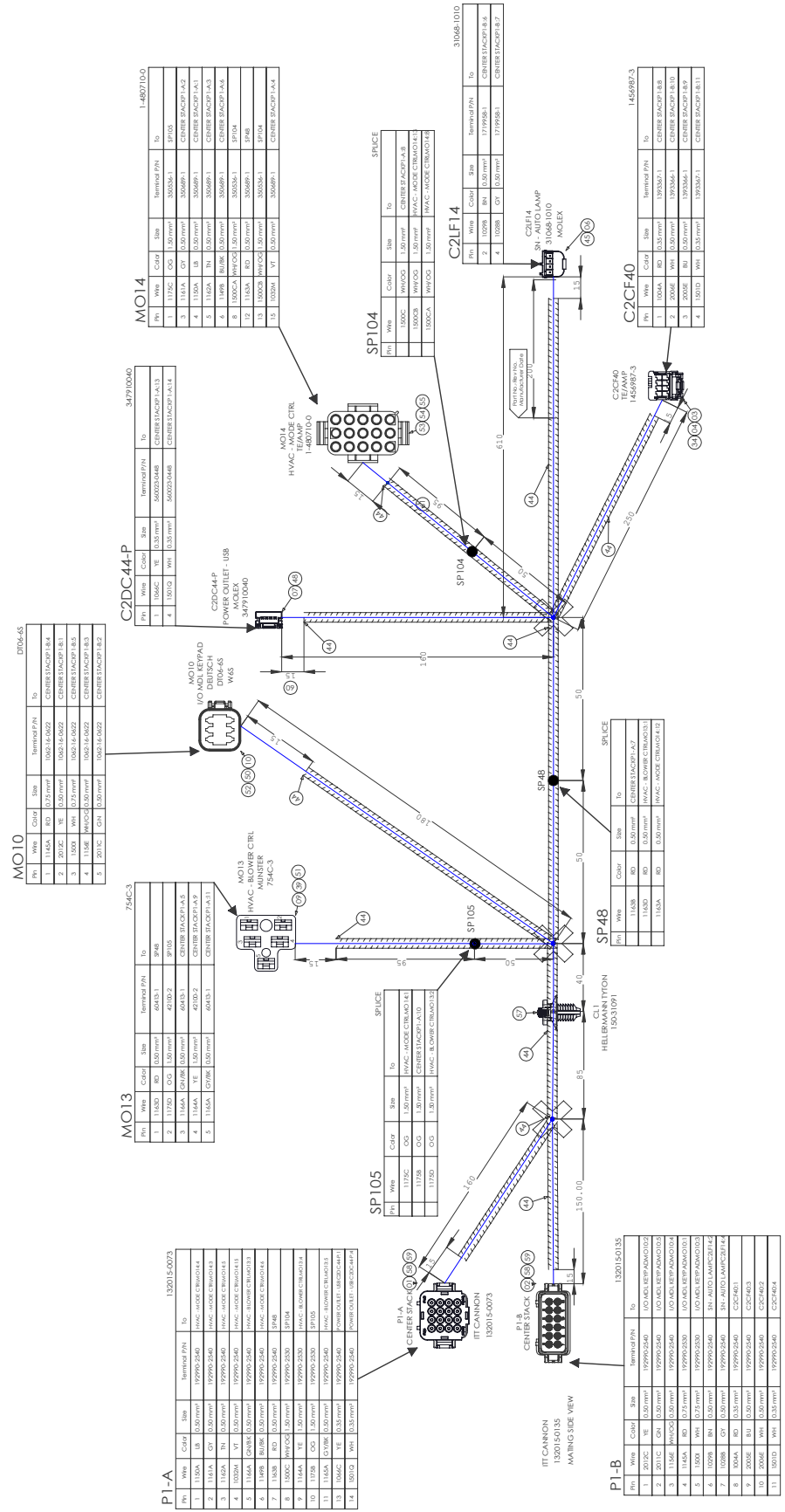

PROPRIETARY
 This drawing and the information it contains are the property of Morgan Polson. It is to be used only for the specific purpose for which it was prepared. It is not to be reproduced, stored in a retrieval system, or transmitted in any form or by any means, electronic, mechanical, photocopying, recording, or by any information storage and retrieval system, without the prior written permission of Morgan Polson.
MORGAN POLSON
 DO NOT SCALE DRAWING
 DRAWN: A. AHMED | DATE: 10/5/2021 | ECOH: 71349
 DESCRIPTION: HARN I/P CTR F150
 PART #: 219084207
 SHEET: 2 of 2
 REV: E

Section 13-2 Wiring Harness Diagrams

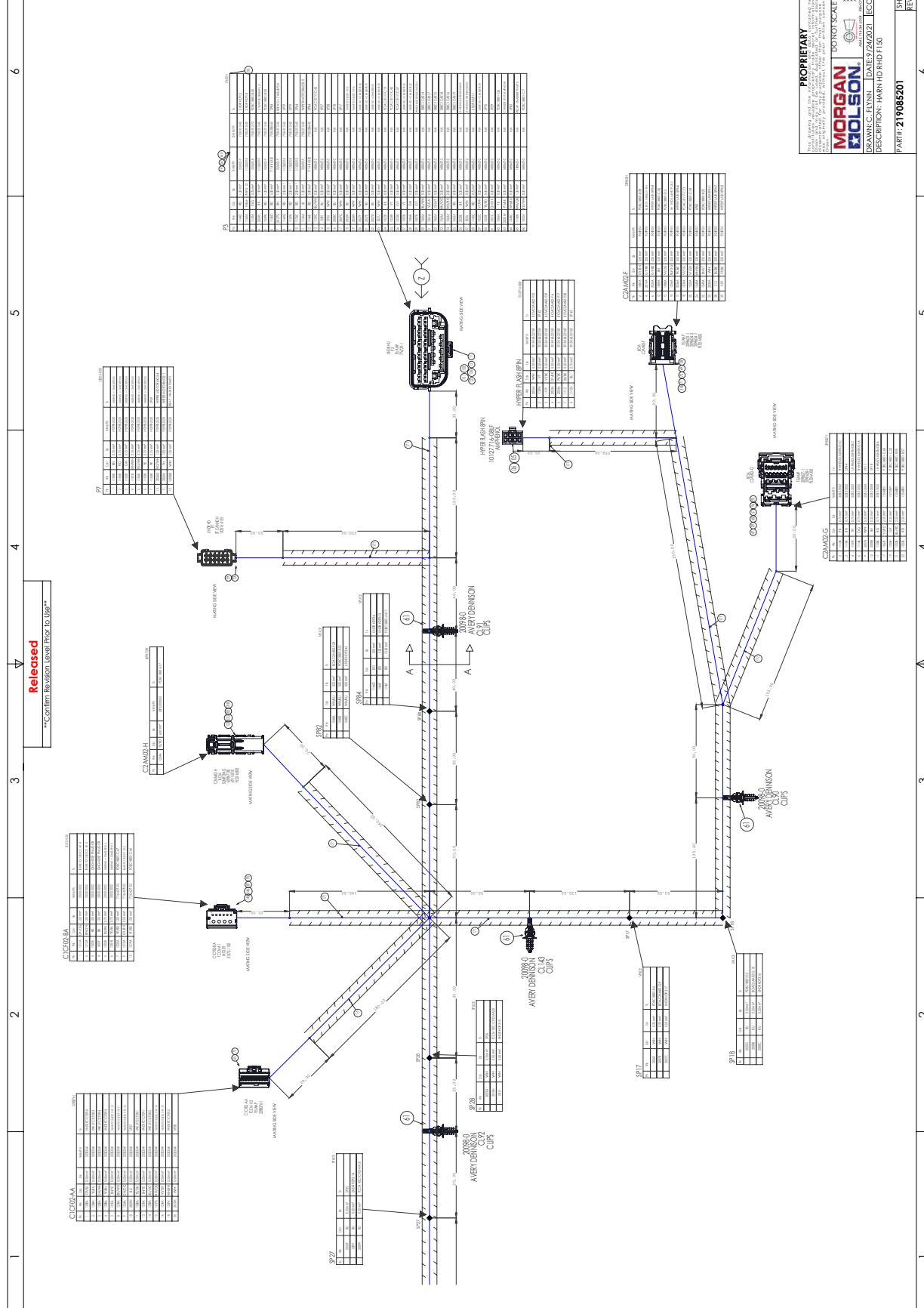

PROPRIETARY
 This drawing and the information it contains are the property of Morgan Polson. It is to be used only for the specific purpose for which it was prepared. It is not to be reproduced, stored in a retrieval system, or transmitted in any form or by any means, electronic, mechanical, photocopying, recording, or by any information storage and retrieval system, without the prior written permission of Morgan Polson.
MORGAN POLSON
 DO NOT SCALE DRAWING
 DRAWN: A. AHMED | DATE: 10/5/2021 | ECOH: 71349
 DESCRIPTION: HARN I/P CTR F150
 PART #: 219084207
 SHEET: 3 of 3
 REV: D

Released
 Confirm Revision Level Prior to Use

Released
 Confirm Revision Level Prior to Use

Section 13-2 Wiring Harness Diagrams

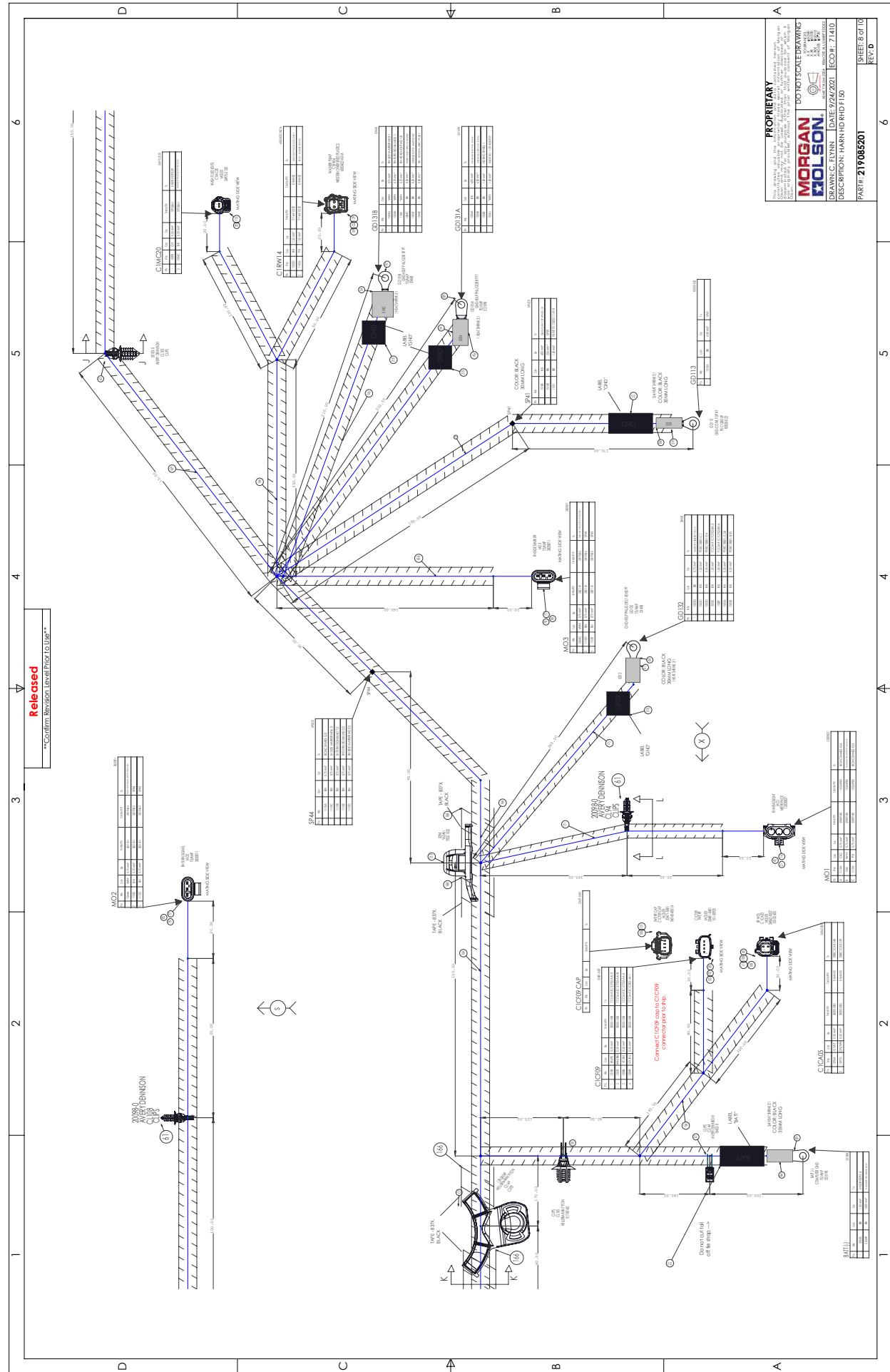

Section 13-2 Wiring Harness Diagrams

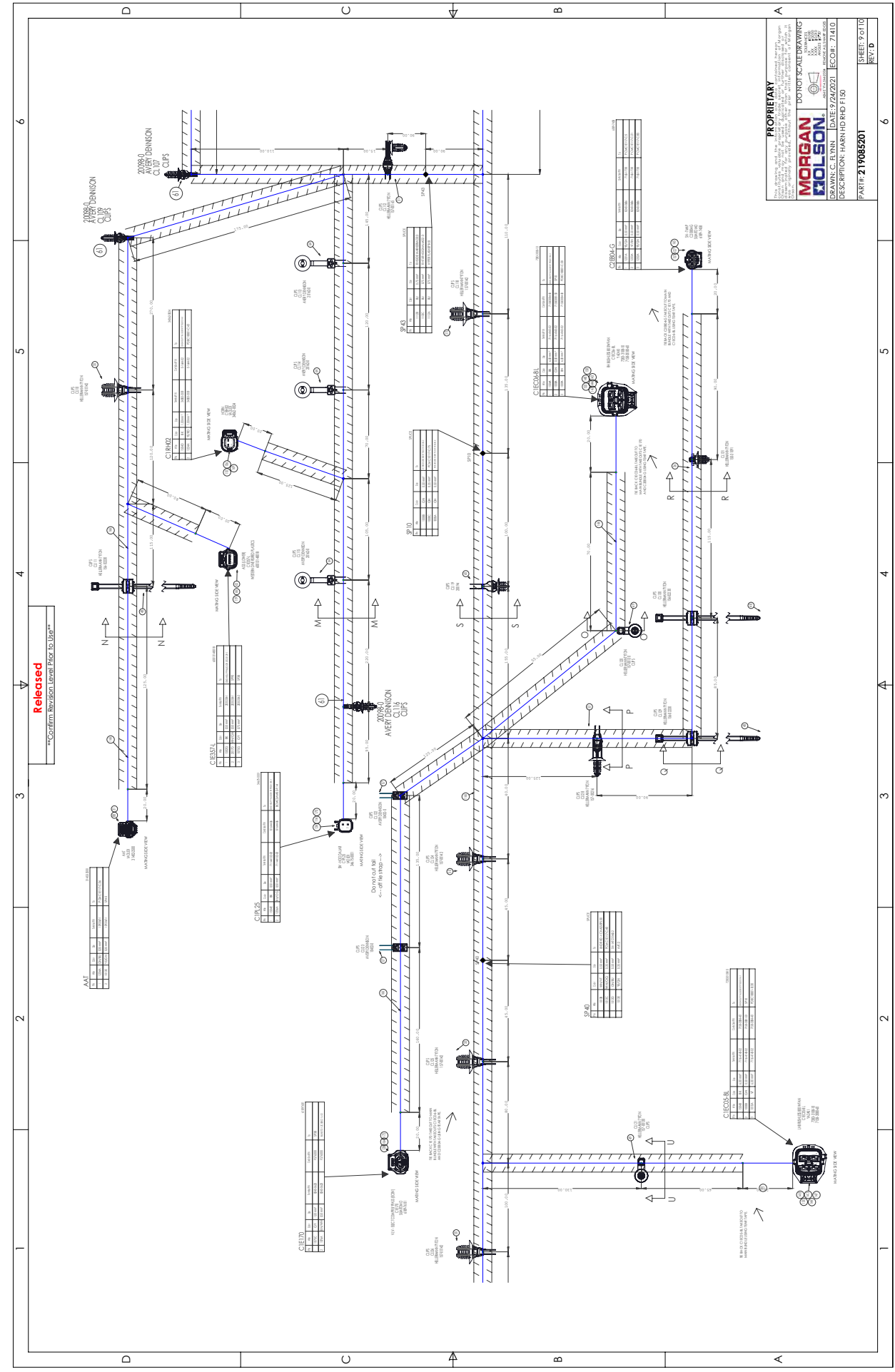

Section 13-2 Wiring Harness Diagrams

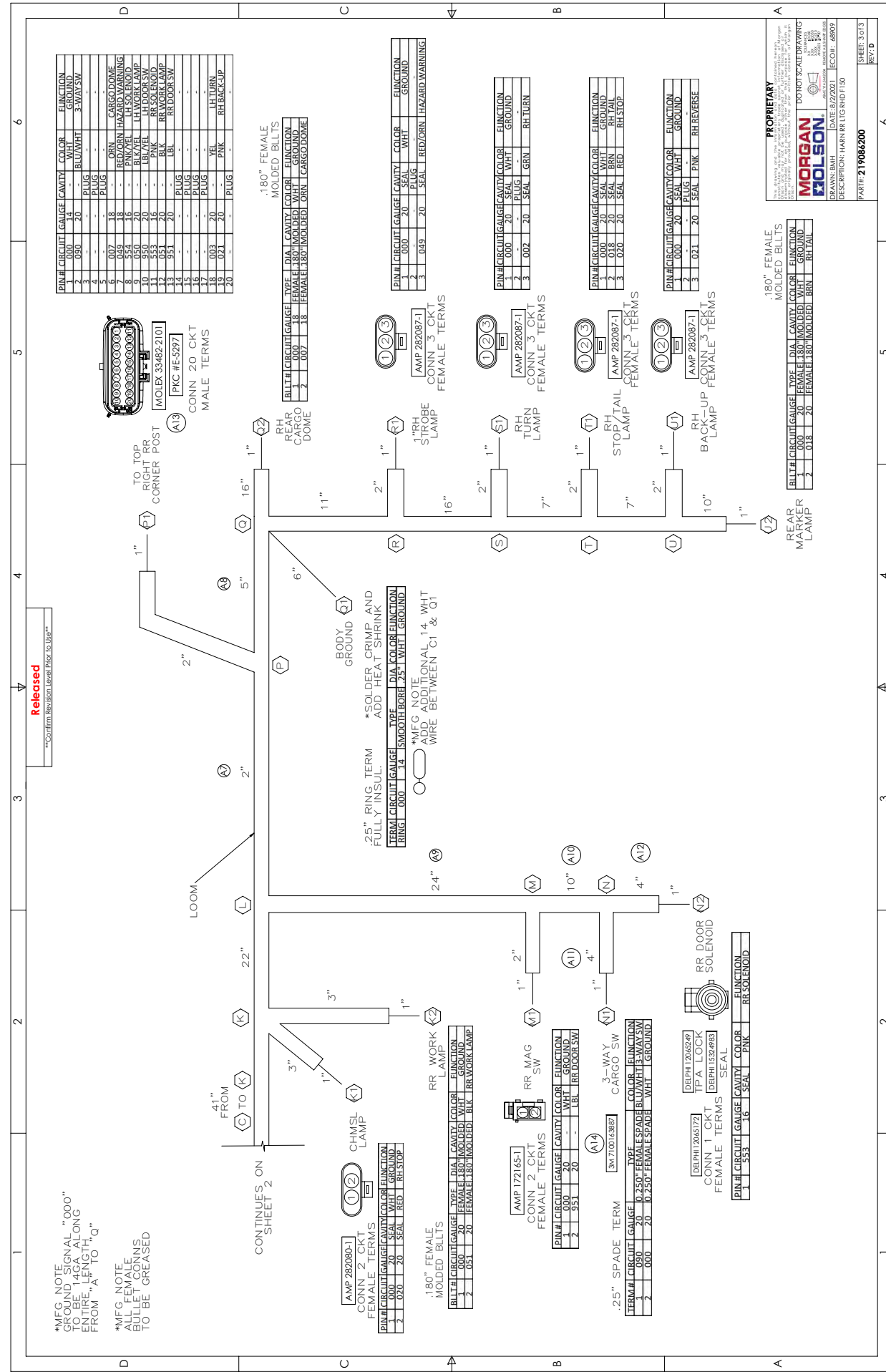

Section 13-2 Wiring Harness Diagrams

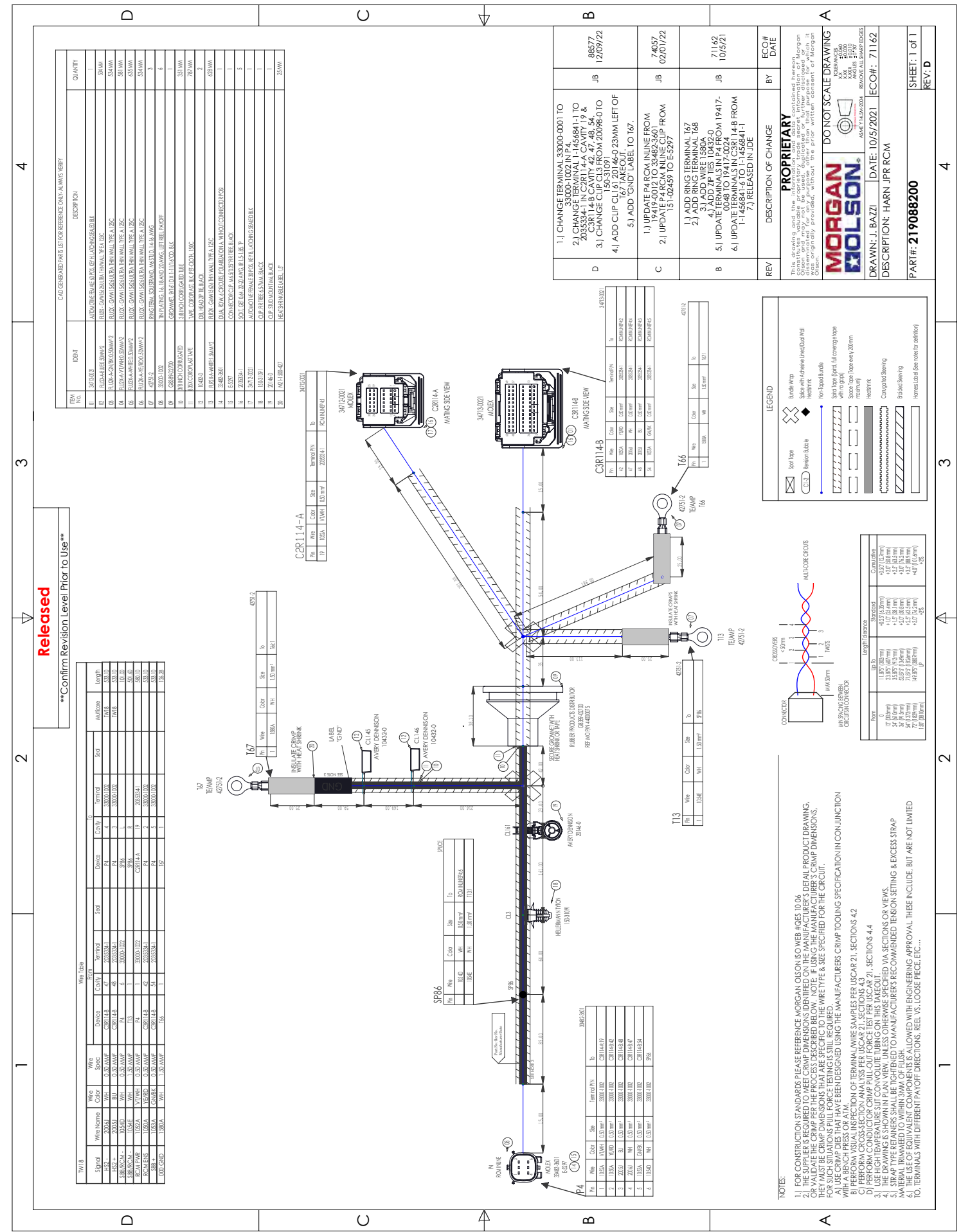

Section 13-2 Wiring Harness Diagrams

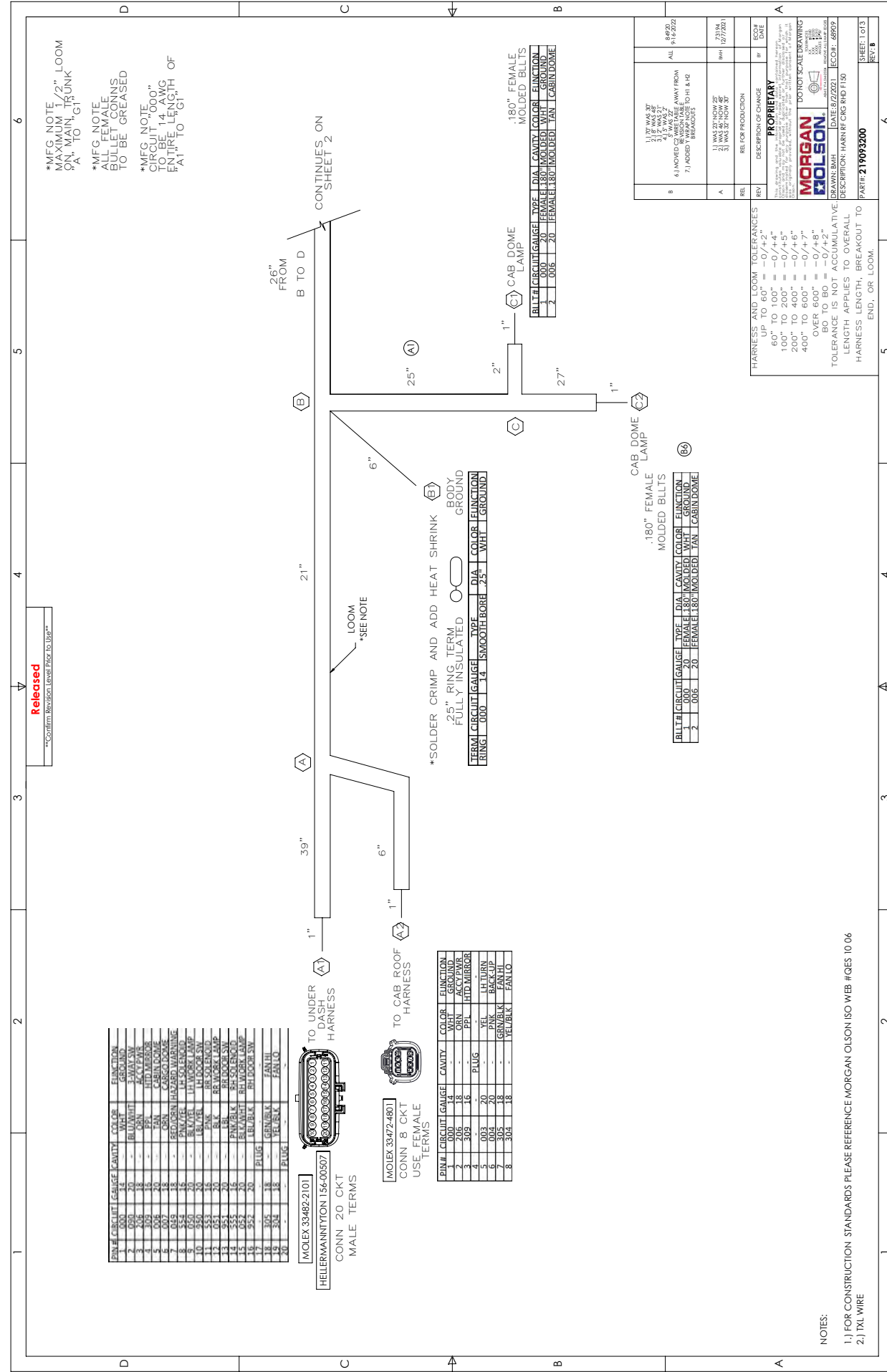

Section 13-2 Wiring Harness Diagrams

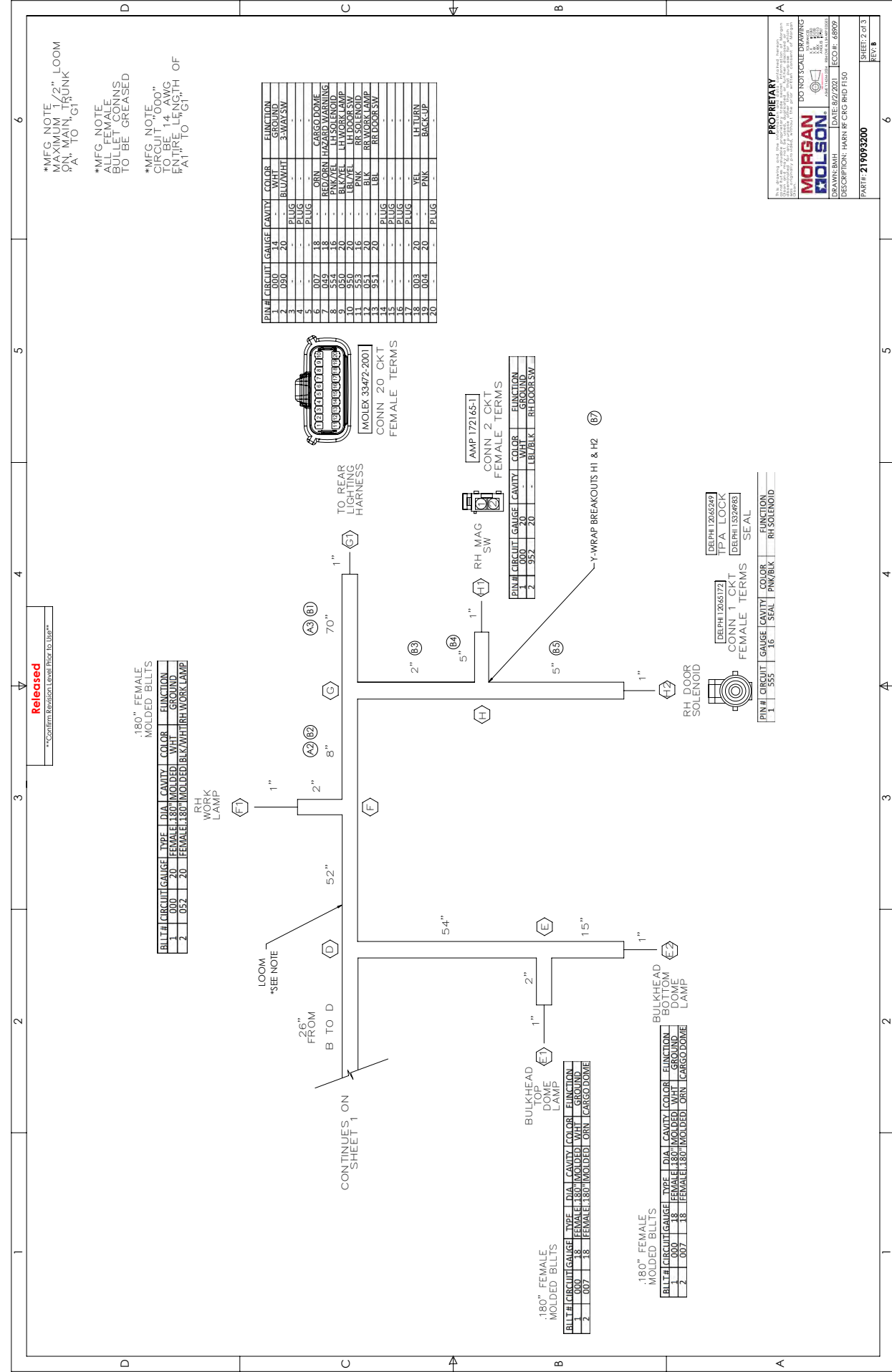

Section 13-2 Wiring Harness Diagrams

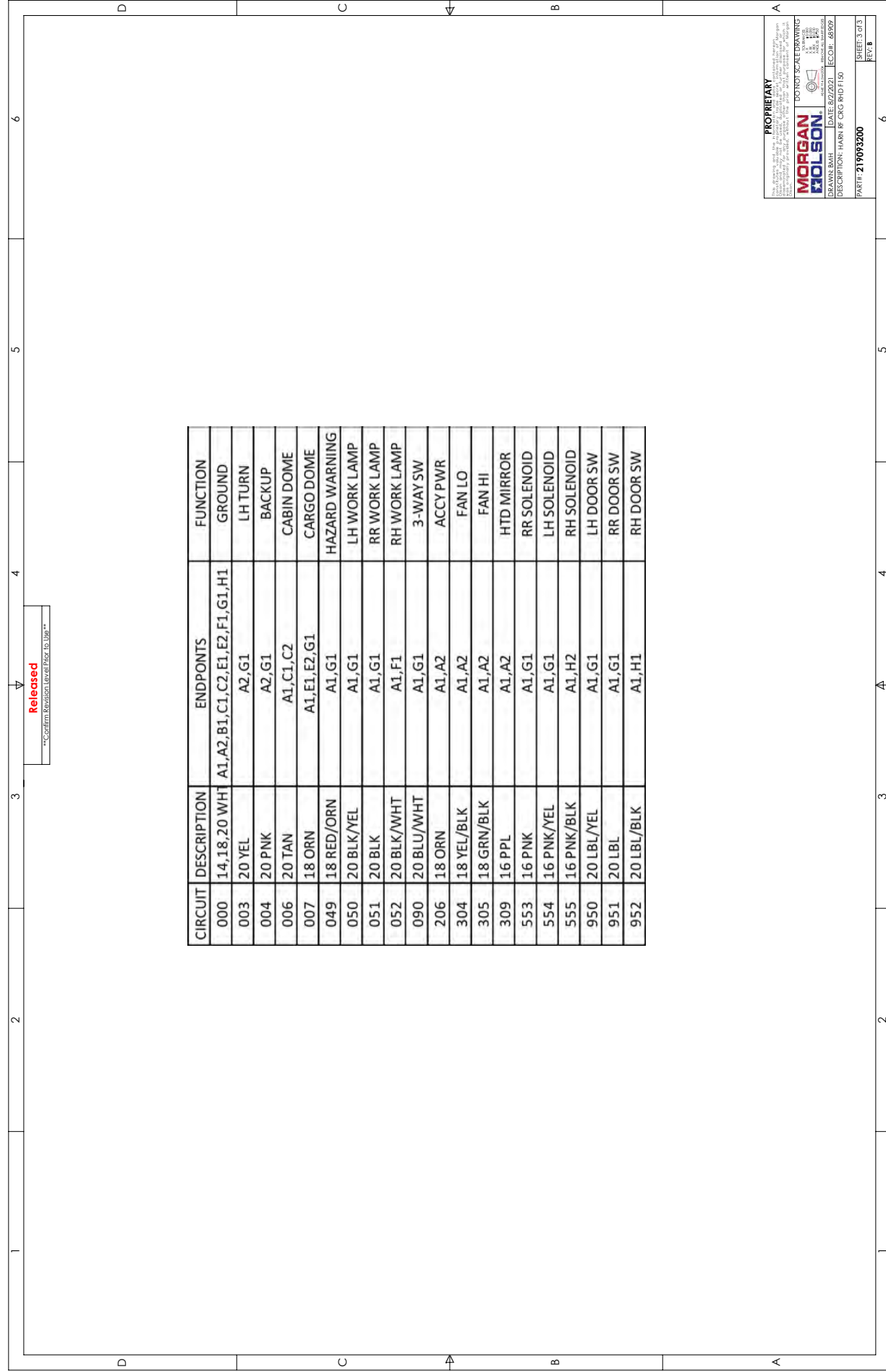

Section 13-2 Wiring Harness Diagrams

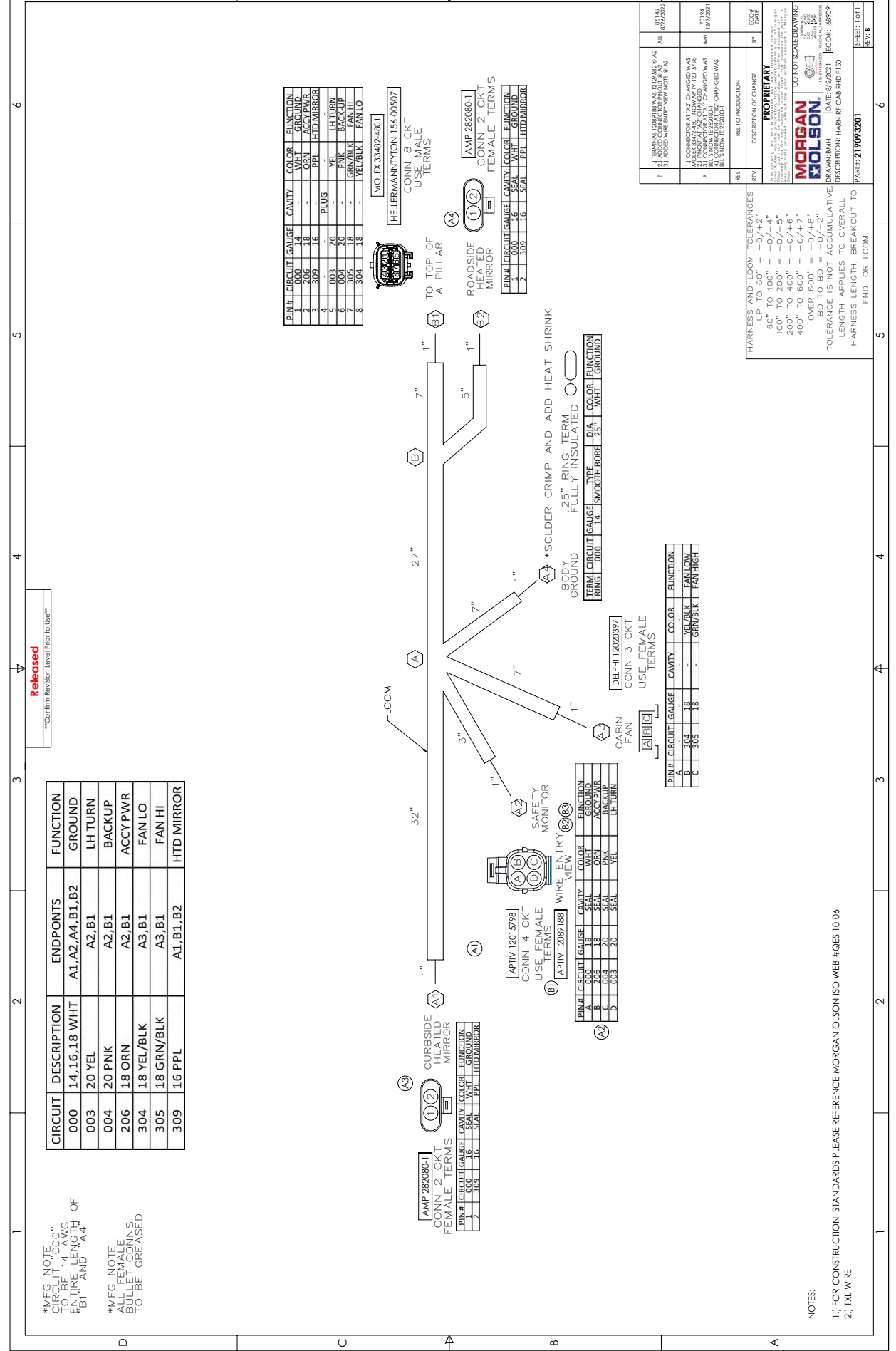



CABLE - CAMERA TO MONITOR
P/N 49013476 12'
P/N 49013477 22'



CABLE - SPEAKER WIRING
P/N 49013959

Section 13-2 Wiring Harness Diagrams

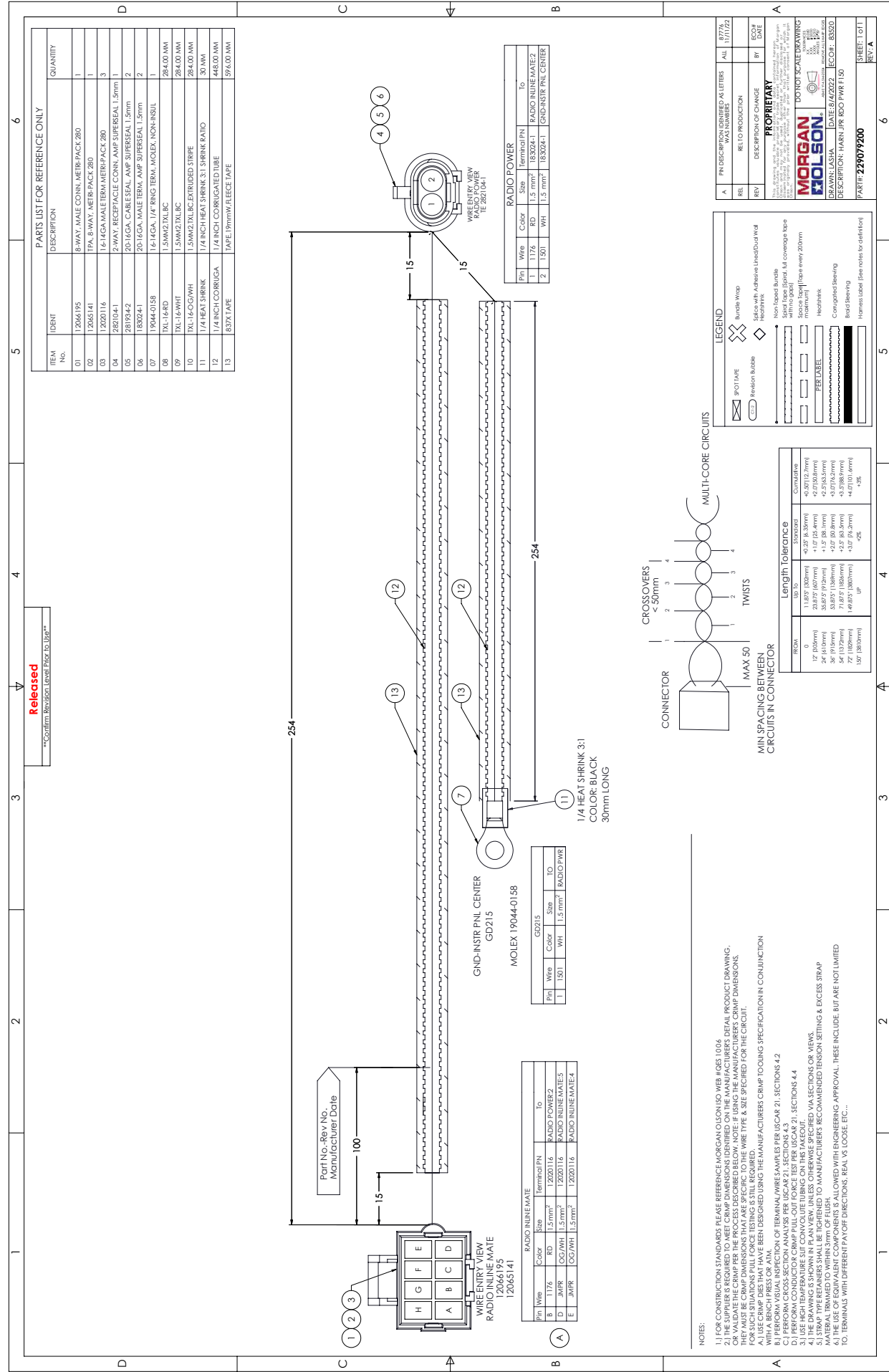

Section 13-2 Wiring Harness Diagrams

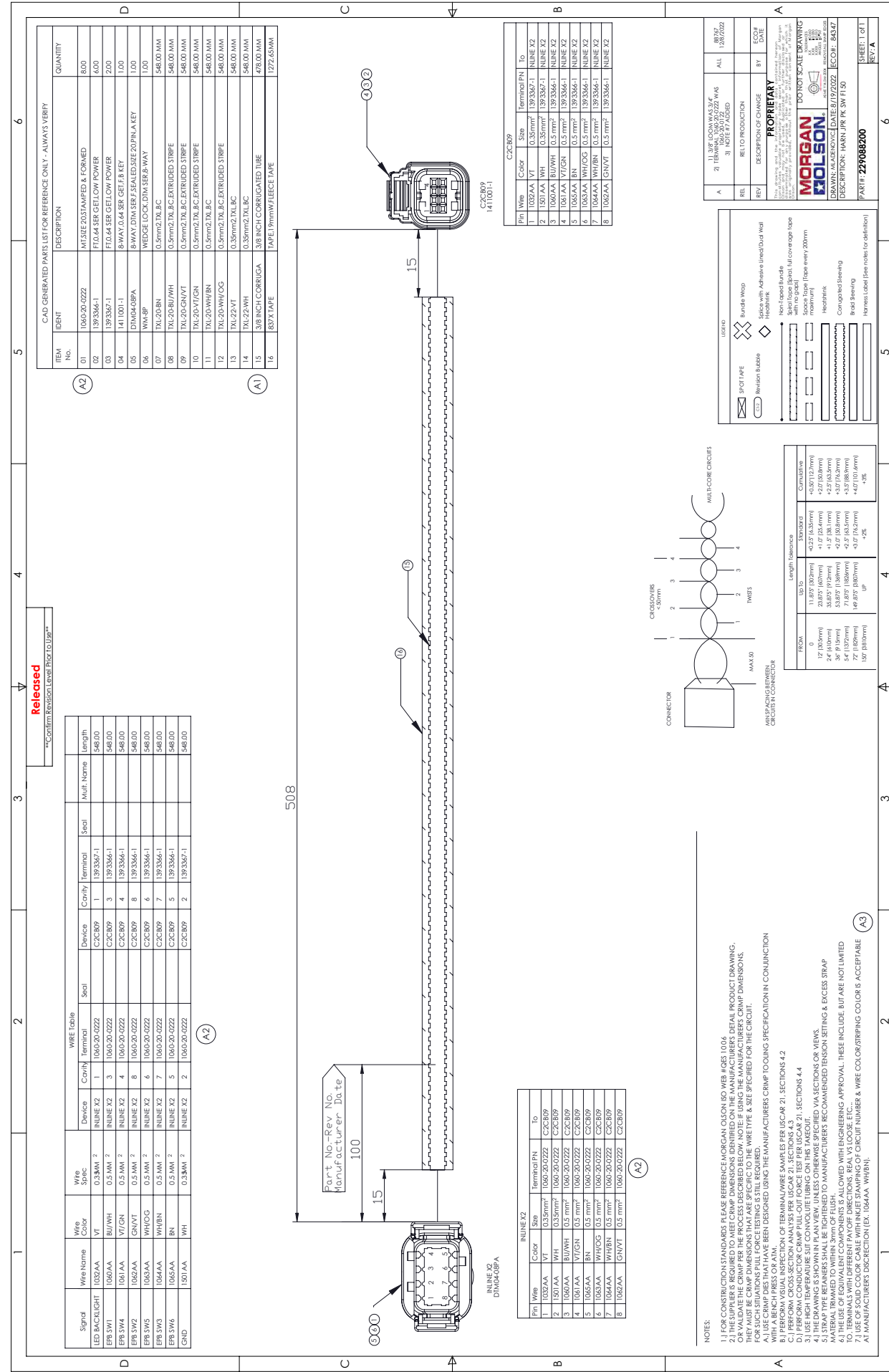

14 - Schematic Diagrams

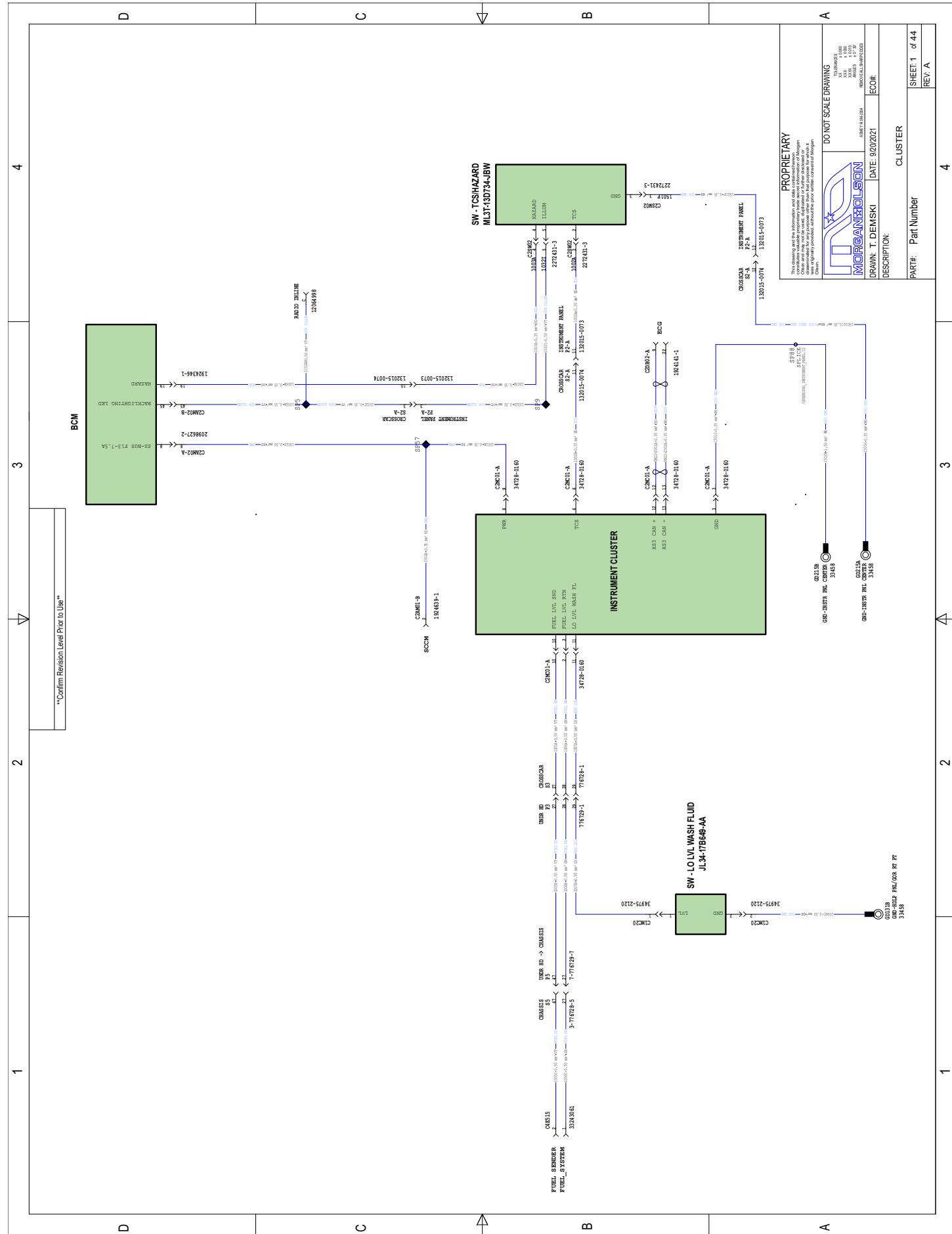

14 - Schematic Diagrams

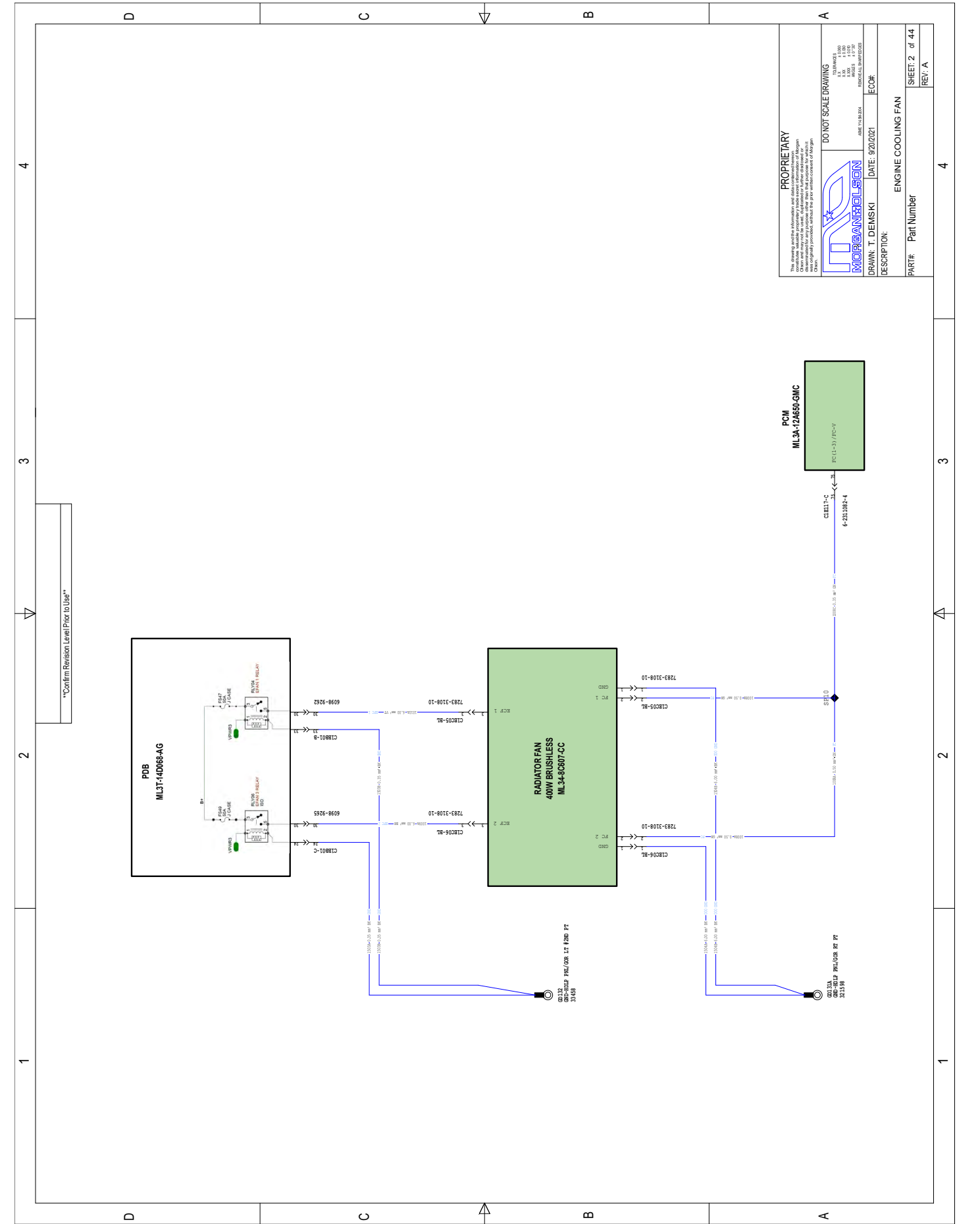

14 - Schematic Diagrams

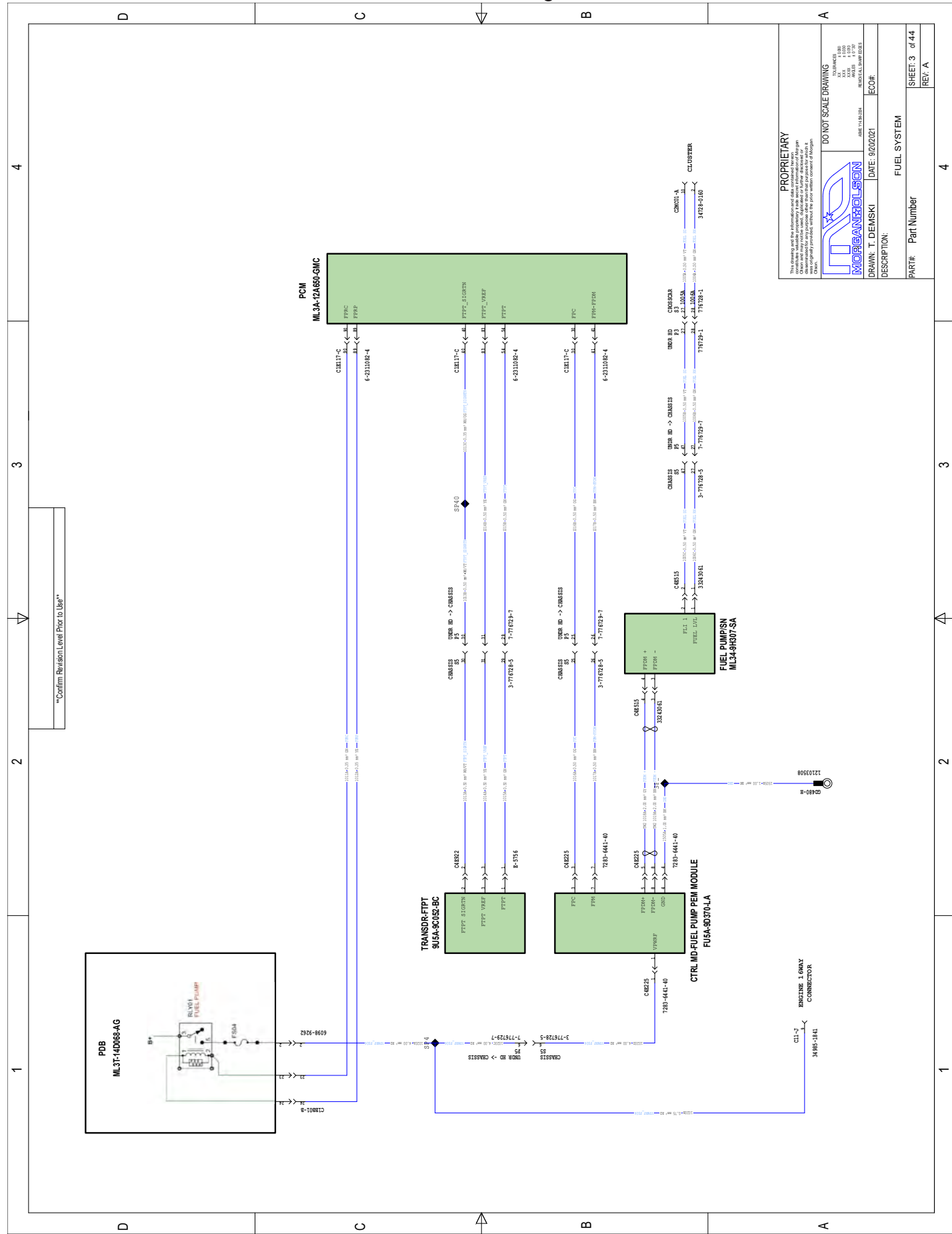

14 - Schematic Diagrams

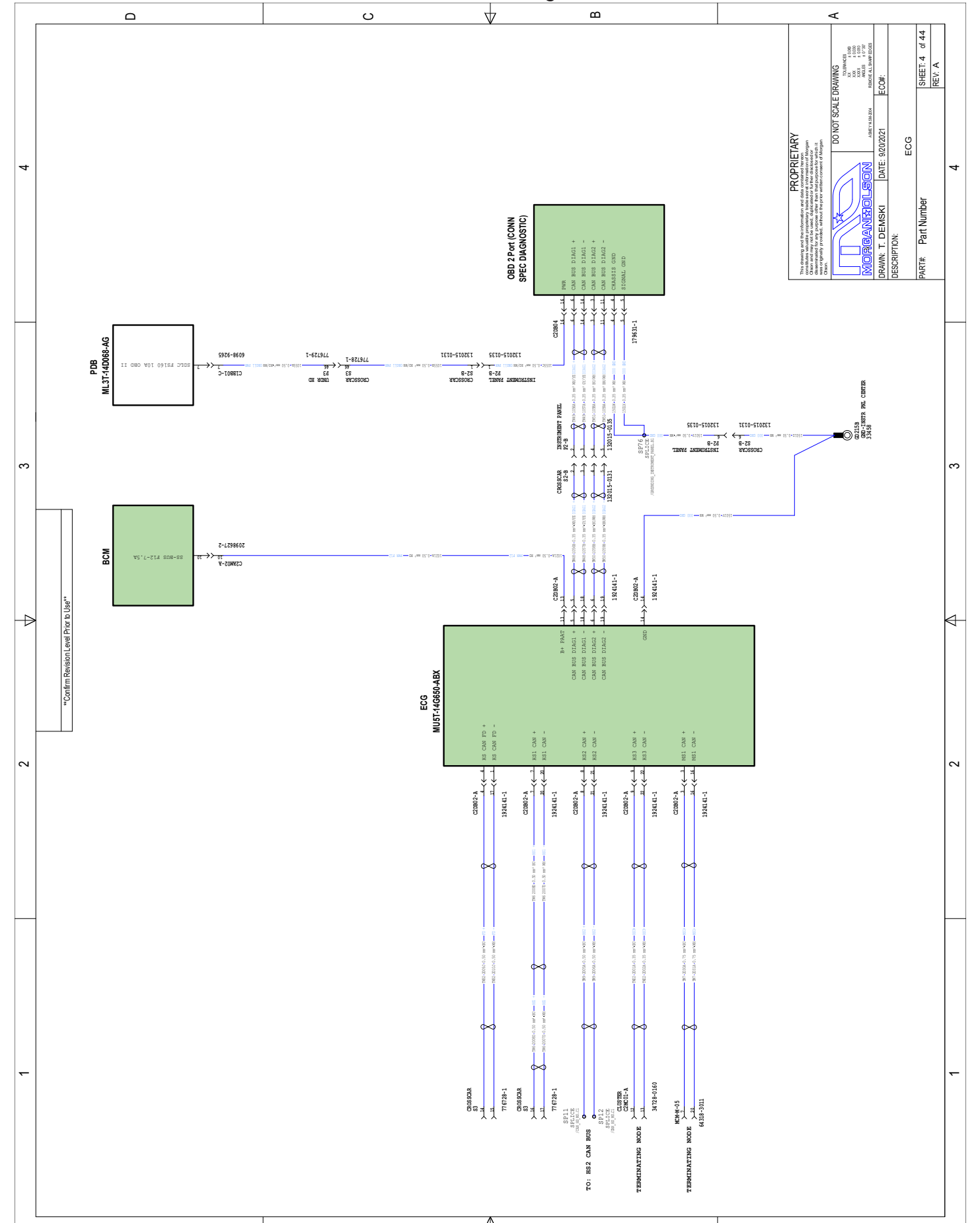

14 - Schematic Diagrams

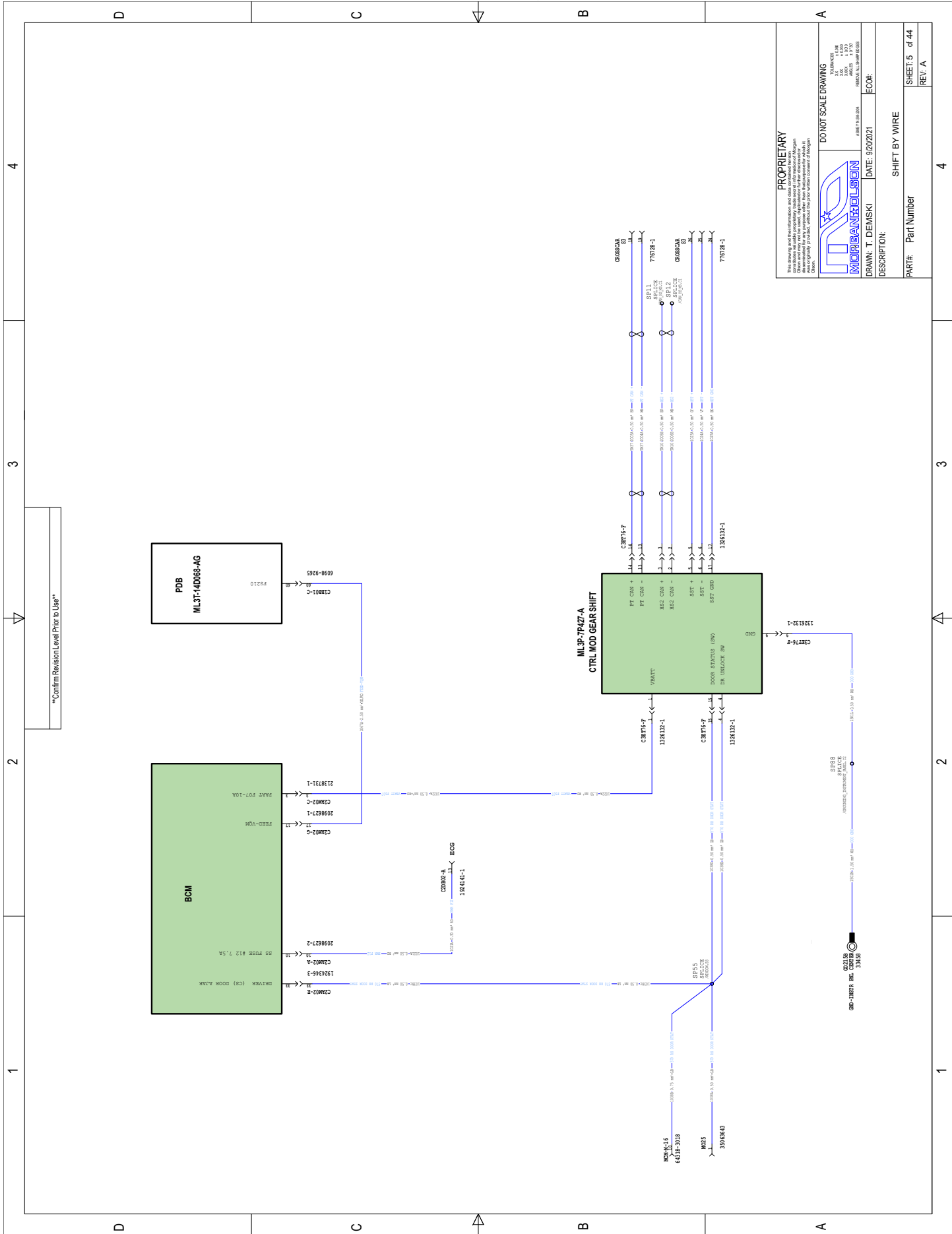

PROPRIETARY
 This drawing and the information contained herein are the property of MORAN/ROLLSON. It is to be used only for the vehicle or component for which it was specifically prepared. It is not to be used for any other purpose without the express written consent of MORAN/ROLLSON.

MORAN/ROLLSON
 1234567890
 1234567890
 1234567890
 1234567890

DO NOT SCALE DRAWING
 DIMENSIONS
 IN MILLIMETERS
 UNLESS OTHERWISE SPECIFIED
 TOLERANCES
 FRACTIONS DECIMALS
 .0005 .001 .002 .005 .010 .015 .030 .050 .100 .150 .300 .500 .750
 .001 .002 .005 .010 .015 .030 .050 .100 .150 .300 .500 .750
 .002 .005 .010 .015 .030 .050 .100 .150 .300 .500 .750 .1500 .3000 .4500 .6000 .9000
 UNLESS OTHERWISE SPECIFIED
 DIMENSIONS ARE IN MILLIMETERS UNLESS OTHERWISE SPECIFIED

DESCRIPTION: SHIFT BY WIRE
DATE: 9/20/2021
ECOH:
DRAWN: T. DEMSKI
DATE: 9/20/2021
ECOH:

PART#: Part Number
DESCRIPTION: SHIFT BY WIRE
DATE: 9/20/2021
ECOH:

SHEET: 5 of 44
REV: A

14 - Schematic Diagrams

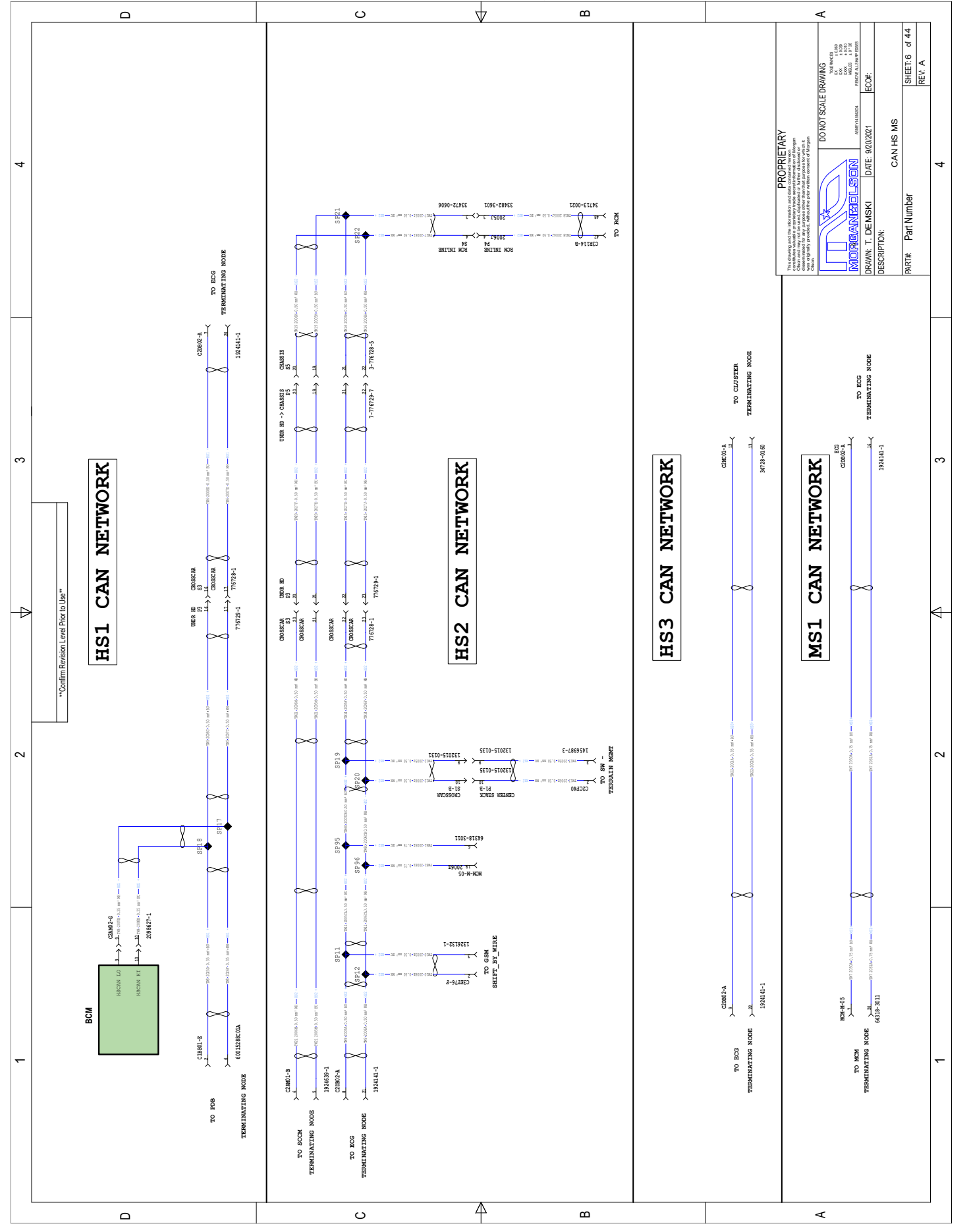

PROPRIETARY
 This drawing and the information contained herein are the property of MORAN/ROLLSON. It is to be used only for the vehicle or component for which it was specifically prepared. It is not to be used for any other purpose without the express written consent of MORAN/ROLLSON.

MORAN/ROLLSON
 1234567890
 1234567890
 1234567890
 1234567890

DO NOT SCALE DRAWING
 DIMENSIONS
 IN MILLIMETERS
 UNLESS OTHERWISE SPECIFIED
 TOLERANCES
 FRACTIONS DECIMALS
 .0005 .001 .002 .005 .010 .015 .030 .050 .100 .150 .300 .500 .750
 .001 .002 .005 .010 .015 .030 .050 .100 .150 .300 .500 .750
 .002 .005 .010 .015 .030 .050 .100 .150 .300 .500 .750 .1500 .3000 .4500 .6000 .9000
 UNLESS OTHERWISE SPECIFIED
 DIMENSIONS ARE IN MILLIMETERS UNLESS OTHERWISE SPECIFIED

DESCRIPTION: CAN HS MS
DATE: 9/20/2021
ECOH:
DRAWN: T. DEMSKI
DATE: 9/20/2021
ECOH:

PART#: Part Number
DESCRIPTION: CAN HS MS
DATE: 9/20/2021
ECOH:

SHEET: 6 of 44
REV: A

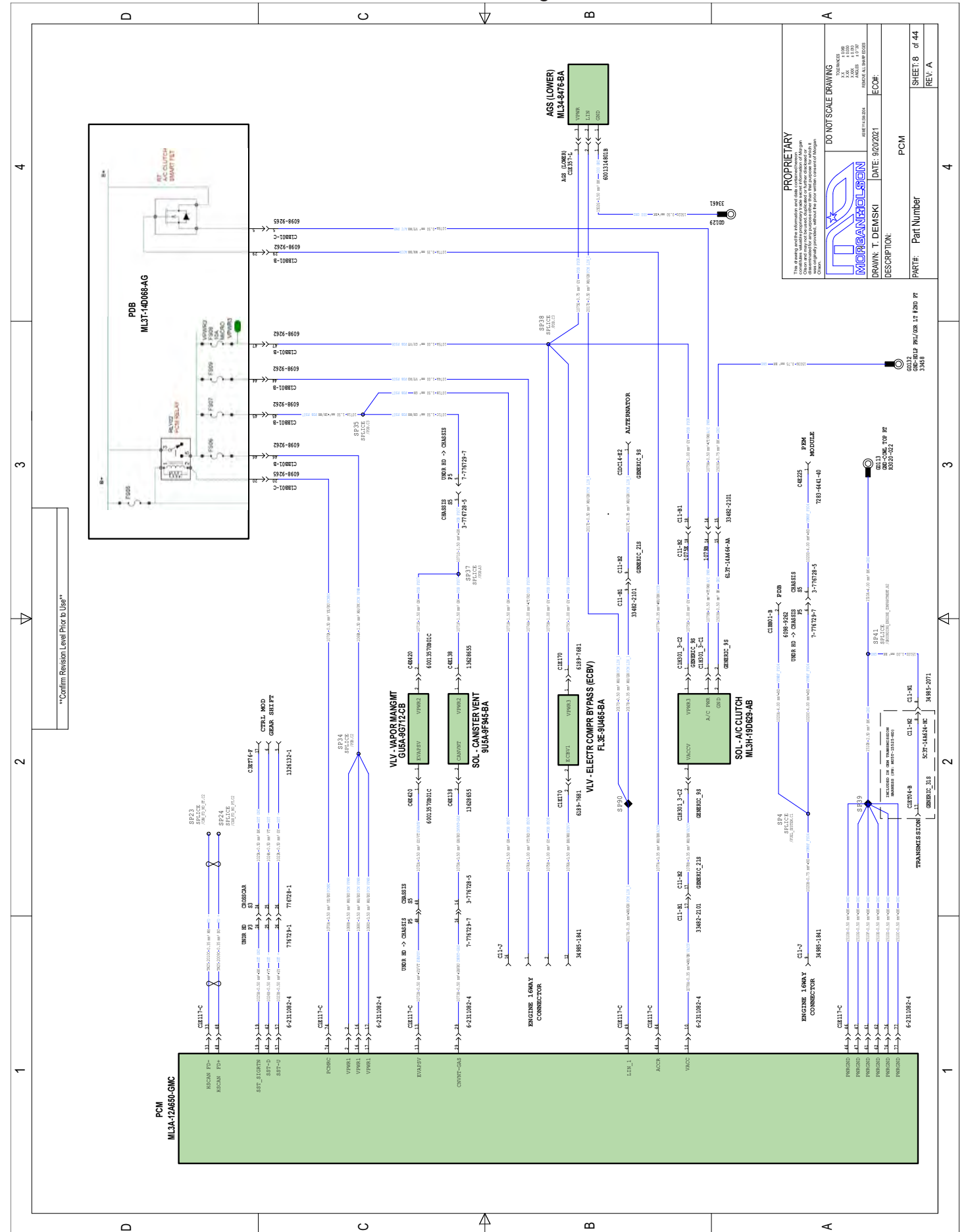
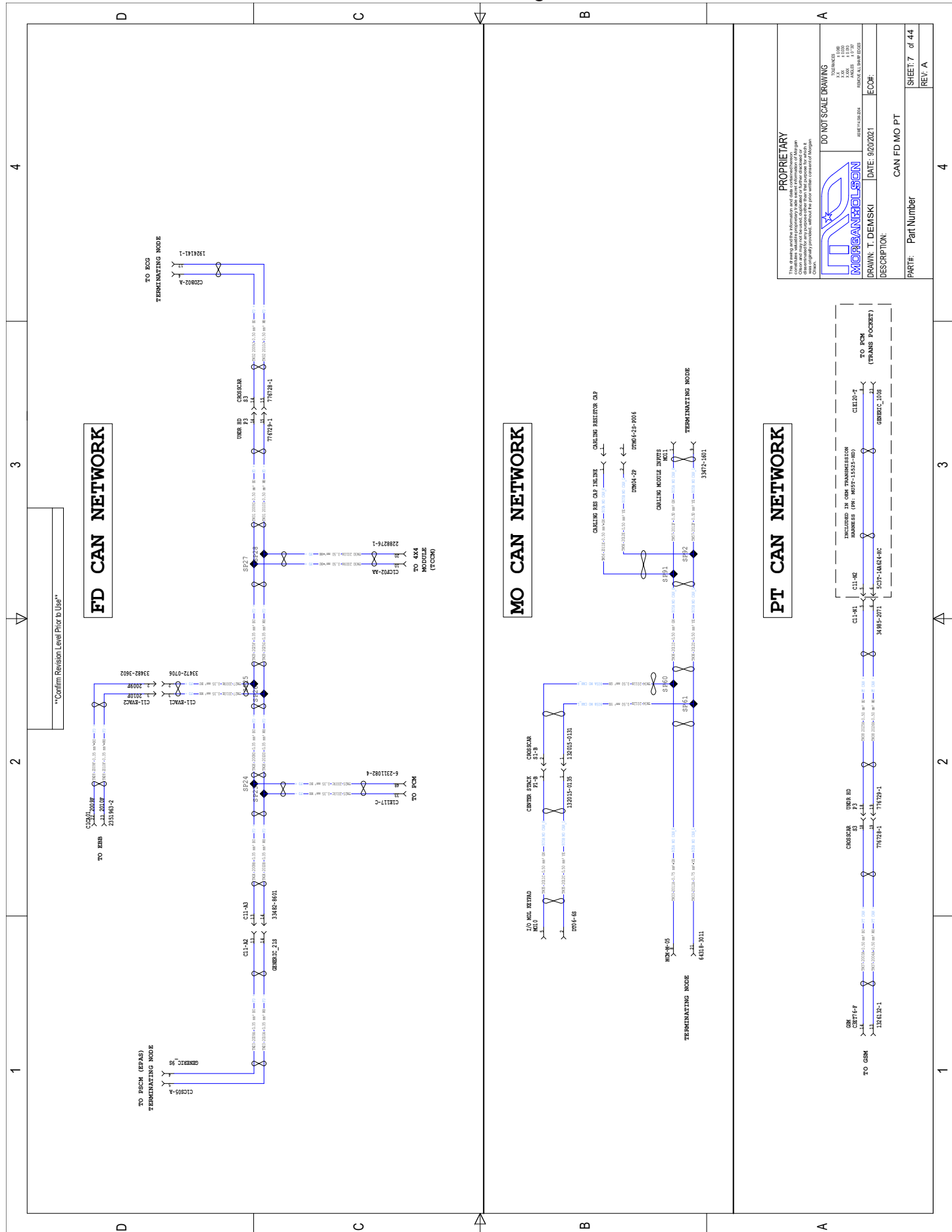

14 - Schematic Diagrams

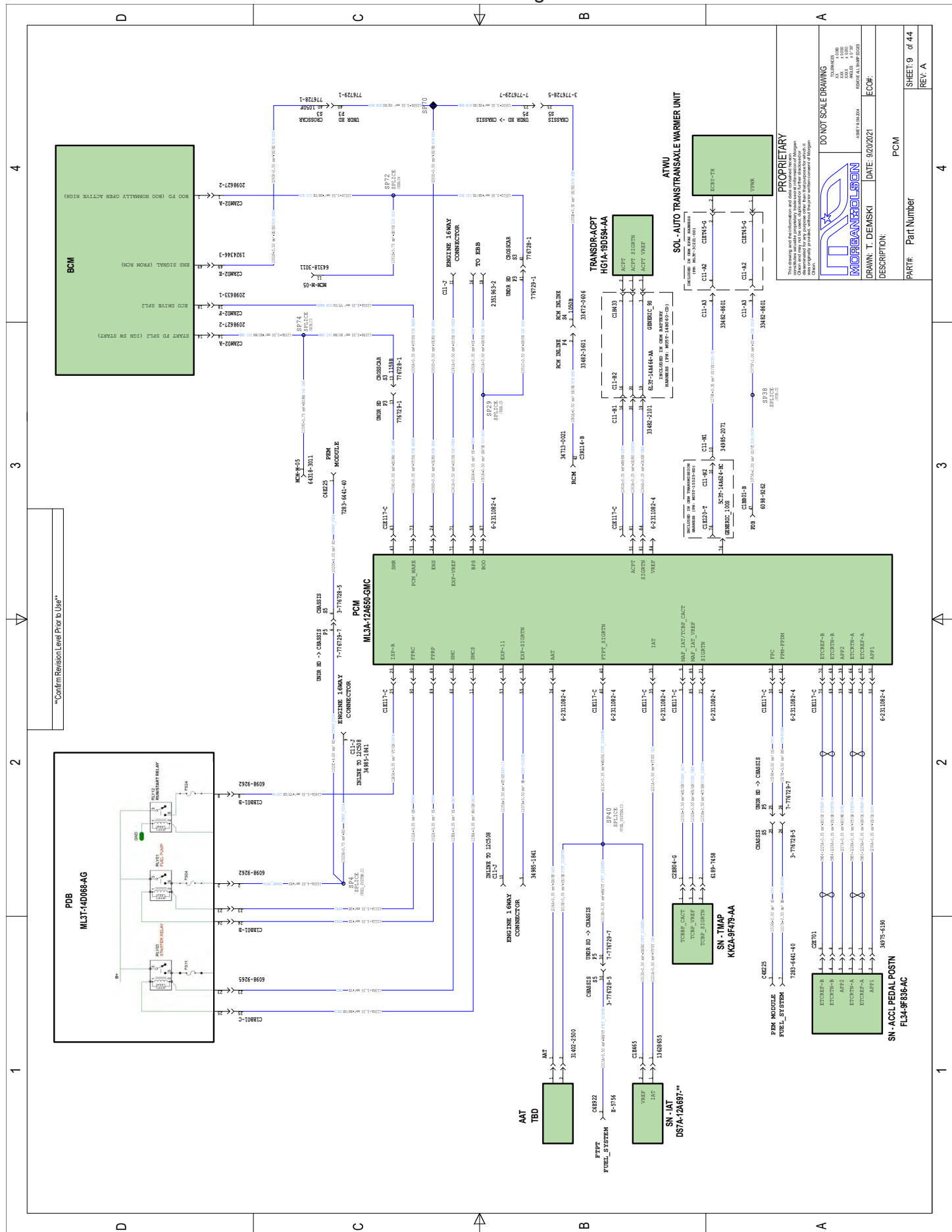

14 - Schematic Diagrams

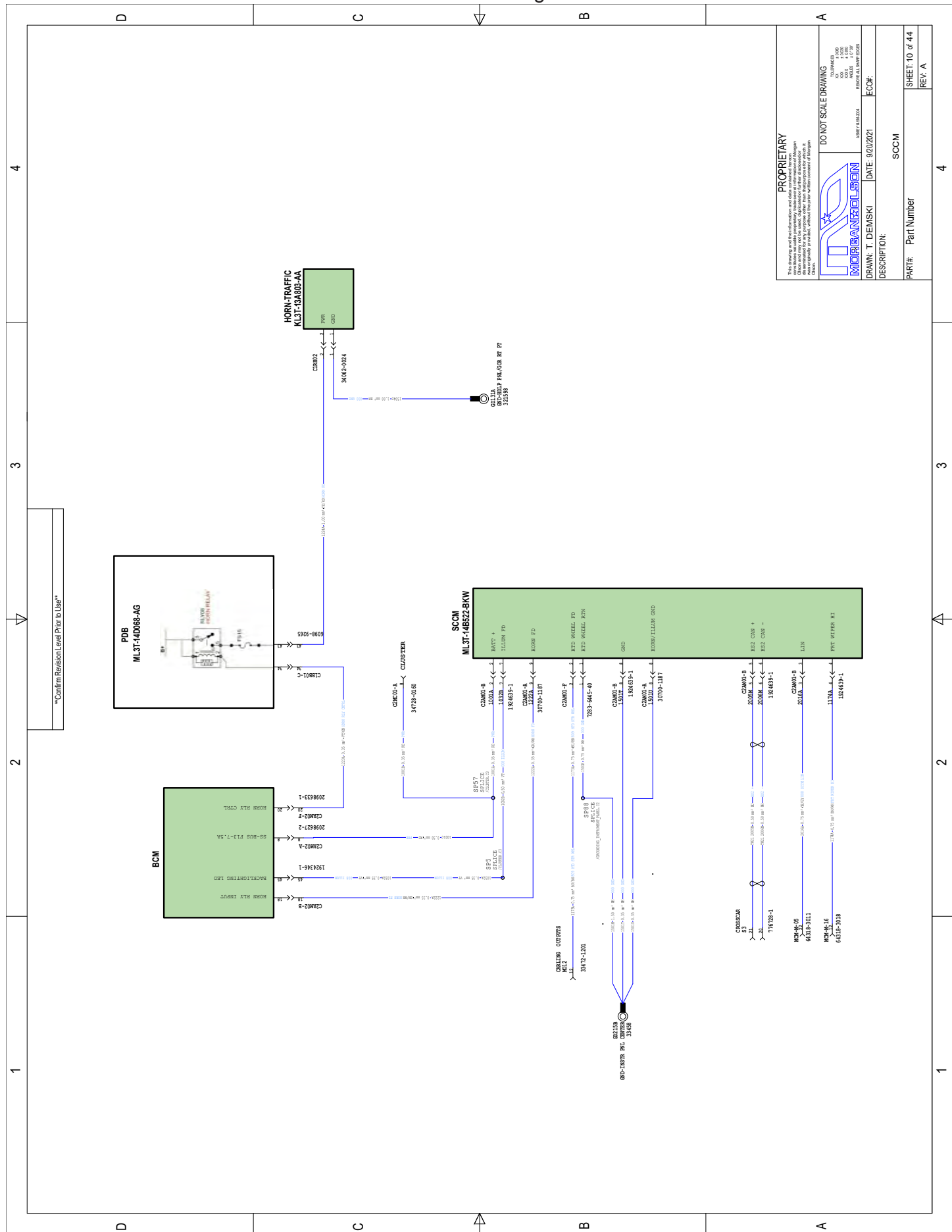

14 - Schematic Diagrams

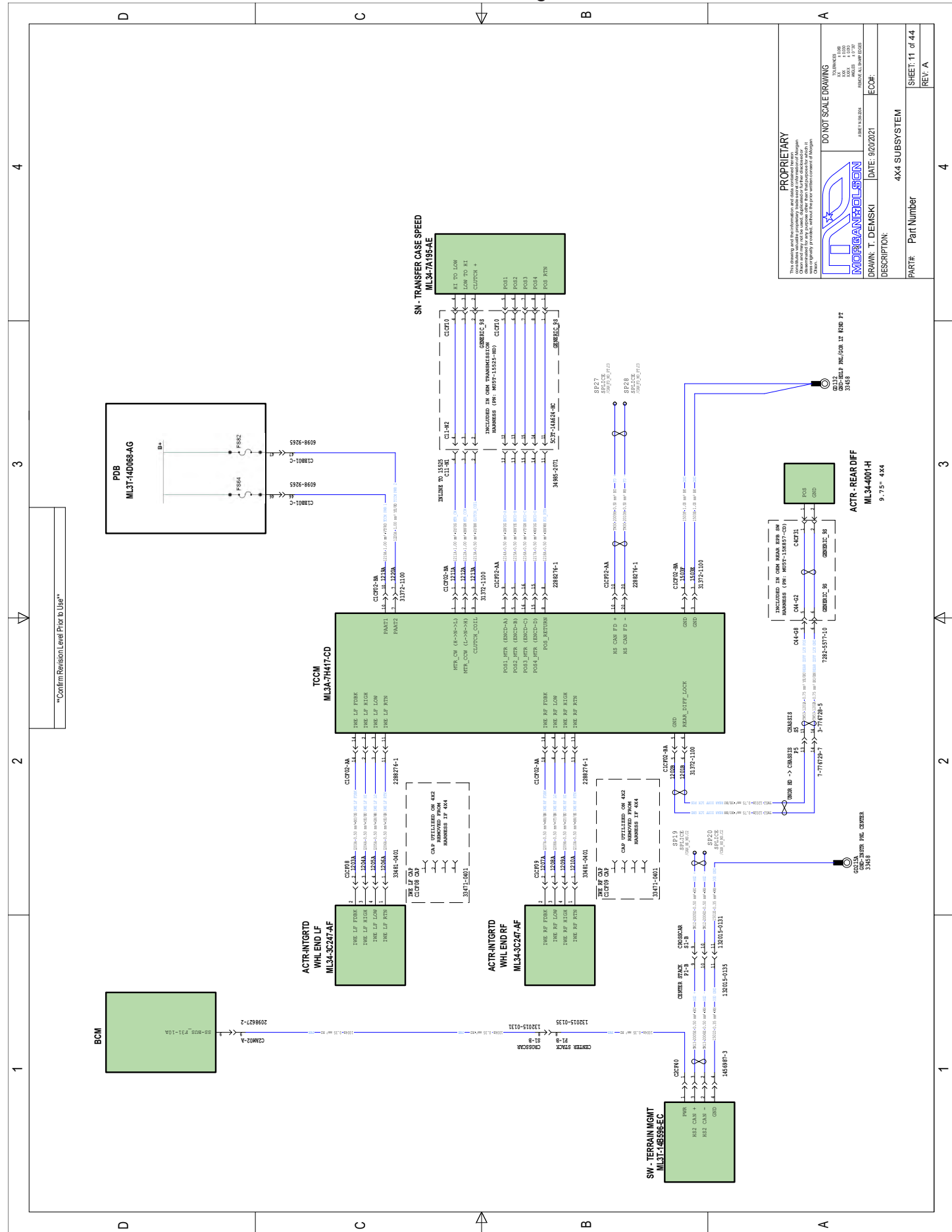

PROPRIETARY
 This drawing and its information are the property of Morgan大通. It is to be used only for the vehicle, make and model for which it was prepared. It is not to be reproduced, stored in a retrieval system, or transmitted in any form or by any means, electronic, mechanical, photocopying, recording, or by any information storage and retrieval system, without the prior written consent of Morgan大通.

MORGAN大通
 DRAWN: T. DEMSKI DATE: 9/20/2021 ECU#:
 DESCRIPTION: 4X4 SUBSYSTEM
 PART#: Part Number
 SHEET: 11 of 44
 REV: A

14 - Schematic Diagrams

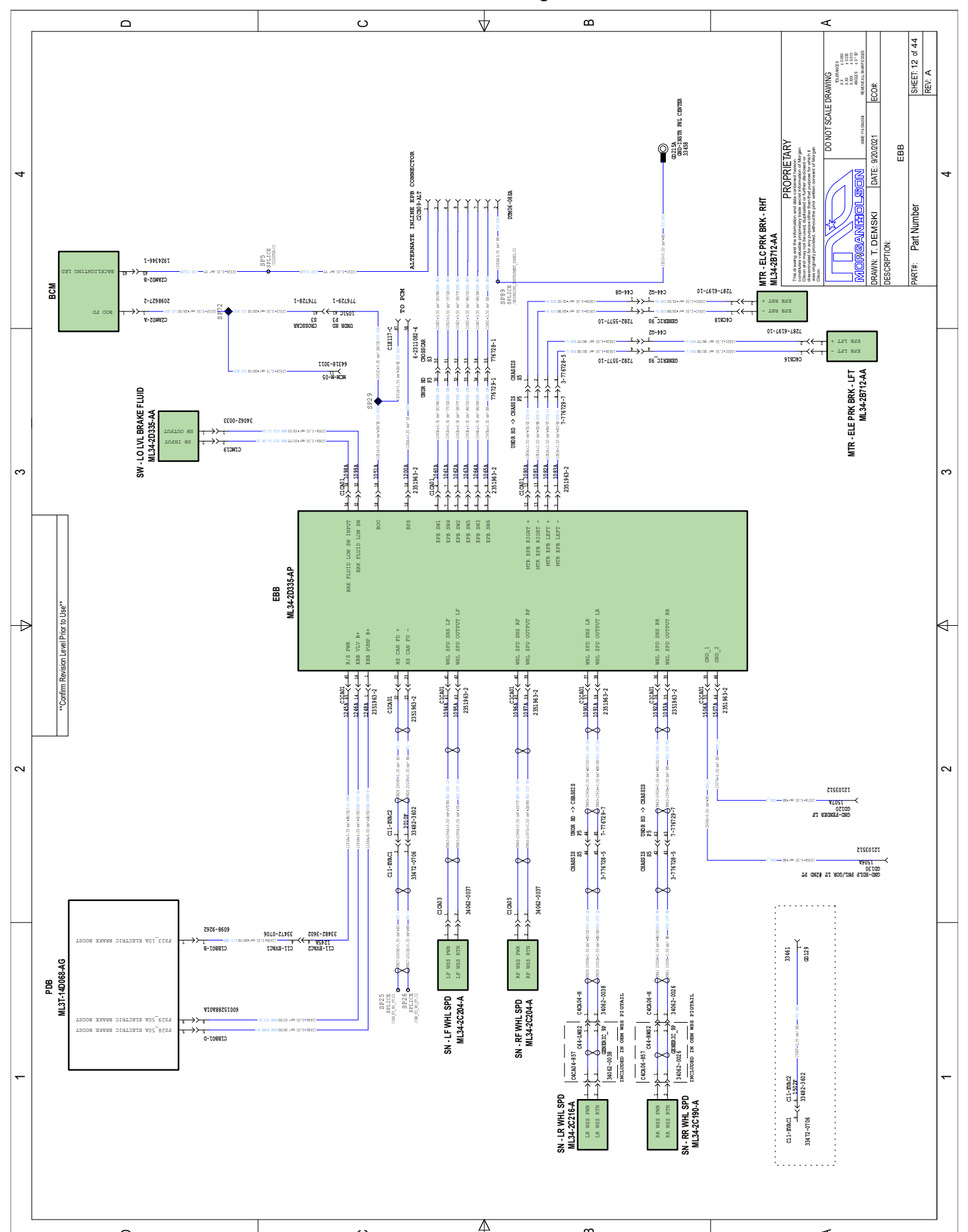

PROPRIETARY
 This drawing and its information are the property of Morgan大通. It is to be used only for the vehicle, make and model for which it was prepared. It is not to be reproduced, stored in a retrieval system, or transmitted in any form or by any means, electronic, mechanical, photocopying, recording, or by any information storage and retrieval system, without the prior written consent of Morgan大通.

MORGAN大通
 DRAWN: T. DEMSKI DATE: 9/20/2021 ECU#:
 DESCRIPTION: EBB
 PART#: Part Number
 SHEET: 12 of 44
 REV: A

14 - Schematic Diagrams

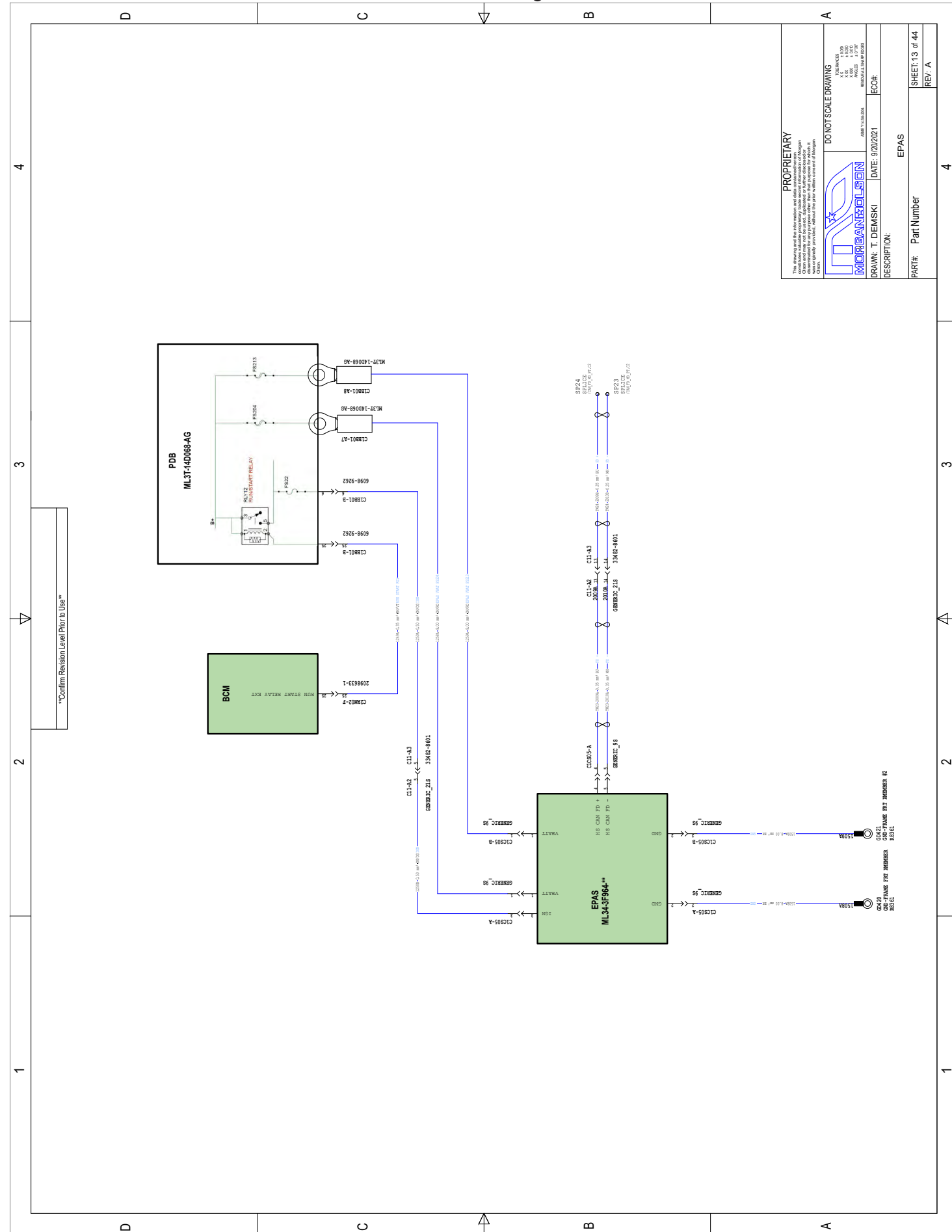

14 - Schematic Diagrams

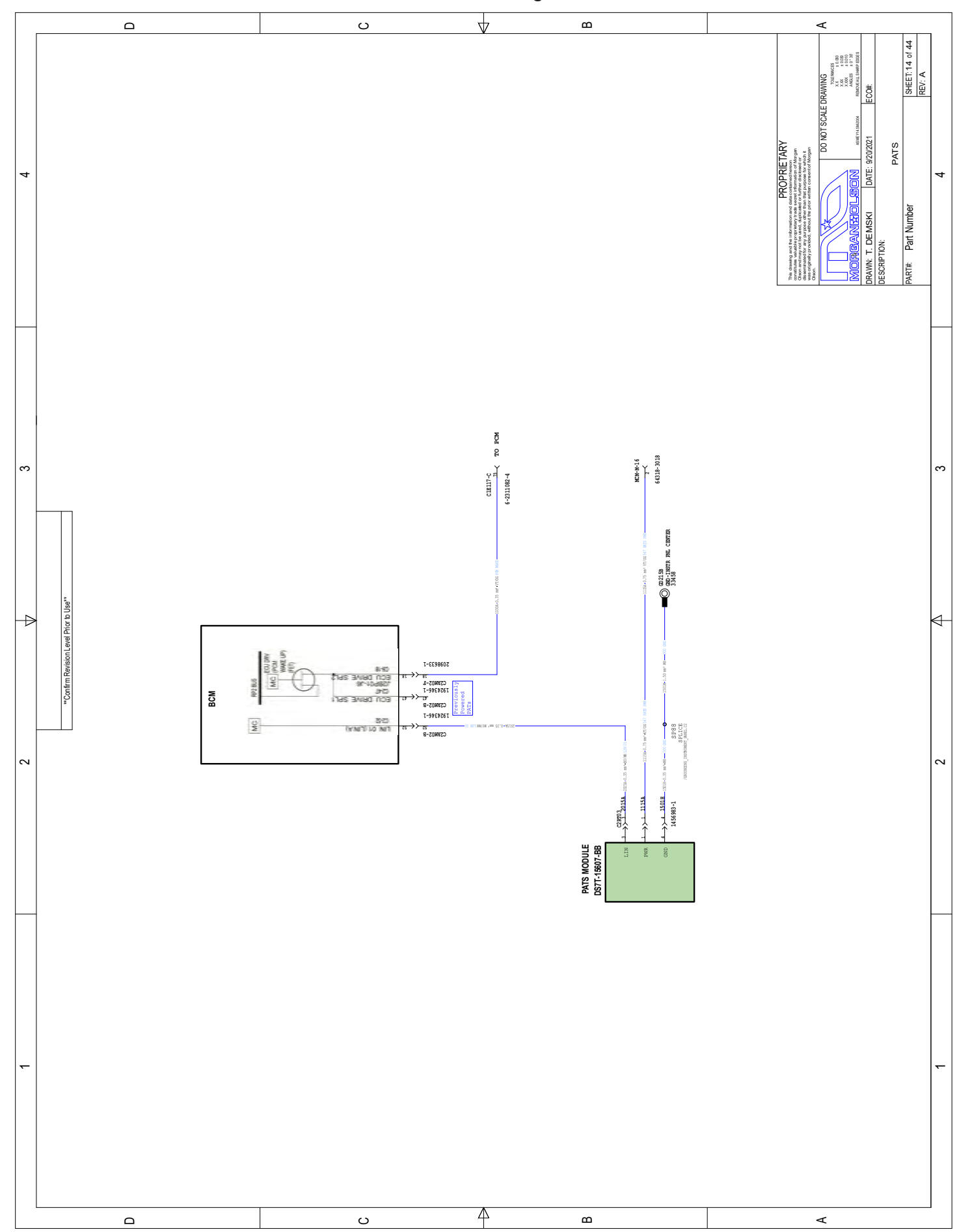

14 - Schematic Diagrams

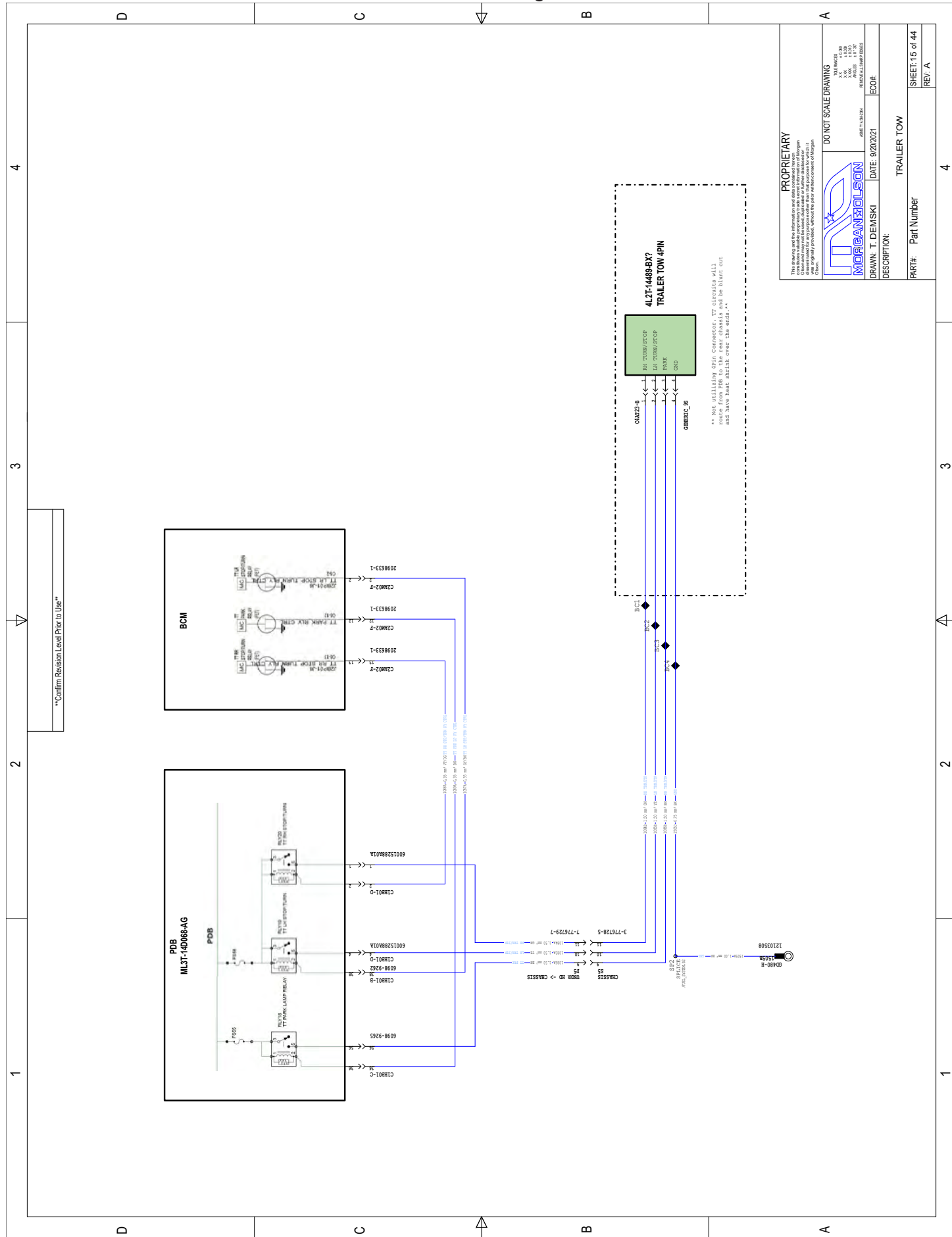

14 - Schematic Diagrams

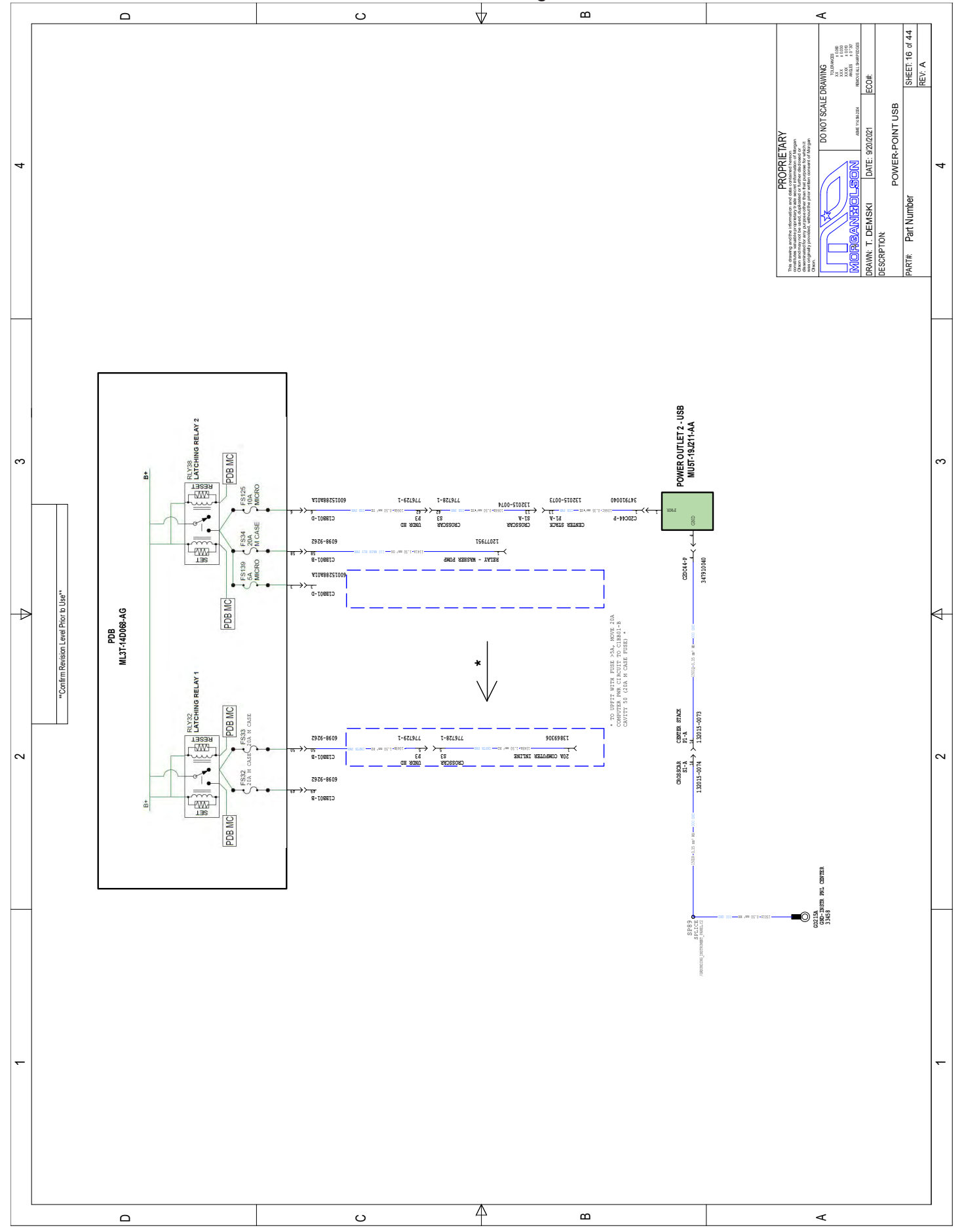

14 - Schematic Diagrams

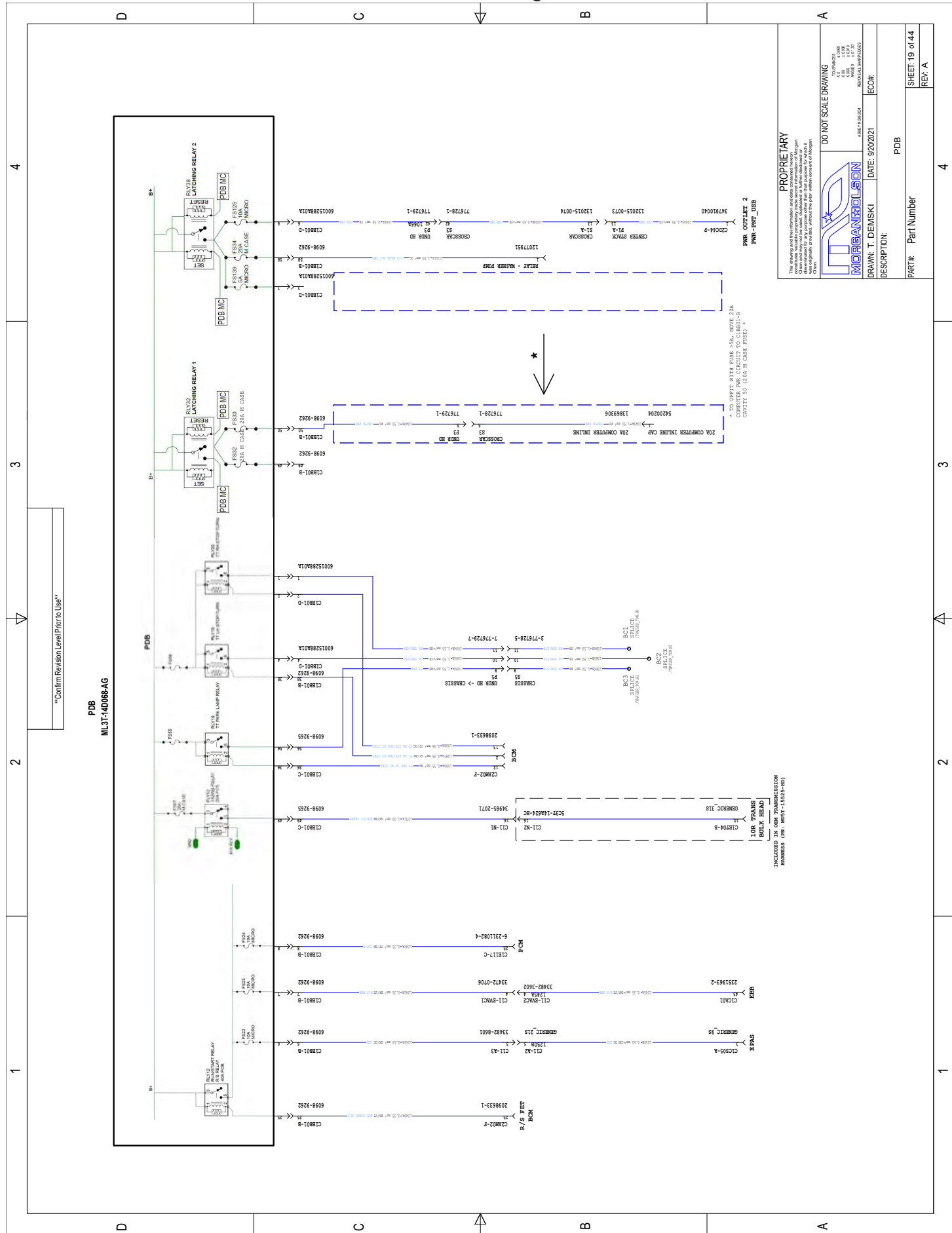

14 - Schematic Diagrams

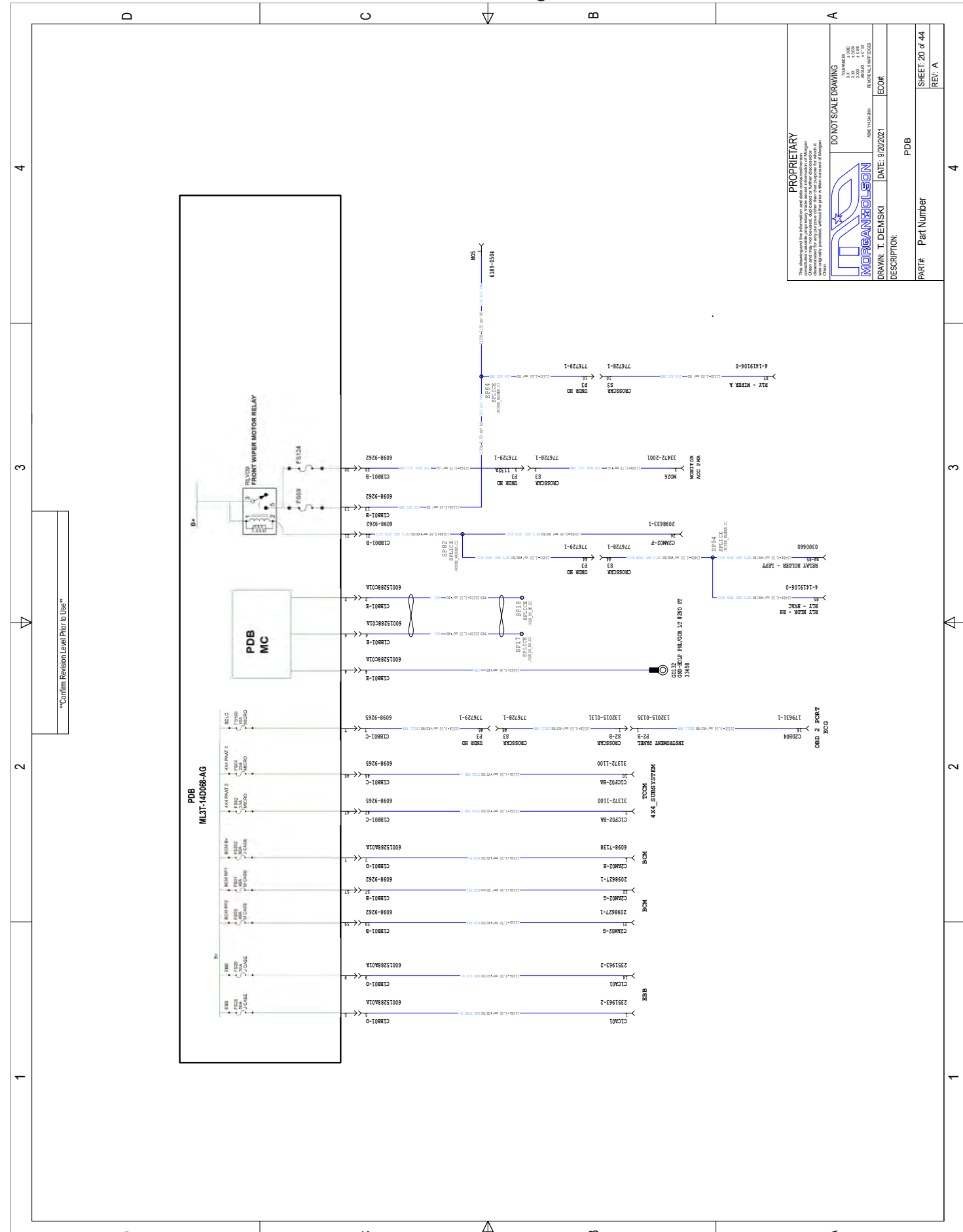

14 - Schematic Diagrams

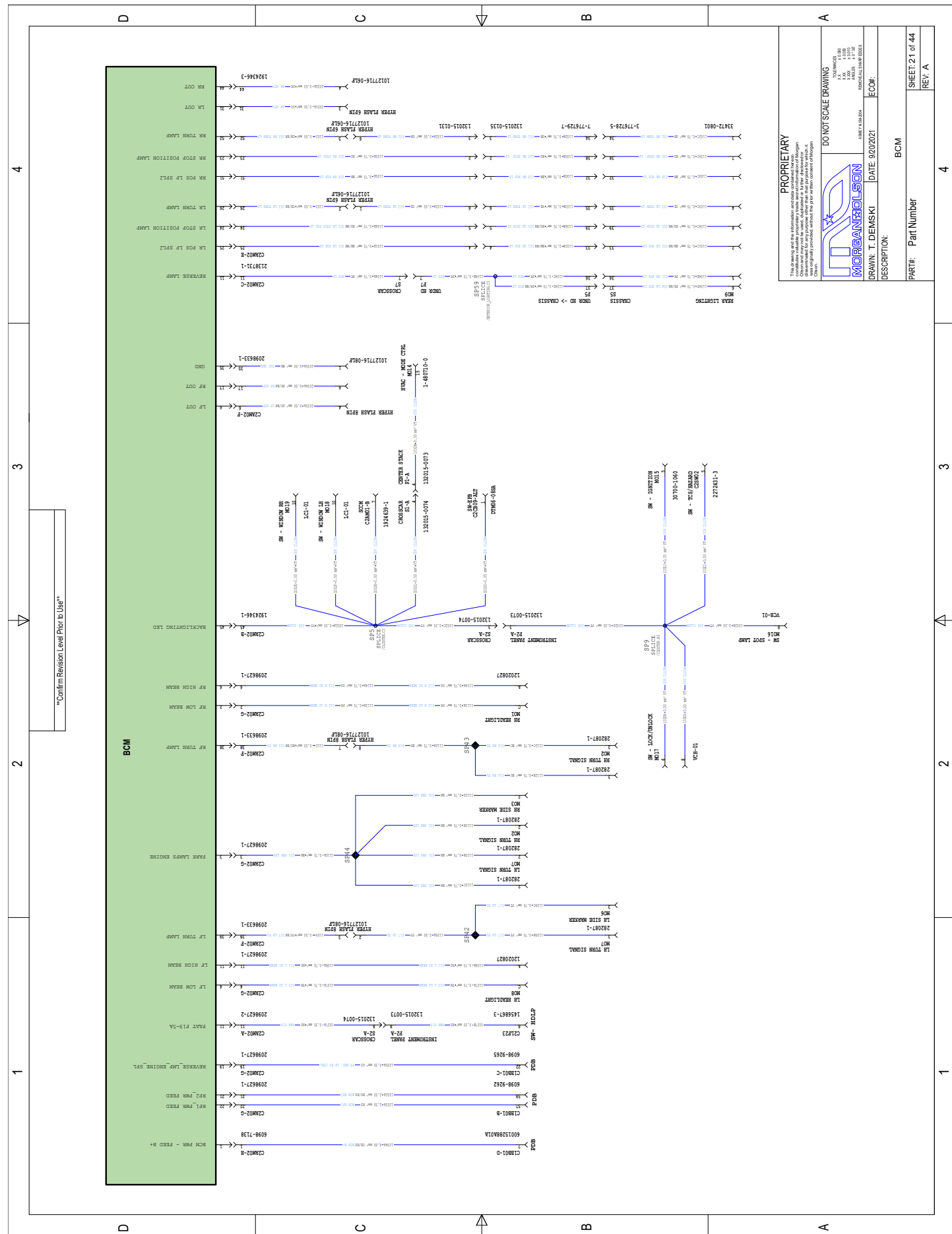

14 - Schematic Diagrams

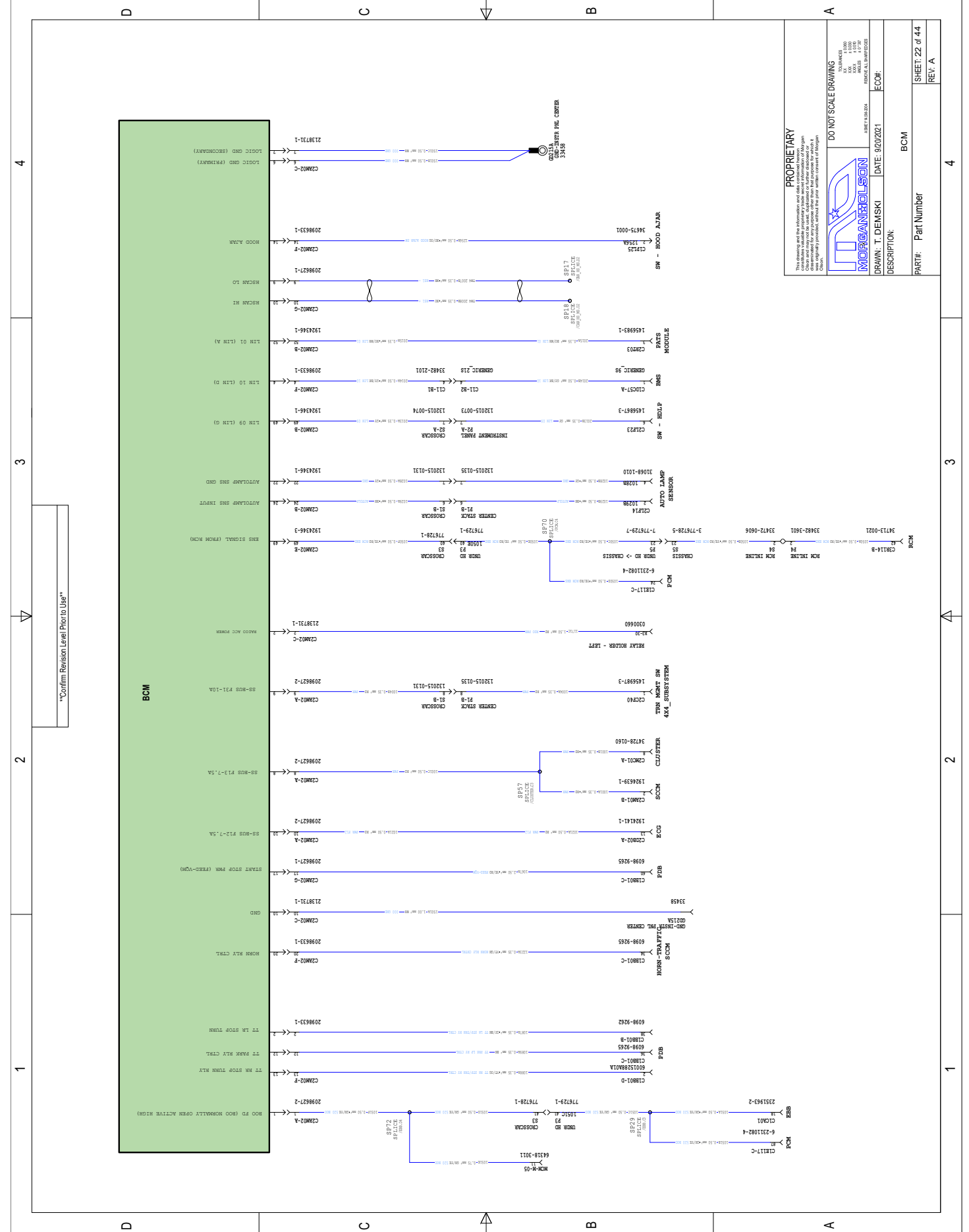

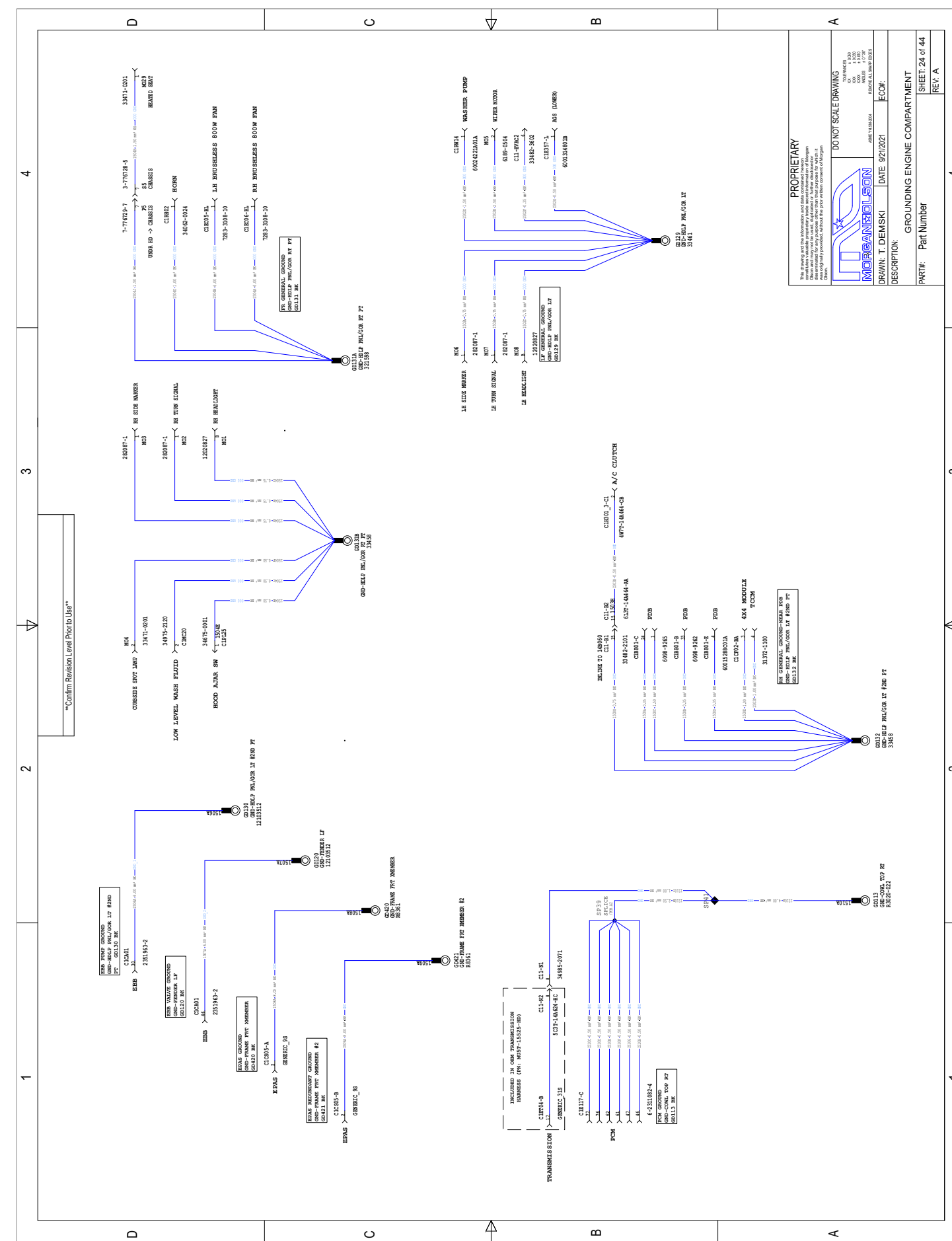
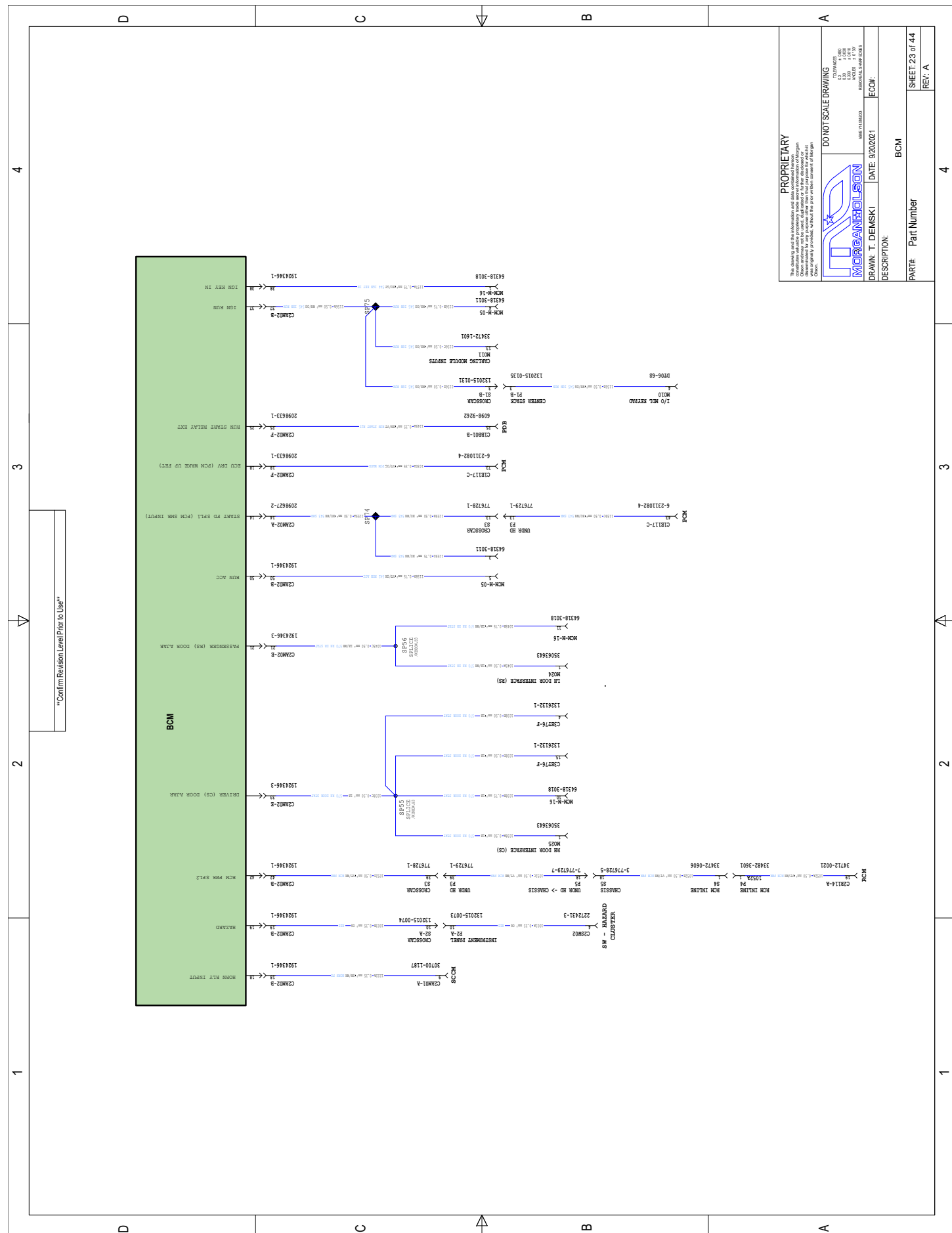

14 - Schematic Diagrams

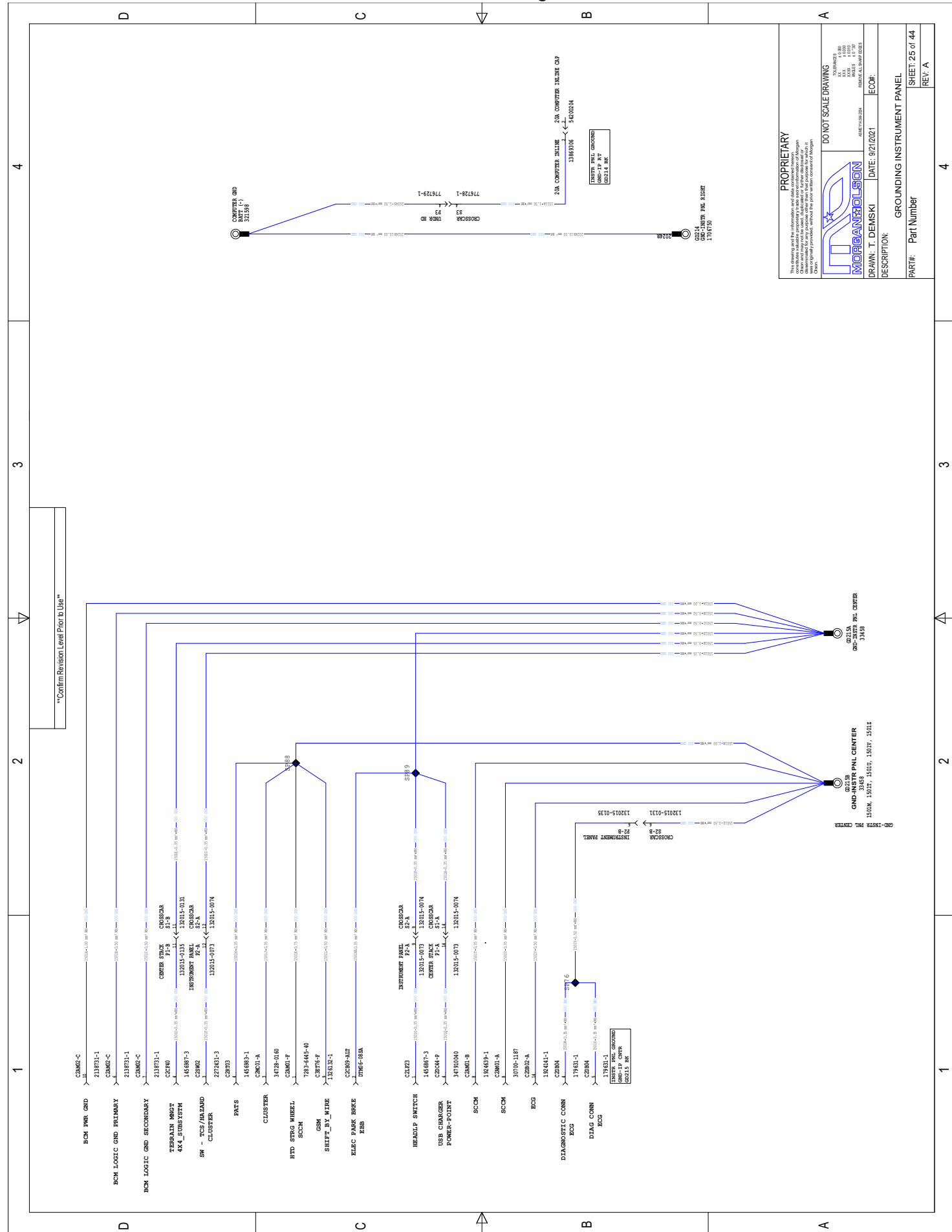

14 - Schematic Diagrams

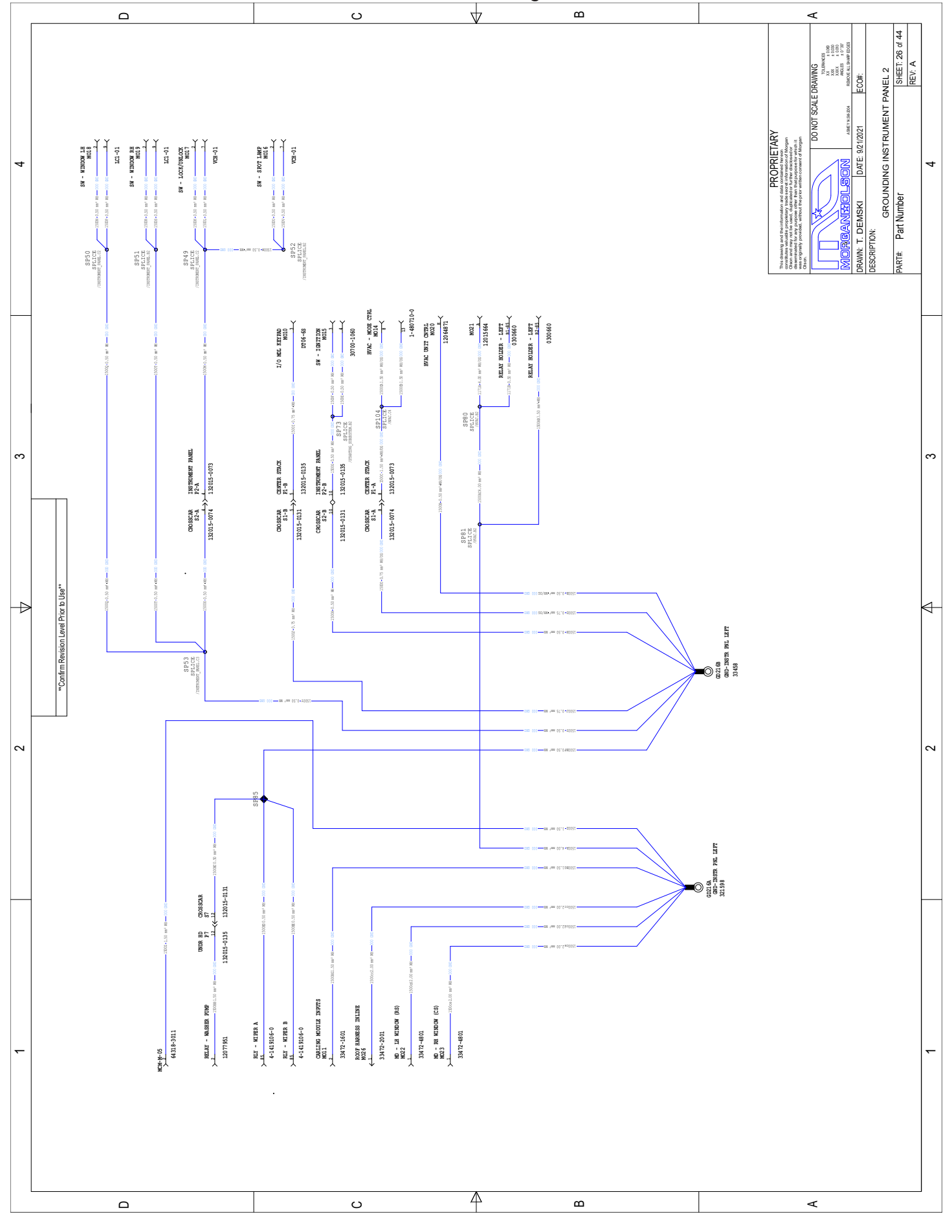

14 - Schematic Diagrams

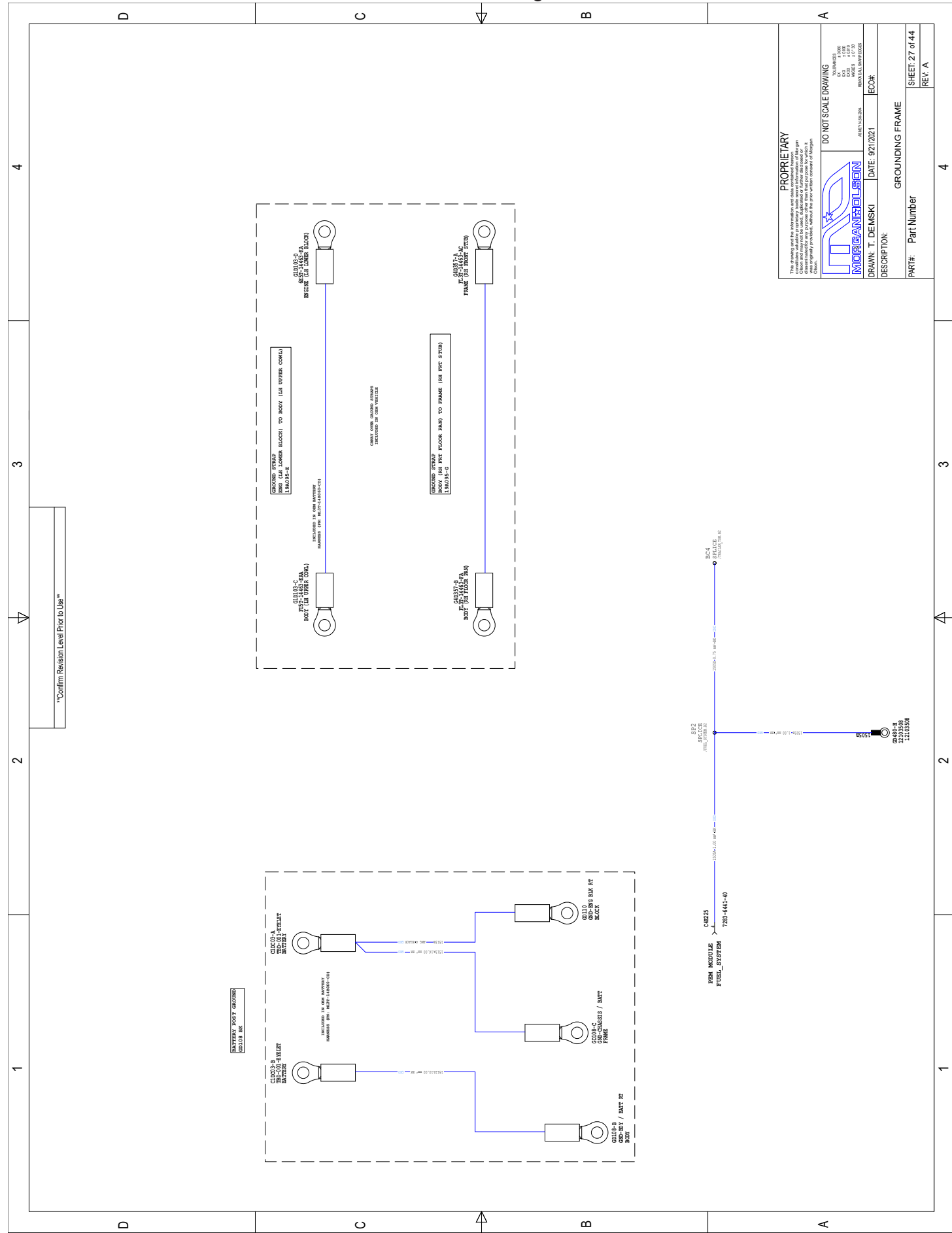

14 - Schematic Diagrams

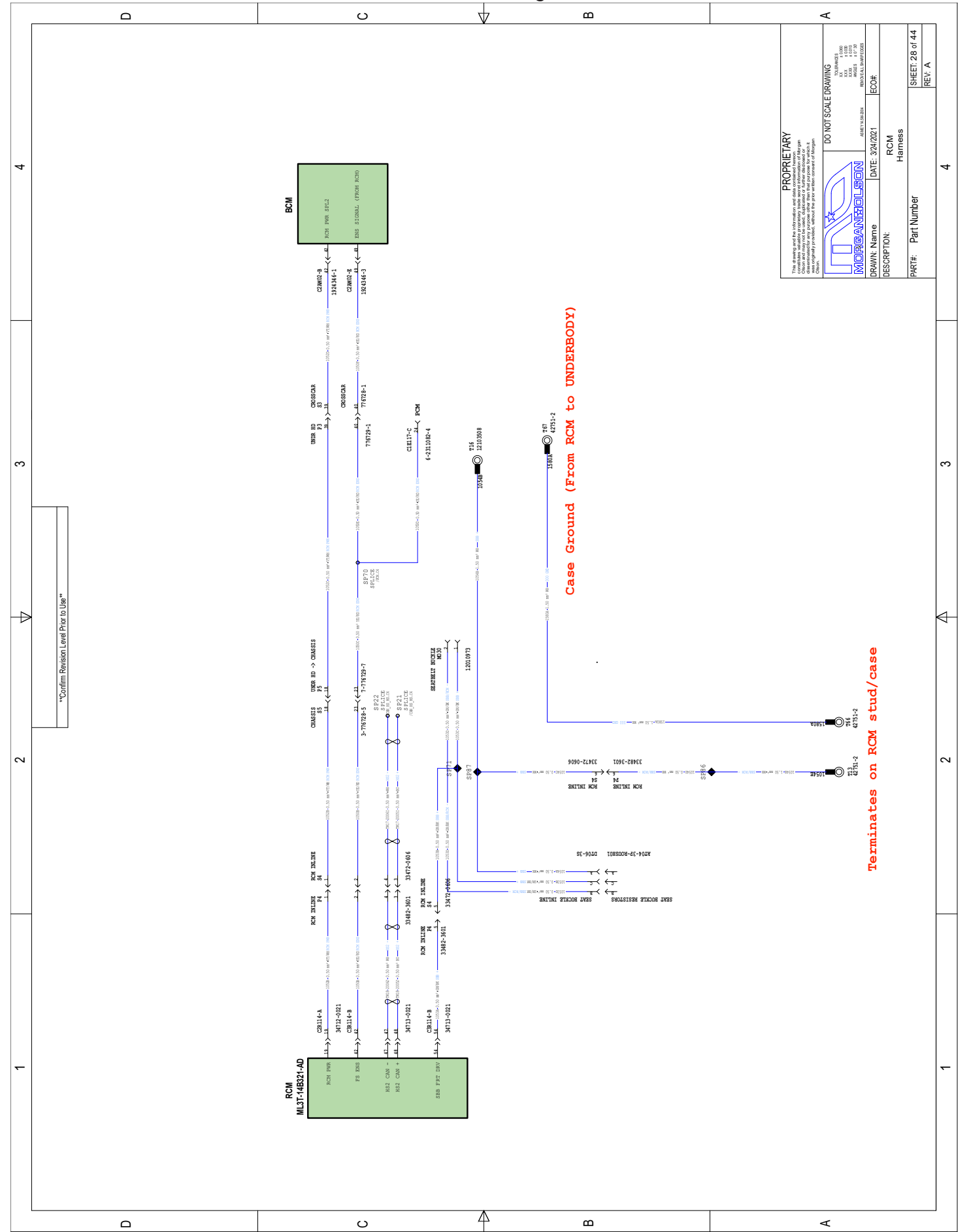

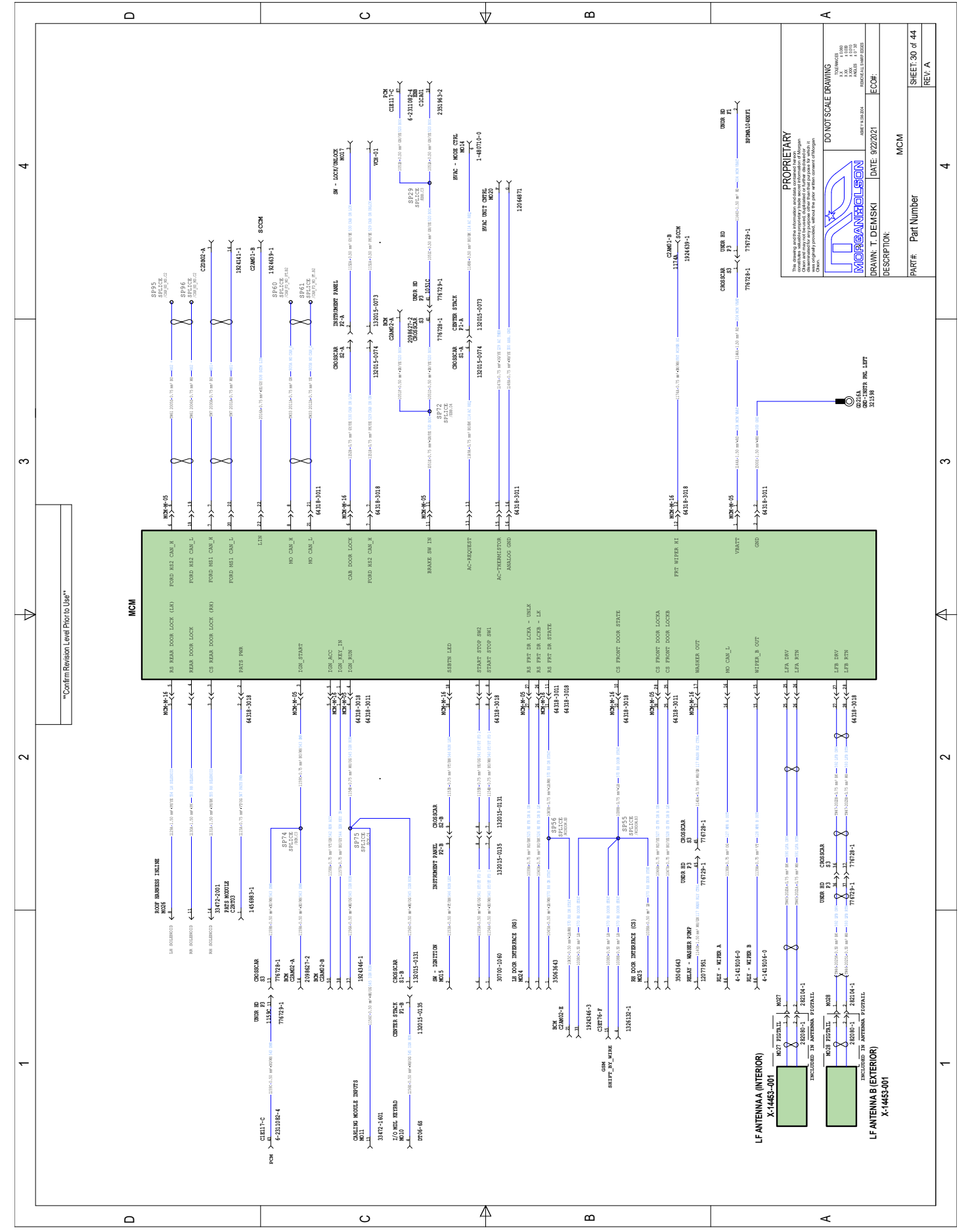
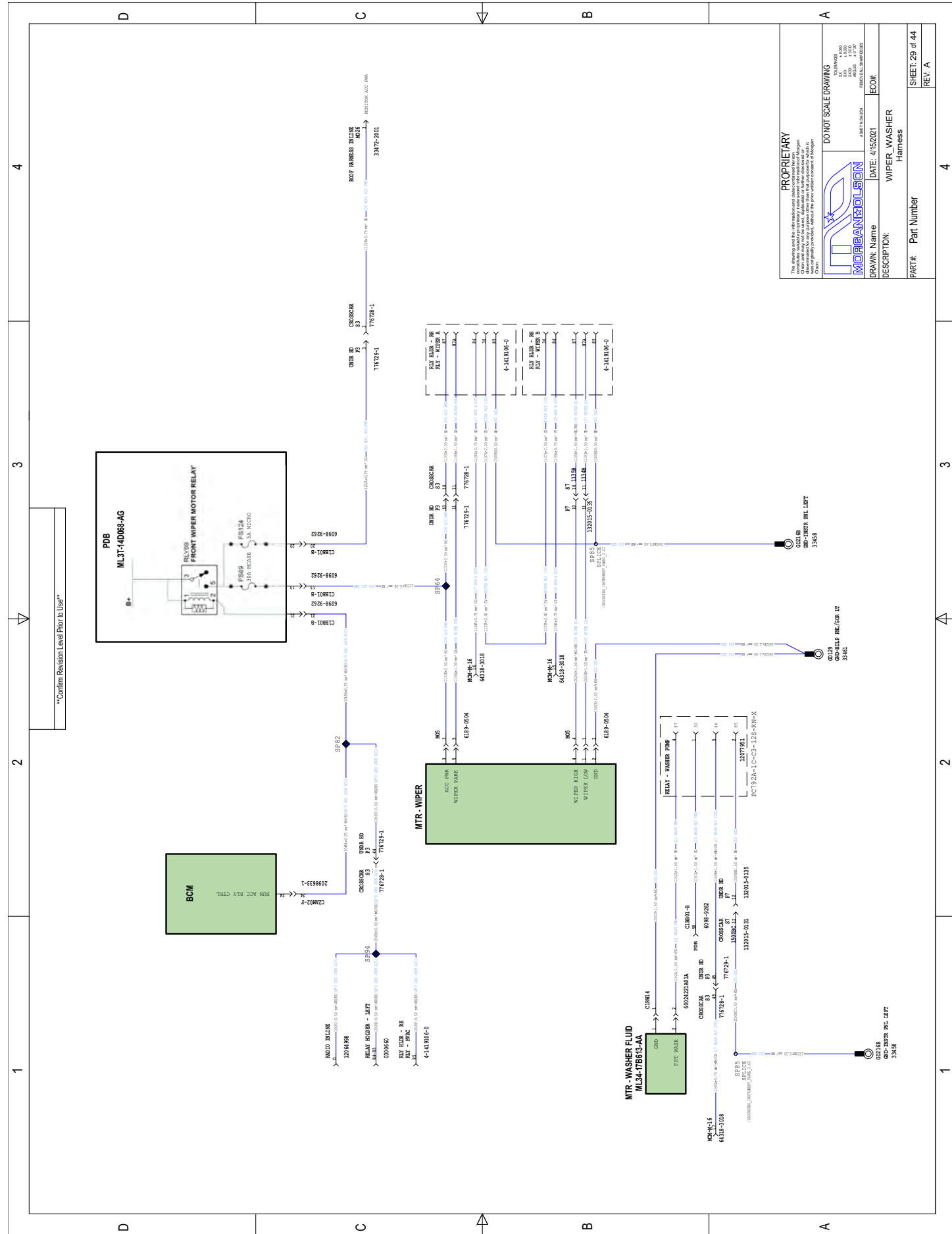

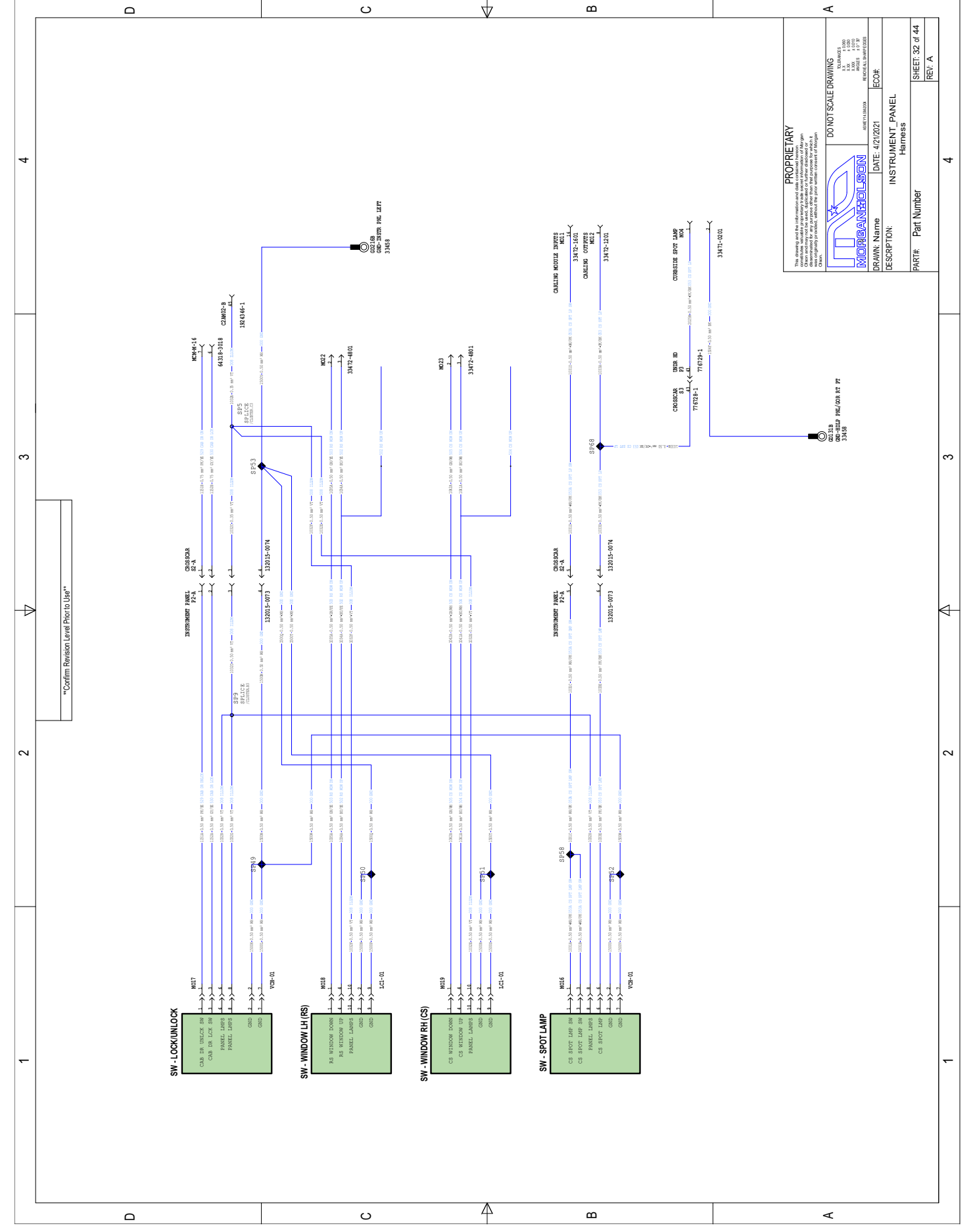
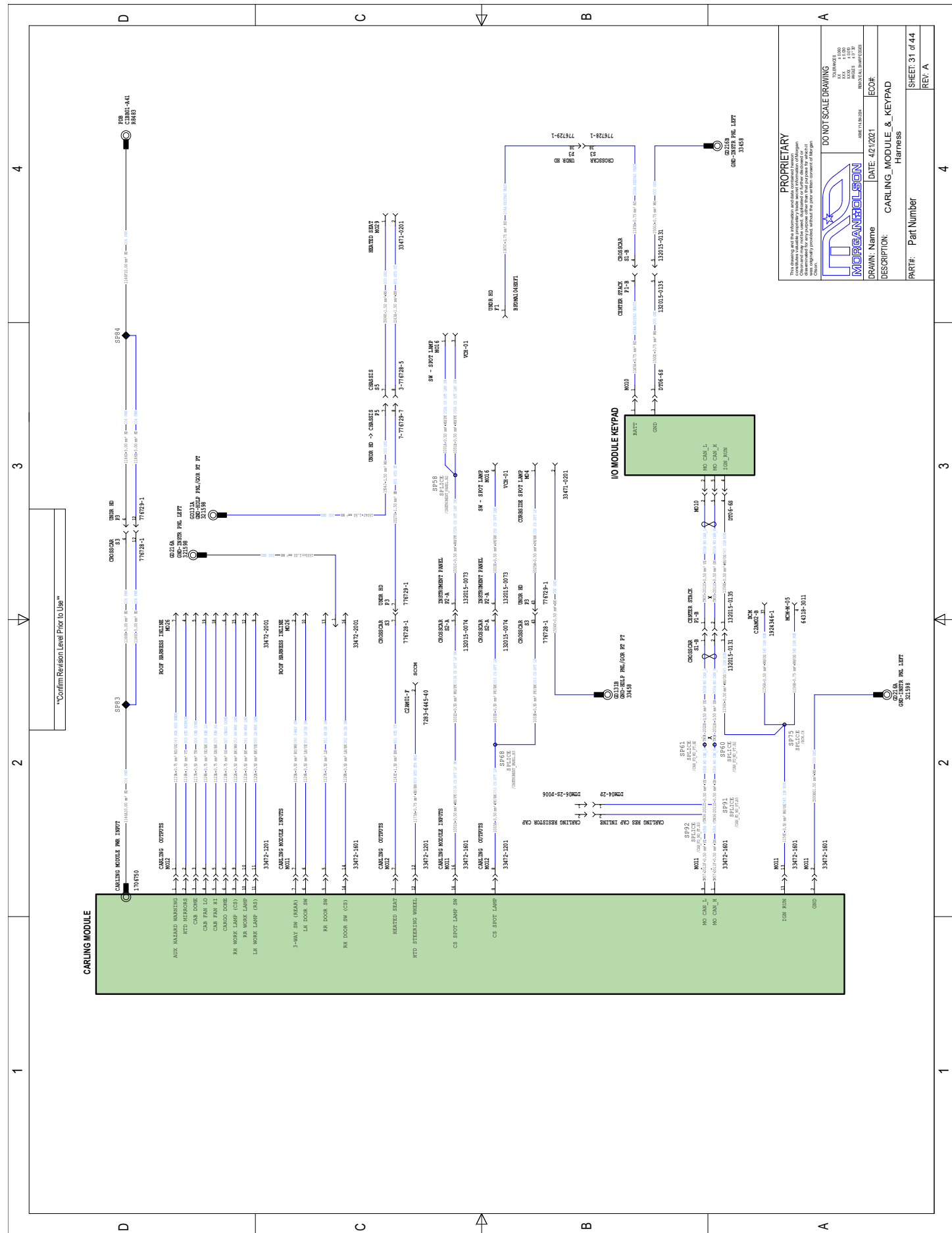

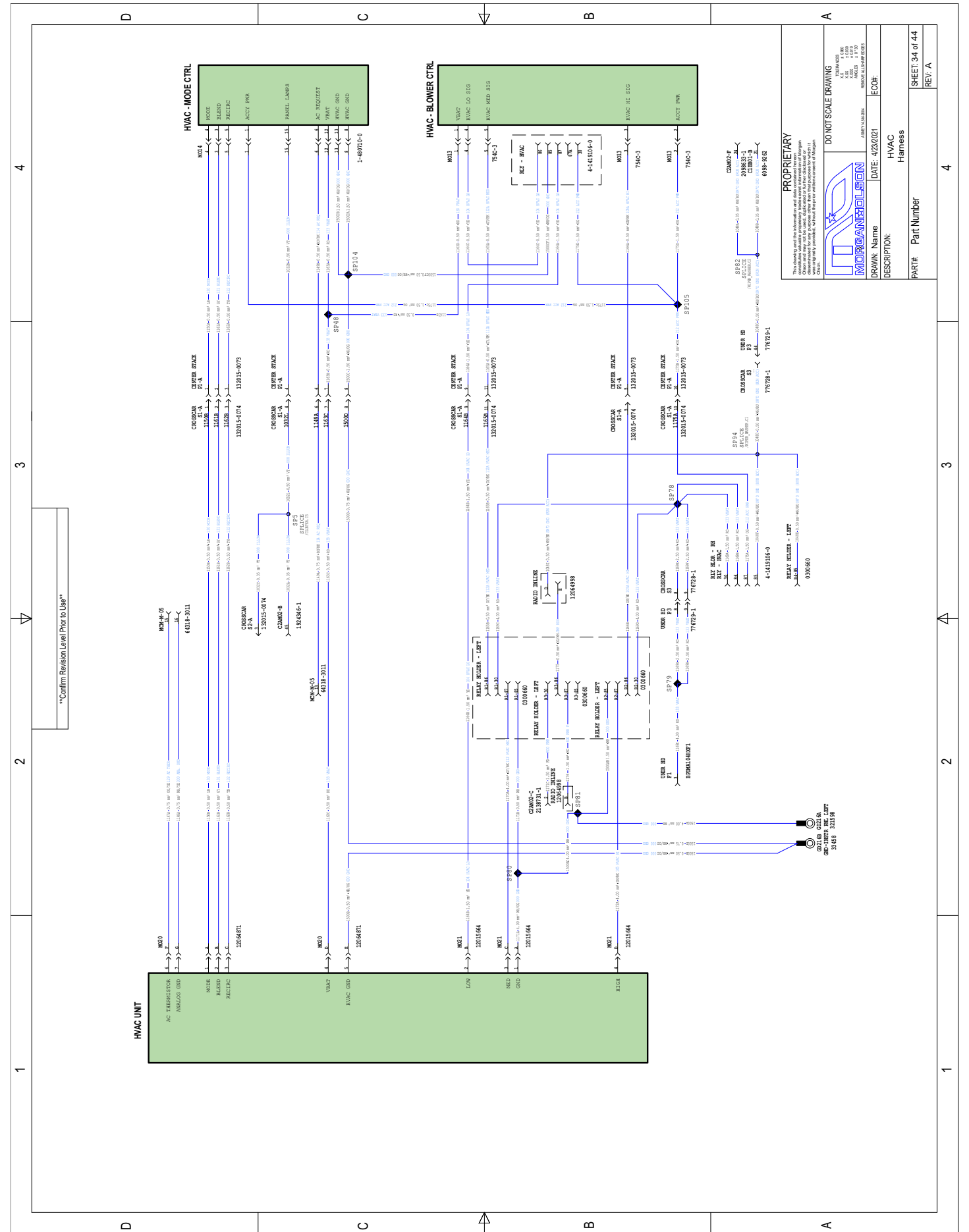
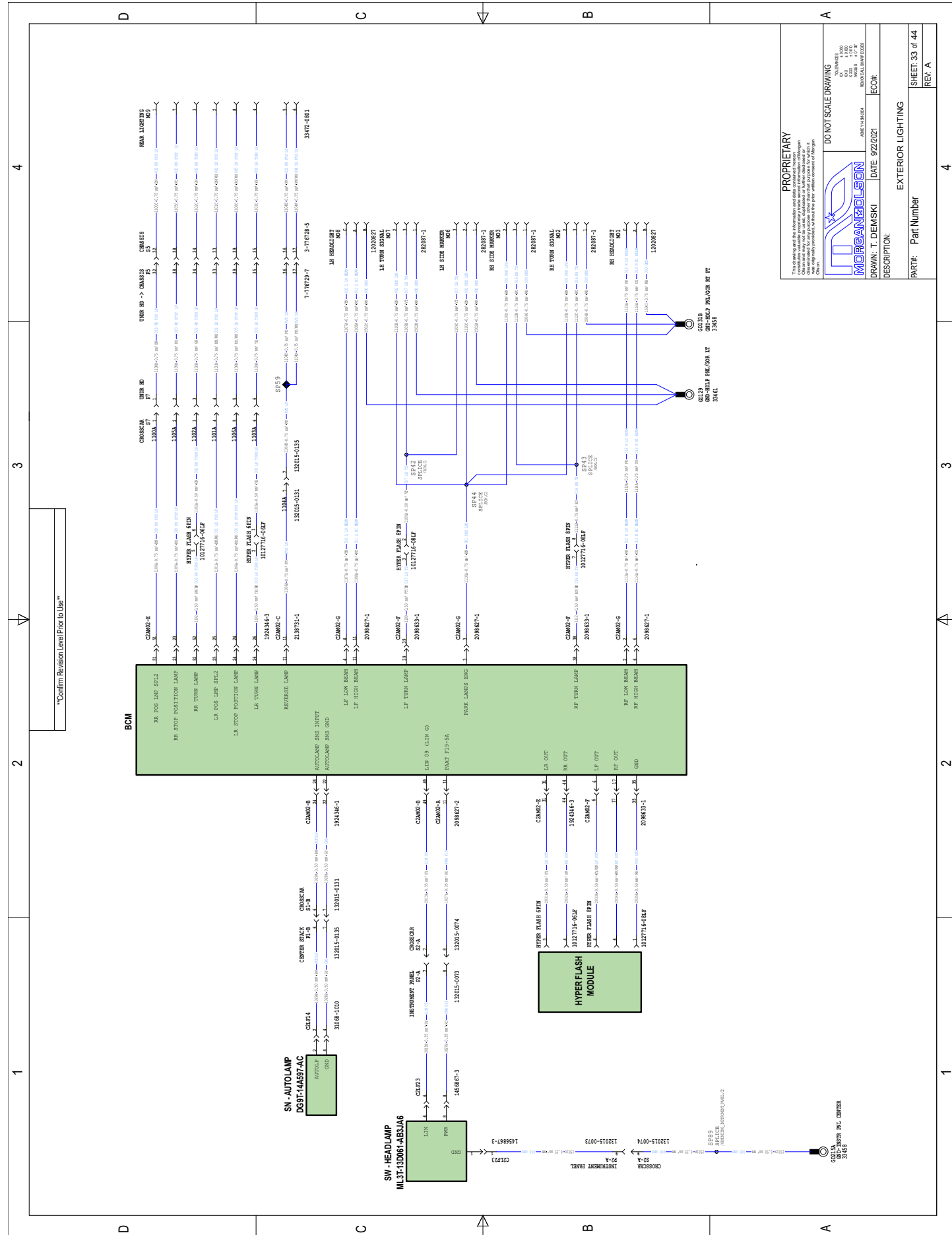

14 - Schematic Diagrams

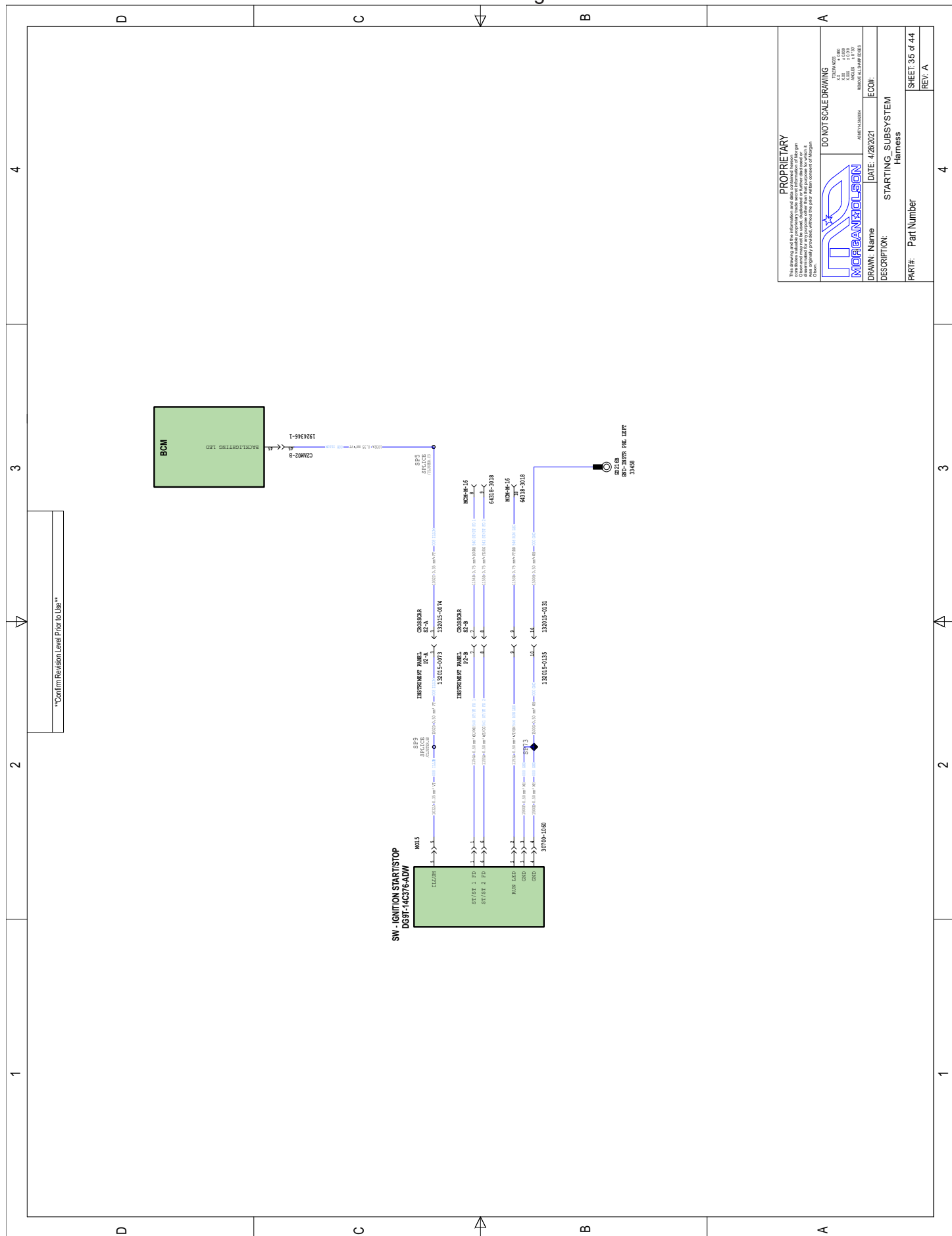

14 - Schematic Diagrams

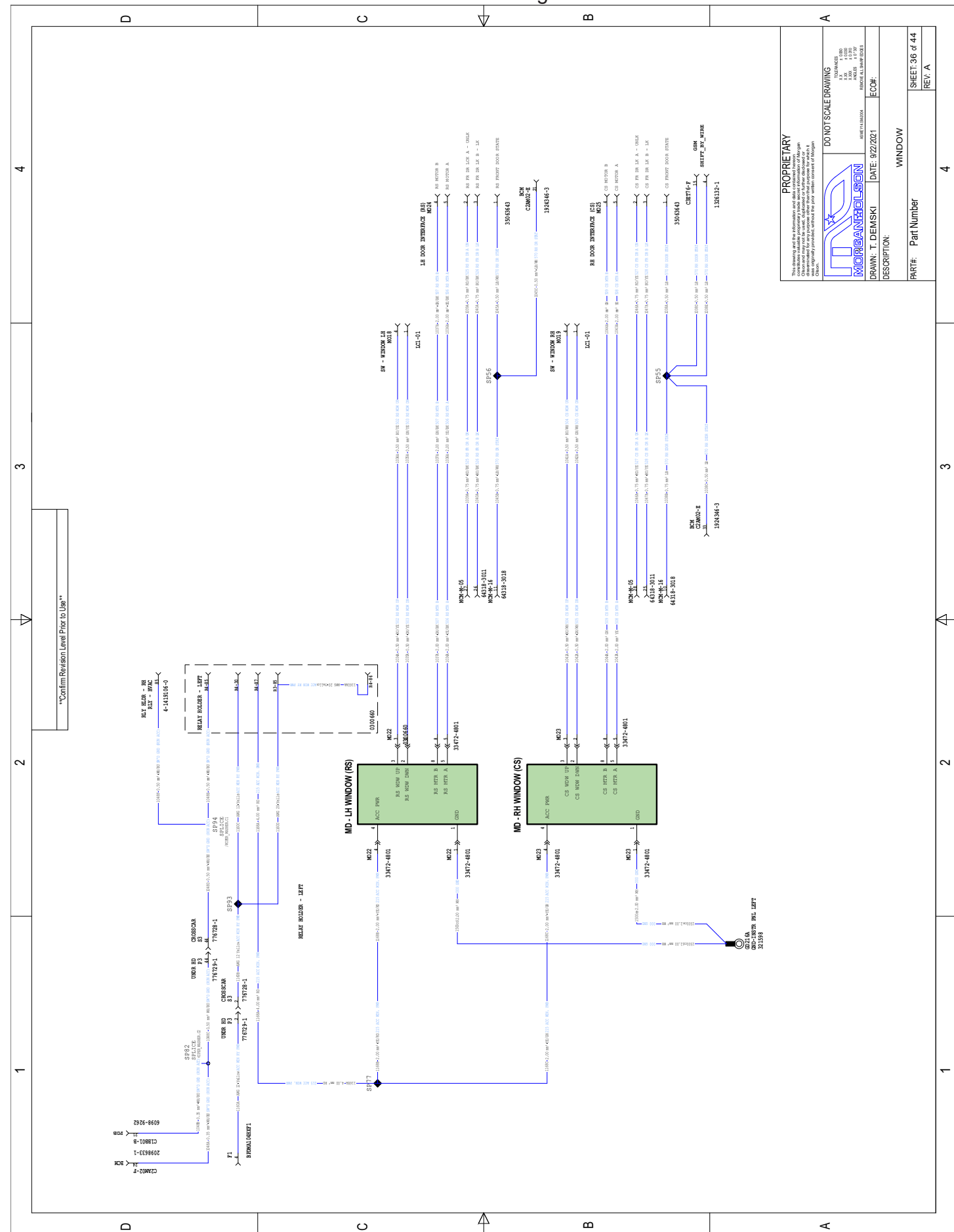

14 - Schematic Diagrams

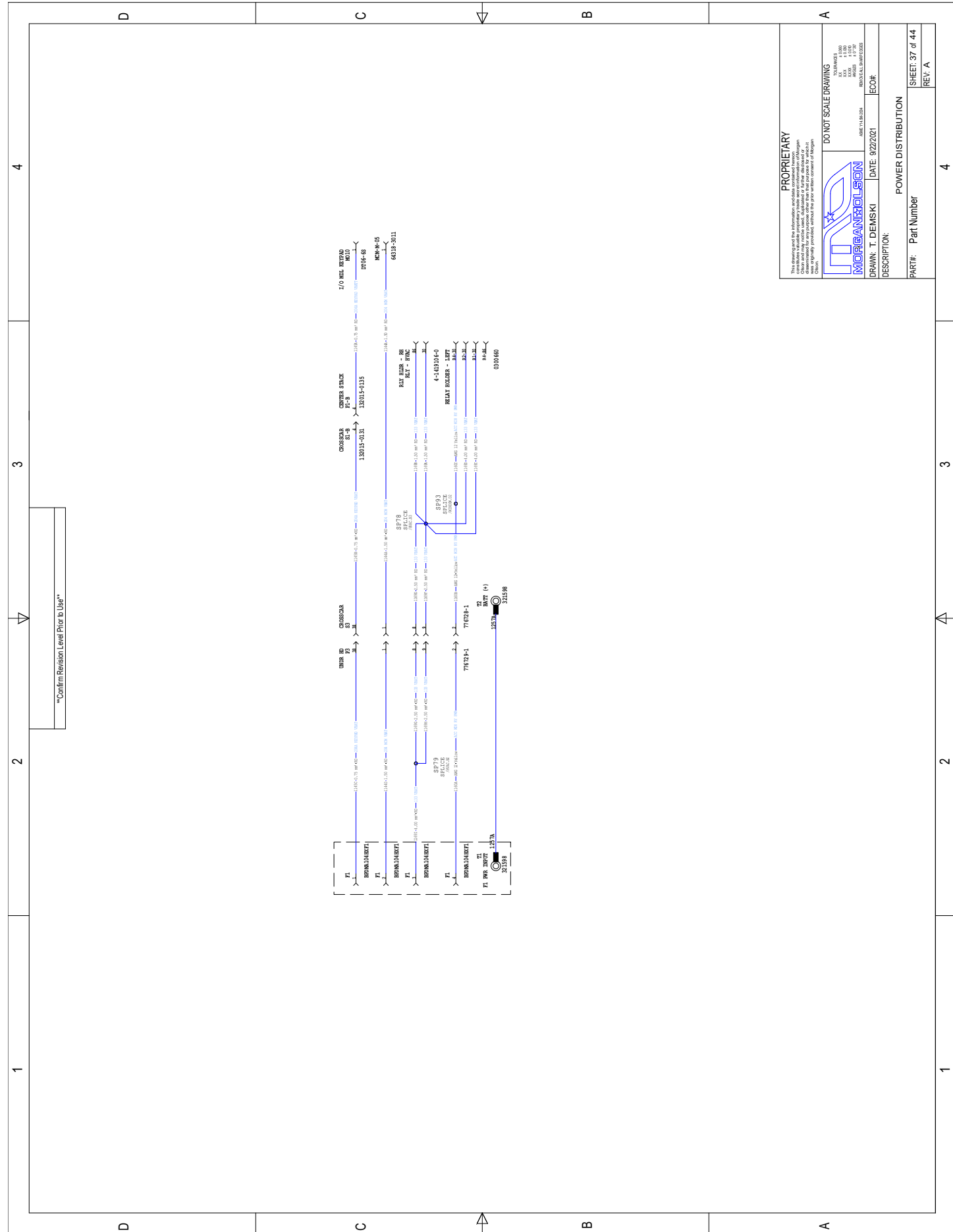

14 - Schematic Diagrams

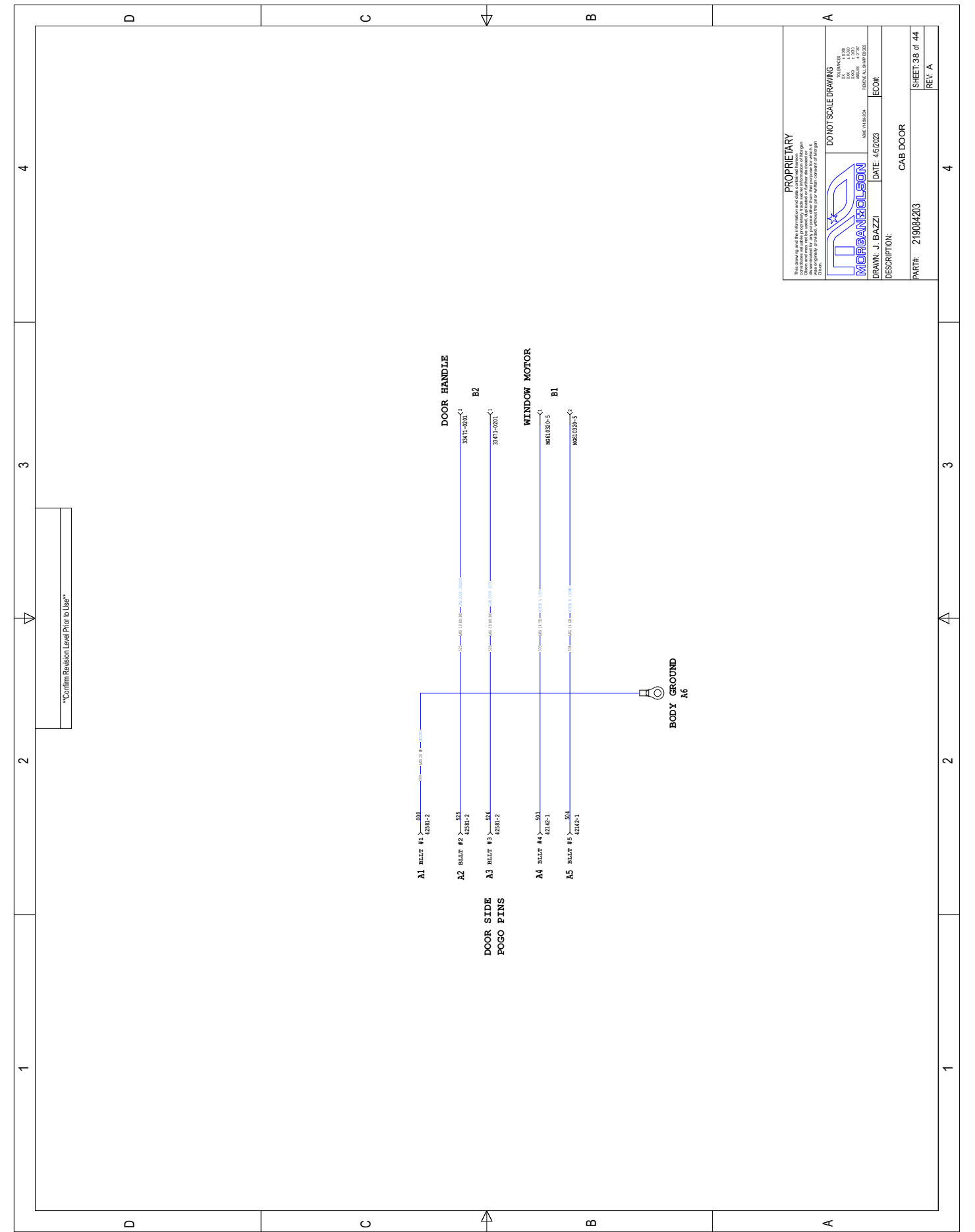

14 - Schematic Diagrams

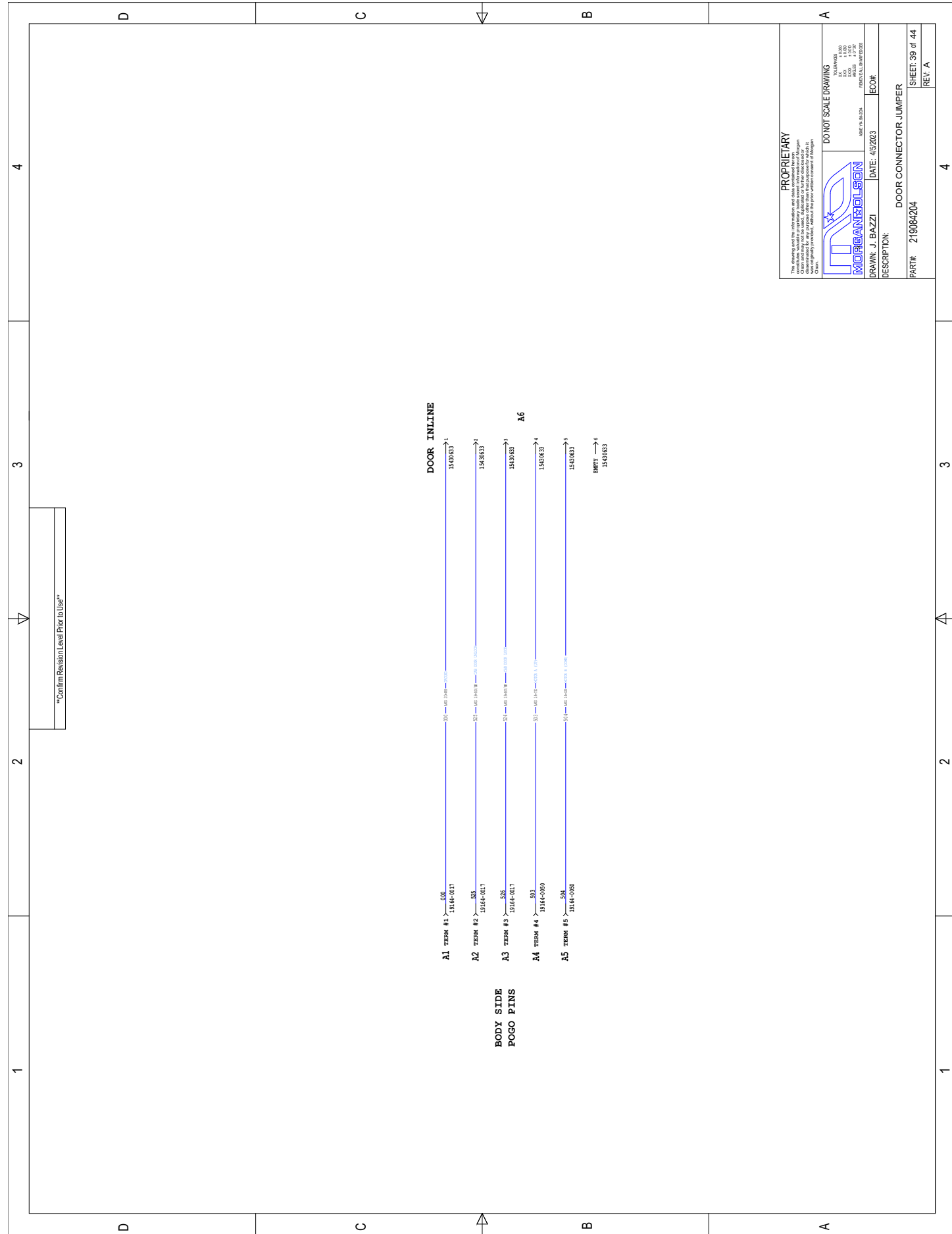

14 - Schematic Diagrams

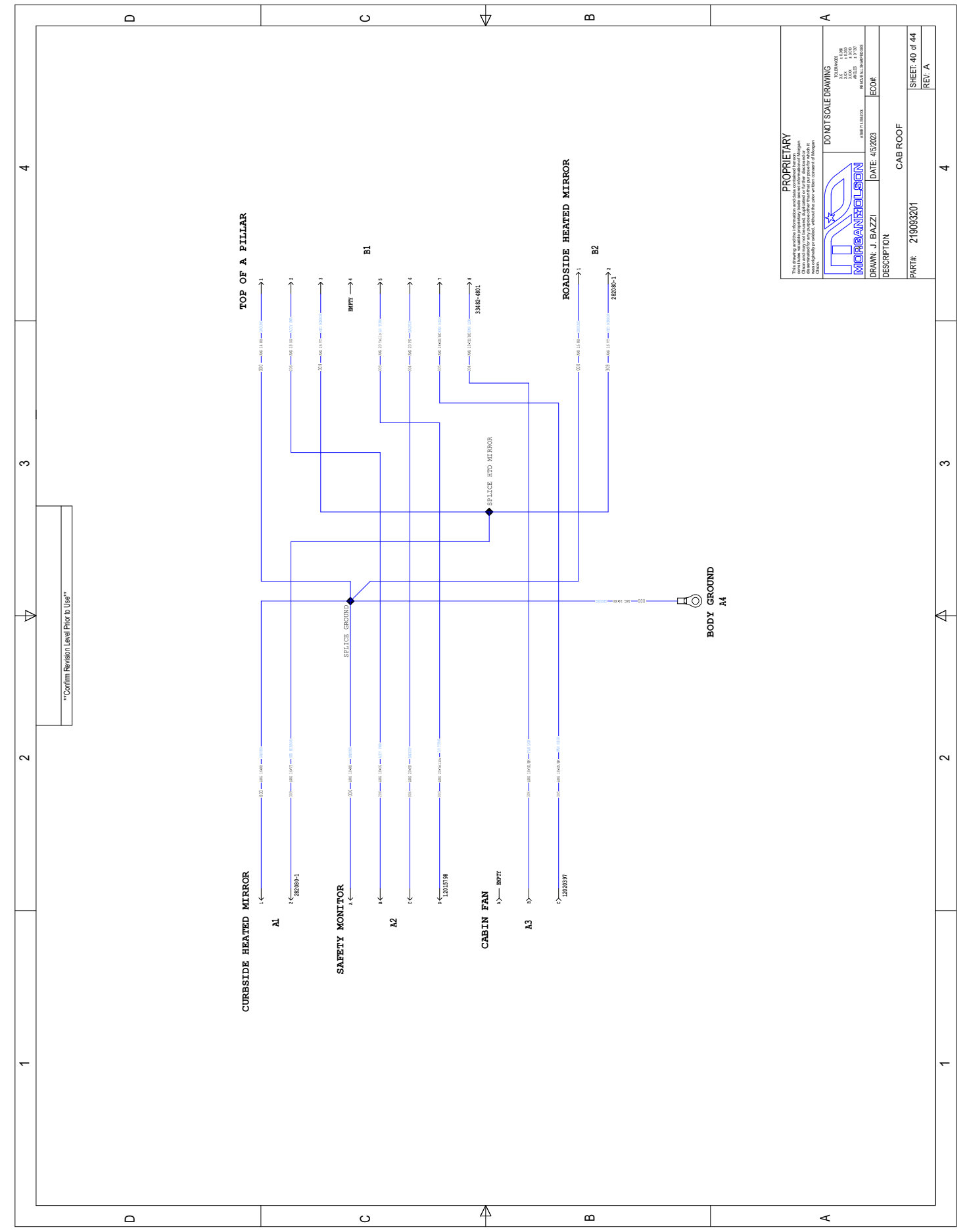

14 - Schematic Diagrams

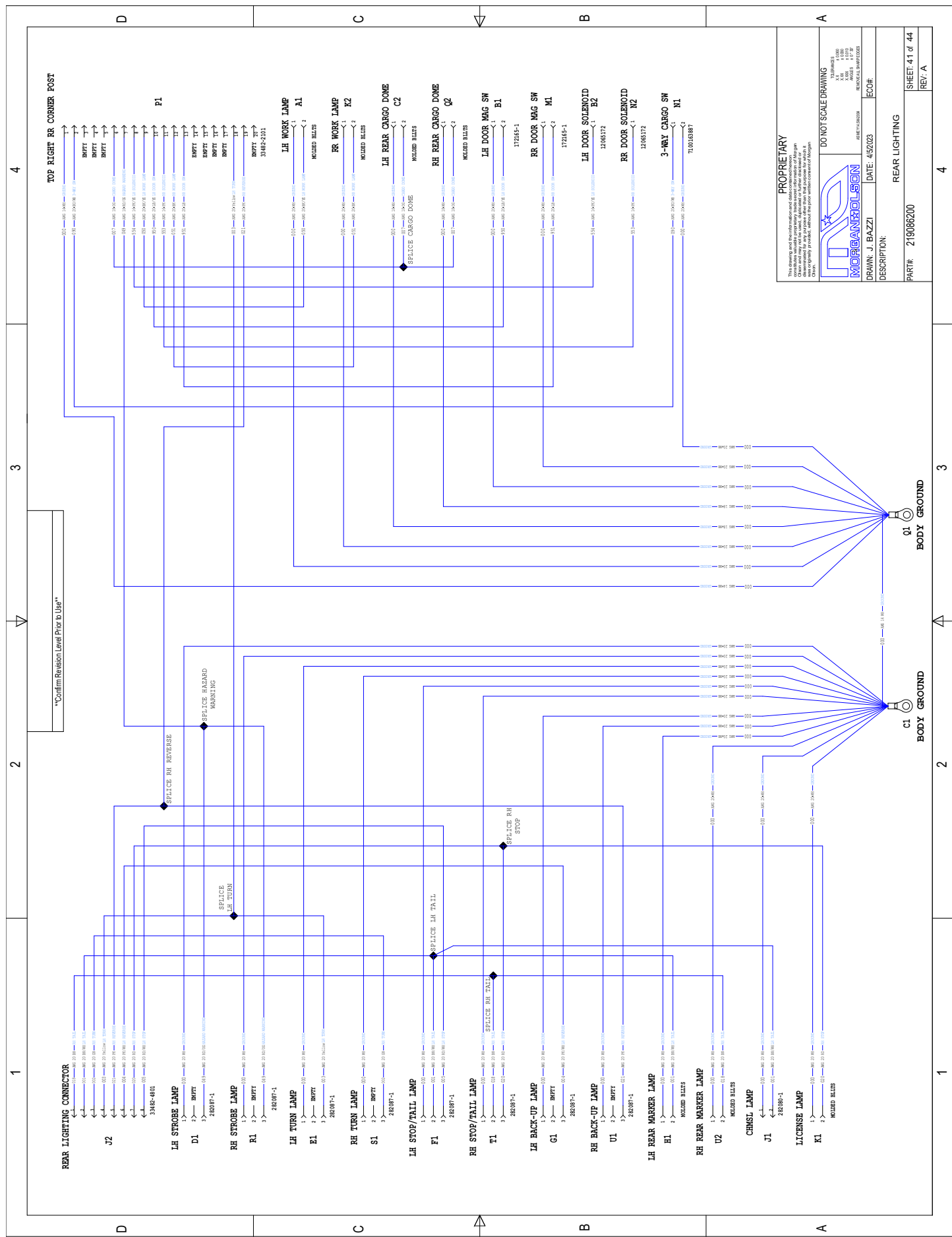

14 - Schematic Diagrams

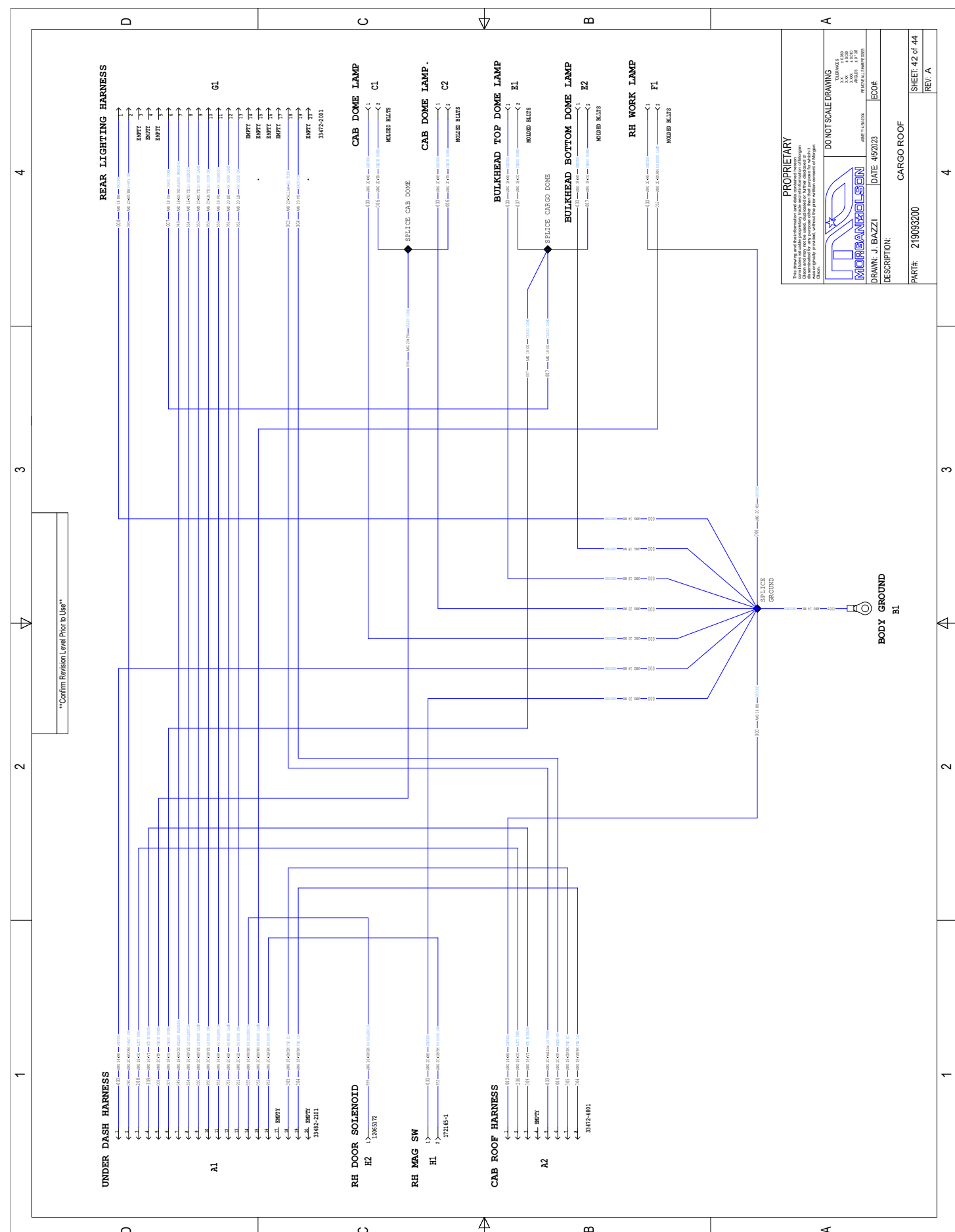

14 - Schematic Diagrams

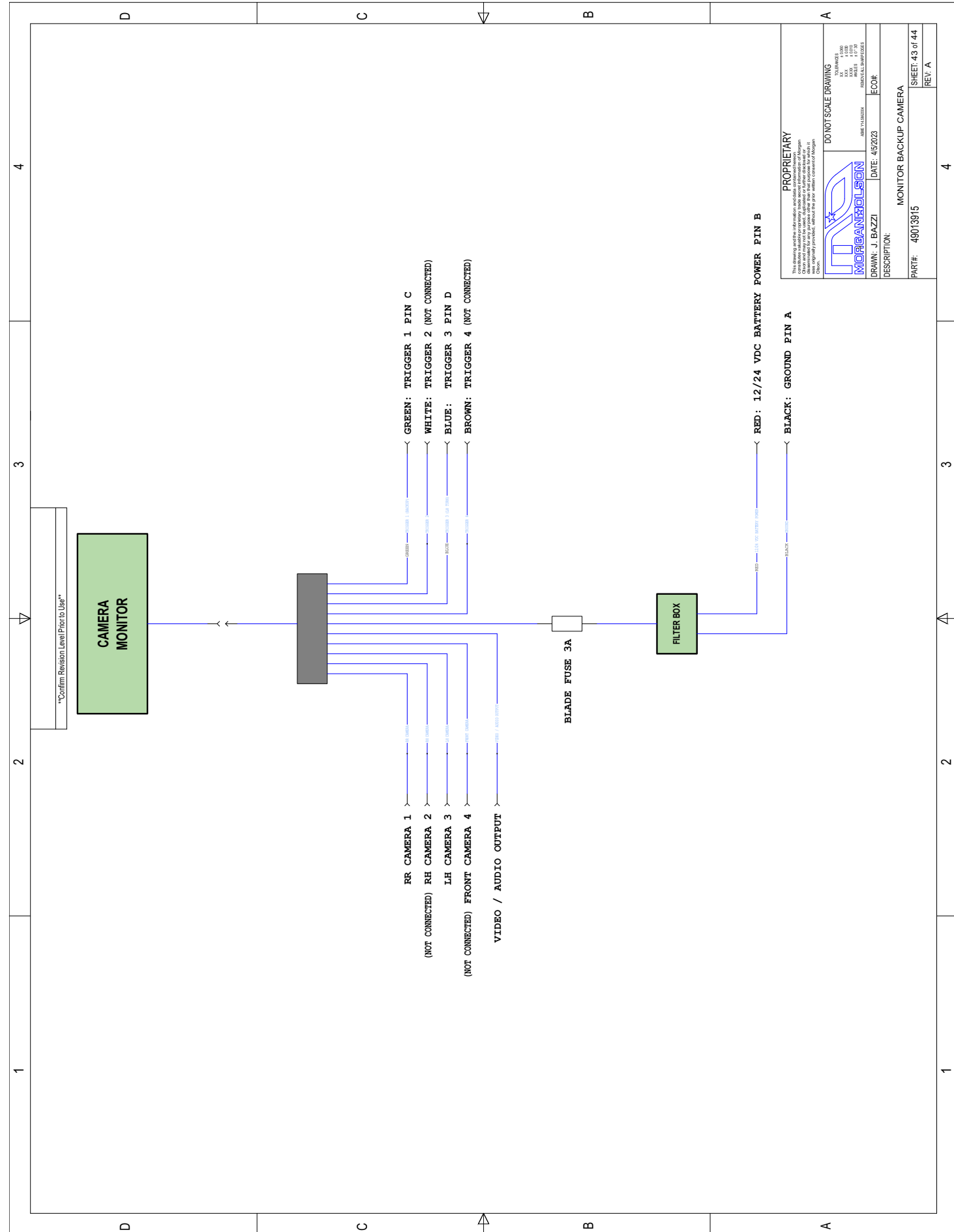

14 - Schematic Diagrams

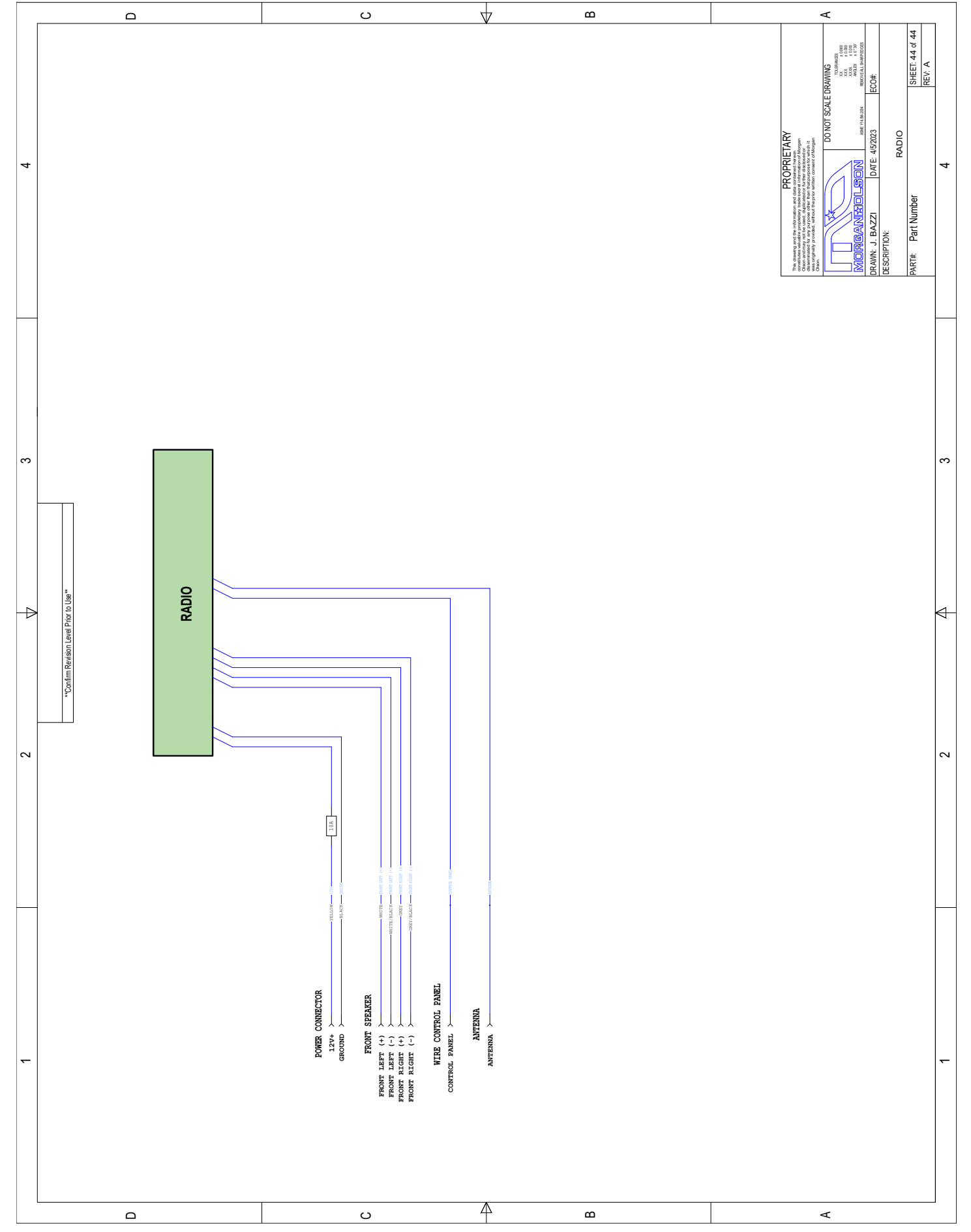

FORD Modules from F-150

PART #	DESCRIPTION	QTY	UM	FIRMWARE
CS9005001	HOOD RELEASE	1	EA	N/A
CS9007001	BODY MOUNTING	4	EA	N/A
CS9007002	TIRE 265-70R18	4	EA	N/A
CS9007004	HOUSING FUEL	1	EA	N/A
CS9007005	DOOR FUEL FILL	1	EA	N/A
CS9009001	BATTERY BOX	1	EA	N/A
CS9017001	HINGE HOOD LH	1	EA	N/A
CS9017002	HINGE HOOD RH	1	EA	N/A
CS9017003	GAS SPRING HOOD	2	EA	N/A
CS9017004	STRIKER HOOD	1	EA	N/A
CS9026001	SPLASH PAN F150 LH	1	EA	N/A
CS9026002	SPLASH PAN F150 RH	1	EA	N/A
CS9027001	HANDLE RELEASE TRANS	1	EA	N/A
CS9027002	STEERING SHAFT LOWER	1	EA	N/A
CS9027004	COVER VINYL STEERING COLUMN	1	EA	N/A
CS9027005	STEERING SHAFT BEARING ASM	1	EA	N/A
CS9027006	STEERING COLUMN	1	EA	N/A
CS9027010	PEDEL BRAKE ASM	1	EA	NO special flash
CS9027011	PEDEL GAS ASM	1	EA	NO special flash
CS9027012	BRK BOOS ASM	1	EA	NO special flash
CS9027013	SENSOR AMBNT LAMP DASH F150	1	EA	NO special flash
CS9027014	SWITCH HEADLAMP F150 2021	1	EA	NO special flash
CS9027015	LEVER PARK BRAKE F150	1	EA	NO special flash
CS9027016	POWER POINT USB 5V OUTPUT	1	EA	NO special flash
CS9027017	COVER POWER POINT USB	1	EA	N/A
CS9027018	SWITCH HAZARD W/TRAC CONT	1	EA	NO special flash
CS9027021	MODULE I/P CSTR F150	1	EA	YES special Flash
CS9027022	MODULE BCM RHD F150	1	EA	YES special Flash
CS9027023	MODULE RCM RHD F150	1	EA	YES special Flash
CS9027024	MODULE ECG F150	1	EA	YES special Flash
CS9027025	MODULE TCCM F150	1	EA	NO special Flash
CS9027026	MODULE PDB F150	1	EA	NO special Flash
CS9027027	ANT PATS IGN	1	EA	NO special flash
CS9027028	MODULE PCM F150	1	EA	YES special Flash
CS9027029	CLIP BCM RHD F150	1	EA	N/A
CS9080001	SHRD CHRGR AIR CLR	1	EA	N/A
?	MODULE ABS	1	EA	YES special Flash
49013134	MODULE SCCM	1	EA	YES special Flash
CS9008001	NUT STL HEX M12 PLT ADJ	2	EA	N/A
CS9012002	FUNNEL F/FIL	1	EA	N/A
CS9027003	COVER STEERING COLUMN	1	EA	N/A
CS9027019	SWITCH 4WHEEL DRIVE	1	EA	N/A

Blank